

TEST EQUIPMENT

EASTERN ELECTRONICS TEST EQUIPMENT

MAGNETO TIMING LIGHT - MODEL E50



Designed specifically for internal timing of aircraft magnetos and for synchronizing magnetos to aircraft engines. Eliminates all guesswork and provides a greater safety factor by creating perfect timing quickly and easily. Simply attach three clips to the magnetos and adjust until both bright lights flash in sync and the buzzer changes pitch. Fail-safe circuitry, variable pitch buzzer. Heavy-duty 3"x 5"x 2-1/8" unbreakable case. Wt. 1.5 lbs. Complete with 18 gauge lead wires 36" long and instructions. P/N 12-01013 **\$73.95**

U.S. Industrial EquivalentP/N TP105**\$57.50**



MAGNETO P-LEAD TEST ADAPTER

The P-Lead Adapter allows connection of magneto timer leads to Bendix aircraft magnetos with immediate and positive connection. Eliminates fooling with old P-leads that are stripped back and dangling. The unique design insures proper spring pressure against the internal contact, provides secure and stable alignment and has a post that prevents the timer leads from falling off. Sold in pairs. For Bendix S4 & S6.....P/N 07-05650..... **\$29.95 Pr**

AIRCRAFT TIMING INDICATOR MODEL E25



This all-aluminum unit improves and speeds up the timing of magnetos to the engine. Easily attached to propeller spinner, it is accurate to within 1/2 degree. Has easy to read dial and comes with top dead center locator and mounting bands. P/N 12-01014 **\$51.95**

Replacement Piston StopP/N 12-18100**\$15.50**

U.S. Industrial EquivalentP/N TP102.....**\$53.95**

MAGNETO TIMING LIGHT

These devices measure the change in inductance in the magneto coil when the points open and close. Simply shorting the clip leads together will not indicate a point closing, therefore eliminating any false reading caused by loss of contact to the magneto grounding terminal. To use, simply remove one plug from each cylinder. Connect black clip lead to engine ground. Connect red and green leads to right and left magneto terminals. Turn propeller slowly. When the points open the LEDs will turn off and the audio "tweeter" will sound. The magneto connected to the red lead will sound a rapid beat and the magneto connected to the green lead will sound a slower beat. When both sets of points are open, a third and continuous sound will be emitted. Adjust magneto timing accordingly. 100% solid state, compact 3/4" x 3" x 5" size, long battery life. Color coordinated leads are 4 ft. long. Comes in strong anodized aluminum case. Also available for single magnetos and without tweeter.

Dual Magneto Synchronizer w/TweeterP/N 12-16901**\$45.95**
 Dual Magneto Synchronizer w/o TweeterP/N 12-16902**\$34.30**
 Single Magneto Timing Light w/TweeterP/N 12-16903**\$36.90**

AIRCRAFT SPRUCE WEST
 CORONA, CA • (877) 4-SPRUCE

HIGH VOLTAGE CABLE TESTER MODEL E5



Gives a fast, accurate test of high voltage aircraft ignition cables. Simply connect 3 wires, push test button and test is completed. The E5 will instantly indicate in its test window both good and defective cables - no waiting for indication to appear. Fail-safe circuitry. Heavy-duty lead wires. Compact 3" x 5" x 2-5/8" case. Wt. 1-1/2 lbs. P/N 12-01016 **\$73.95**

U.S. Industrial equiv P/N TP103**\$58.50**

DIFFERENTIAL CYLINDER PRESSURE TESTER MODEL E2A



The Model E2A tester quickly locates worn or cracked rings, a defective intake or exhaust valve, scored or cracked cylinders, leaky head gaskets, worn or stripped spark plug bushings, etc. Eliminates guesswork by allowing you to locate the exact location and cause of your engine's loss of efficiency. The Model E-2M differential cylinder pressure tester, with a SLOW

FILL safety valve and built in Master Orifice, has been field tester for 2 years by Teledyne Continental Motors, and has been approved for use on Teledyne Continental Engines by their Engineering and Field Services Group. The new valving adds additional safety; speeds up the test process. Rugged construction features heavy-duty gauges, extra long high-pressure hose, precision regulator, all connections quick-disconnect, 18mm plug adapter. Complete instructions with each unit. "M" models have built-in master orifice.

E2A - for cylinders < 5" bore	P/N 12-01012.....	\$63.95
E2A-1000 - for cyl. > 5" bore	P/N 12-01017	\$63.95
E2M - for cylinders < 5" bore	P/N 12-01015	\$93.95
E2M-1000 - for cyl. > 5" bore	P/N 12-00692	\$99.95
E2A-12mm (Rotax) for cyl. < 5" bore.....	P/N 12-00693	\$66.50
12 mm Adapter.....	P/N 12-01018	\$14.95
10/14 mm Adapter	P/N 12-18201	\$11.50
18 mm Adapter.....	P/N 12-18202	\$12.50
U.S. Industrial Equivalent.....	P/N TP104.....	\$51.75
14MM Adapter	P/N TP171.....	\$13.10
18MM Adapter	P/N TP104-9A.....	\$14.40



COMPRESSION TESTER EXTENSION

This tool makes compression testing easy. Wrench free way to test that allows for exhaust system and baffling clearance. Tester is manufactured with quality-welded construction and offers a spark plug thread with O-Ring seal. It has a standard air fitting. P/N 12-01060.....**\$29.90**

ALTERNATOR RIPPLE TESTER



The Model Aircraft Alternator Analyzer and voltage Regulator Tester can help you detect alternator and/or voltage regulator problems before a total systems breakdown and thus prevent in flight electrical failures. Just clamp on the inductive probe, 2 clip leads, then run the engine. Completely portable and self contained, no batteries or electrical connections. Provides Oscilloscope performance with easy to use "go" or "no go" meter. No alternator wires are disconnected, and complete test takes only 5 minutes. Checks for open or shorted diodes, stators, field circuits, and defective voltage regulators. Comes complete with meter, leads, clips, carrying case, & instructions. Wt. 3 lbs. Model 648 Tester P/N 12-12810.....**\$656.00**



AUDIOTECH PROBE

The Model AT100 diagnostic Listening Tool is a versatile, time-saving tool which is ideal for use in any application where there is movement of mechanical parts, air, gas, or fluid. Ideal for use on commercial, general aviation, or homebuilt aircraft and helicopters for application such as air leak and vacuum detection, bearing wear, worn or chipped gears, engines, turbines, and compressors, hydraulics, fuel injectors, flow valves, instrument failure, and more. Audiotech Probe can quickly and accurately pinpoint the trouble spot so that the problem can be fixed quickly the first time. Diameter of small mic at end of probe is 3mm. Vinyl storage case & AAA battery included. Perfect for homebuilders, A & P's, A & E's, and A & I's. P/N 12-21420**\$18.50**

TO

AIRCRAFT SPRUCE EAST
 PEACHTREE CITY, GA • (877) 477-7823

PENETRANT INSPECTION KITS—MALLETS—HAMMERS

MAGNAFLUX NDT (NON-DESTRUCTIVE TESTING) KIT

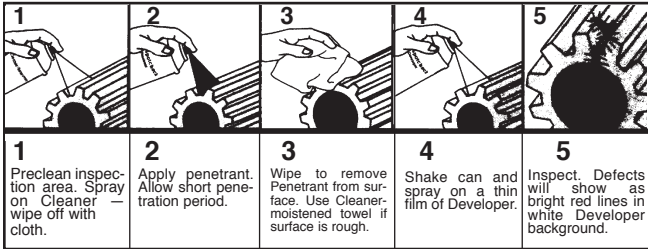

A quick, easy way to make shop and in-field inspections of landing gear, airframe and components. Highly sensitive Spotcheck dye penetrants which give clear, bright red indications. Locates very fine cracks on the surface of ferrous and non-ferrous components, equipment and structures. Reveals cracks on materials with surface temperatures as high as 350°F. Perfect for testing welds before thorough cooling. Convenient spray cans make application easy and contain no fluorocarbon propellants. Non-flammable. Materials meet applicable specifications for dye penetrant inspections (ASME, ASTM and MIL specs). Considered flammable and hazardous by UPS.



4-CAN SPOT CHECK® TEST KIT - The lowest priced way to check for cracks, leaks and other defects on any metal parts. Kit includes 1 spray can of developer, 2 cans of cleaner & 1 can of dye penetrant in cardboard case.
 Magnaflux 4-can kit ..P/N 09-00391.....\$59.85
 Developer.....P/N SKD-S2\$11.85
 Replacement Materials: Penetrant.....P/N SKL-SP\$13.80
 Cleaner/Remover (12oz. Aerosols)P/N SKC-S\$11.20

SK-3 KIT - The SK-3 kit is larger, comes in a lightweight high-impact plastic carrying case containing 2 cans of penetrant SKL-SP, 4 cans of cleaner/remover SKC-NF, 2 cans of developer SKD-NF, brush, cloth and instructions. P/N SK-S\$105.95

SKC-S Cleaner: This clear, fast-drying solvent can be used for pre-cleaning, post-cleaning and penetrant removal. P/N SKC-S\$11.20

SKL-SP Penetrant: Because of its vivid red color, this solvent removable dye penetrant provides excellent color contrast performance to locate surface cracks in virtually any metal or non-porous ceramic material. P/N SKL-SP\$13.80

SKD-S2 Developer: Made especially for use with SKL-SP penetrant, this developer contains suspended white particles that provide an ideal background for red Spotcheck penetrant indications. P/N SKD-S2\$11.85

MET-L-CHEK PENETRANT INSPECTION KITS



Met-L-Chek kits provide a completely portable, job-proven method used throughout the industry to locate cracks, flaws and other defects. These economical & effective kits provide everything needed to make inspections in the shop or field. The penetrant materials are packaged in easy-to-use aerosol spray cans and a can of cleaner included for cleaning parts before inspection. The inspection procedure is easy to learn, accurate and inexpensive. Met-L-Chek can be used on ferrous and non-ferrous materials to find surface defects and 'thru leaks'. Supplied in a rugged metal case with complete instructions. The 4-Can Kit has one aerosol spray of cleaner, penetrant, developer and remover. The 8-Can Kit has 2 cans of each material. Individual replacement cans available. 4-Can Kit.....P/N 09-38304.....\$46.60
 8-Can Kit.....P/N 09-38308.....\$79.25

IMPERIAL 470-FH TRIPLE HEAD 180° TUBING BENDER

The 470-FH Triple Head 180° Tube Bender bends 4 diameters of tubing with just one tool! It handles soft copper, aluminum and thin-walled steel tubing in 3/16", 1/4", 5/16" & 3/8" diameters. Like the heavy duty 464-FH, it features the patented ROTO-LOK™ two-stage handle that allows east fabrication of bends up to 180°. It also features optimized bending grooves that allow the user to bend the tubing in the smallest radius possible to enable tighter turns and minimize the space taken by the bends. P/N 12-01042\$27.60

AIRCRAFT SPRUCE WEST
 CORONA, CA • (877) 4-SPRUCE

GARLAND NON-MARRING MALLETS AND HAMMERS



Since 1866, Garland Manufacturing has been supplying America with top-quality products made from the finest water buffalo rawhide. Today, they're the leader in the manufacture of soft-faced mallets and hammers of unsurpassed quality.

All Garland products are manufactured in the U.S.A. to ISO 9002 international quality standards. They combine superior craftsmanship with the best materials and then field-test their products extensively on a range

of surface finishes to meet the requirements of the industries in which they're used. Industries ranging from foundries and electrical manufacturing to jewelry and woodworking. Their mallets and soft-faced hammers are preferred by both craftsmen and production workers.

RAWHIDE AND WEIGHTED RAWHIDE MALLETS

Garland's all-rawhide mallets are made of tough, long-wearing, water buffalo rawhide. They're ideal for use on broad-faced striking surfaces in a broad range of applications.

Rawhide Mallets					
Size	Face Dia. (Inches)	Head Length (Inches)	Weight (oz.)	Part No.	Price
0	1"	2"	2	12-00749	\$12.90
2	1-1/2"	3"	6	12-00750	\$16.95
4	2"	3-1/2"	11	12-00751	\$25.30
6	2-3/4"	4-3/4"	24	12-00752	\$46.30
Weighted Rawhide Mallets					
Size	Face Dia. (Inches)	Head Length (Inches)	Weight (oz.)	Part No.	Price
7	1-1/4"	2-1/2"	8	12-00753	\$22.90
10	2"	3-1/2"	20	12-00754	\$31.60

RUBBER MALLETS

Garland's rubber mallets are designed for general-purpose applications. All sizes deliver solid, mar-free blows.

Size	Face Dia. (Inches)	Head Length (Inches)	Weight (oz.)	Part No.	Price
1	2-1/4"	3"	17	12-00755	\$22.90
2	2-1/4"	3-7/8"	19	12-00756	\$23.60
3	2-1/2"	4-1/2"	32	12-00757	\$27.50

SPLIT-HEAD HAMMER



The split-head hammer does the work of six different hammers because the face can be easily changed. Available in two sizes.

• Many materials & surfaces • Foundry • Die moving or positioning • Assembly • Electric Motor Repair • Propeller Repair

Size	Face Dia.	Head Length	Weight	Part No.	Price
3	1-3/4"	4-3/4"	2.5 lbs	12-00965	\$31.60
5	2-3/4"	5-3/4"	5.25 lbs	12-00966	\$39.60

IMPERIAL 464-FH 180° TUBING BENDER

The 464-FH Heavy Duty 180° Tube Bender line consists of 3 benders for 1/4", 3/8", & 1/2" stainless steel and other tough tubing metals! Its patented ROTO-LOK™ quick action trigger release two-stage handle allows the tubing to be bent up to 180° without crossing the hands or handles! This means bends are made with reduced effort and much better control. 1/4" benderP/N 12-01043\$54.00
 3/8" benderP/N 12-01044\$76.95
 1/2" benderP/N 12-01045\$224.99

AIRCRAFT SPRUCE EAST
 PEACHTREE CITY, GA • (877) 477-7823

TO

TUBE BENDERS – CUTTERS – FLARING TOOLS



SPRING TUBE BENDERS

Economical tools for hand-bending of soft aluminum and copper tubing to any shape without collapsing walls. Special spring steel, nickel finished. End belled for quick tube removal. Set of 6 for 1/4", 5/16", 3/8", 7/16", 1/2" and 5/8" O.D. tubing. P/N 101-F\$12.80

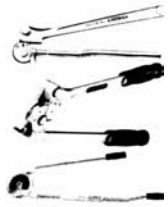

LEVER TYPE BENDERS

Each tool bends one size. Open side type slips over tube at any point. Makes smooth short-radius bends up to 180° with minimum effort. No marking, scraping or flattening of tubing. Calibrated to show angle of bend. Wide hook grips tube securely. Suitable for bending annealed copper, aluminum, steel, stainless steel and hard copper tubing of bending temper.

Tubing O. D.	Bender Model No.	Part No.	Bending Radius	Price
1/8"	364-FH-02	12-20002	3/8"	\$46.20
3/16"	364-FH-03	12-20003	7/16"	\$78.75
1/4"	364-FHA-04	12-20004	9/16"	\$78.25
5/16"	364-FHA-05	12-20005	11/16"	\$94.50
3/8"	364-FHA-06	12-20006	15/16"	\$79.75
1/2"	364-FHA-08	12-20008	1-1/2"	\$121.95
5/8"	364-FHA-10	12-20010	2-1/4"	\$216.95
3/4"	364-FHA-12	12-20012	3"	\$293.95

WIDE RANGE LEVER TYPE BENDERS

Tool quickly adapts to all sizes in its range by changing forming wheel and block. Long handles re-position during bend for best leverage. Calibrations show precise bend angle. Benders for 3/8" through 3/4" O.D. tubes are as illustrated. Benders for 1/4" and 5/16" O.D. tube in #350-FHA kit are one piece type. Kits furnished in steel tool box.

Model 350-FHA Kit- For 1/4", 5/16", 3/8", 1/2", 5/8" & 3/4" TubeP/N 12-20100\$745.00
 Model 360-FHA Kit- For 3/8", 1/2", 5/8" & 3/4" TubeP/N 12-20200\$575.00



TRIPLE HEADER TUBE BENDER

For bending annealed copper, aluminum, brass, steel and stainless steel tubing. Multi-tube design does the work of three conventional lever type benders. Calibrated markings for making accurate left-hand, right-hand and offset bends.

P/N 367-FH (for 1/8", 3/16", 1/4" O.D.).....\$19.80

IMP® TRIPLE HEADER TUBE BENDER

Calibrated markings for making accurate left-handed, right-handed and offset bends. 90° start requires less effort-making bending fast and easy. For 1/4", 5/16", & 3/8" (6 & 8 mm) O.D. tubing. 15/16" radius to center of tube. P/N 368-FH (for 1/4", 5/16", 3/8" OD) \$41.60



SOFT PIPE/TUBING CUTTER

This economical tool will cut soft pipe and tubing up to 1-1/4" outside diameter. The blade is teflon-coated and reverses for double the useful life of the blades. P/N 12-20020\$10.95 ea.

Replacement BladesP/N 12-20025\$5.85 ea.



EZ-BEADER TUBING BEADERS

Designed to replace the original Parker beading tools. Compact design. Capable of tubing wall thickness from .035 to .065 thick

Model No.	Part No.	Price
TP885A (3/8" tube O.D.)	12-00354	\$47.85
TP885B (1/2" tube O.D.)	12-00355	\$51.00
TP885C (5/8" tube O.D.)	12-00356	\$58.25
TP885D (3/4" tube O.D.)	12-00357	\$66.25
TP885F (1" tube O.D.)	12-00358	\$76.50
TP885G (1-1/4" tube O.D.)	12-00359	\$86.50
TP885H (1-1/2" tube O.D.)	12-00360	\$96.00
TP885I (1-3/4" tube O.D.)	12-00361	\$101.95
TP885J (2" tube O.D.)	12-00362	\$108.95
10 pc. kit all sizes (TP885A-TP885J) in storage pouch	12-00363	\$628.00



HI-DUTY TUBE CUTTER

For 1/8" to 1" O.D. metal tubing. Makes clean, right-angle cuts with no burrs or chips to clog tubing. Roller type with flare cut-off groove, fold-away reamer and spare cutting wheel. Wt. 6-1/2 oz.

Hi-Duty Tube CutterP/N TC1000\$31.80
 Replacement Cutter Wheel.....P/N 75015\$8.90
 Replacement Reamer BladeP/N 79318-01\$10.10

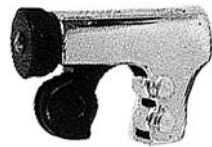

"IMP" TUBE CUTTER

Designed for use in tight quarters where other cutters won't fit. For 1/8" to 5/8" O.D. tubing. Requires only 1 3/16" swing radius. Perfect for instrument panels, control cabinets, machine tools, etc. Size: 1 11/16" x 1-5/16" x 7/8". Wt. 2-1/2 oz.

P/N TC-1050\$20.65



JUNIOR TUBE CUTTER

Exceptionally handy in close quarters - only 3-1/2" overall length. Makes clean, right-angle cuts without flattening tube. Cuts 1/8" to 3/4" O.D. tubing. Enclosed feed mechanism. Wt. 5 oz.

Junior Cutter.....P/N 227-FA.....\$18.85
 Replacement Cutter Wheel.....P/N 32633\$8.80

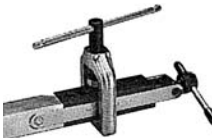

WEATHERHEAD T-1295 Heavy Duty Segmented Flaring Tool (37°)

Tool Flares: 1/8", 3/16", 1/4", 5/16", 3/8", and 1/2", O.D. tubing. Forms 37° flares in annealed stainless steel (MIL-T-6845 or AMS-5566), cold drawn stainless steel, and annealed copper, brass, steel or aluminum. Bar has vice extension. Wt.: 3lbs. P/N T-1295.....\$464.95



HI-DUTY FLARING TOOL 37°

Hard chrome-finished cone makes exceptionally smooth, high strength flares with a radius at base of flare instead of the sharp angle formed by ordinary tools. Slip-on yoke permits use in tight quarters. For tubing sizes: 3/16", 1/4", 5/16", 3/8", 1/2" and 5/8" O.D. Wt. 1 lb. 11 oz. Not for use on Stainless Steel Tubing. P/N 437-FB\$101.95



ROL-AIR FLARING TOOL 37°

Faceted, hard chrome finished cone rolls out perfect flares above die block, then automatically burnishes flare face. Slip-on yoke permits use in tight quarters. Heat treated dies grip tubing without scoring. Flares and burnishes: 3/16", 1/4", 5/16", 3/8", 1/2" and 5/8" O.D. tubing. Wt. 1-1/2 lbs. Works on some Stainless Steel Tubing but not warranted for Stainless. P/N 507-FB\$104.95



ROLO-FLAIR FLARING TOOL 37°

Operates on same principle as Imperial #507-FA but flares 1/8" (primer line) and 3/4" tubing as well. Size: 4"W x 4"D x 8"H. Wt. 2-1/2 lbs. Excellent tool for bench - not for close-quarter work. Not for use on Stainless Steel Tubing. P/N 212FB\$78.35



DELUXE 37° FLARING TOOL

Forms 37° flare to AN standards in steel, stainless steel (including MIL-T 6845), titanium, an other metal tubing. Three rollers in flaring cone roll out 37° flare above die block. Extension on yoke for clamping in vise. Furnished in plastic kit. Wt. 2-1/2 lb.

P/N 400-F.....\$472.95

TO

RIVET SQUEEZERS – RIVET SETS

37° FLARING BLOCK FOR 1/8" TUBING

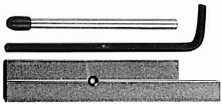

This tool is designed to flare 1/8" tubing for primer lines. Leaves no ridges or marks on tubing, complying with aircraft requirements. Furnished with 37° flaring punch. The slip-on yokes of most flaring tools also fit this block.
P/N 17010..... **\$19.35**

37° DOUBLE LAP FLARING TOOL

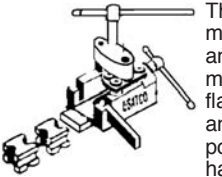

This U.S. made 37° Double Lap Flaring Tool makes flares to AN standards in soft copper and aluminum tubing for 3/16" – 1/2" O.D. Also makes single 37° S.A.E. standard and oversize flares. Adapters revolve for quick size change and act as positioning gauge for tube. For portable use or can be vise mounted. Sliding handle gives maximum leverage. Wt. 4 lbs.
P/N 12-00205 **\$595.00**

37° DOUBLE LAP FLARING TOOL KIT

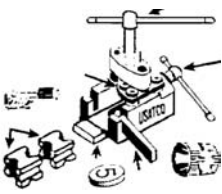

Our 37° Double Cap Flaring Tool Kit includes the double lap flaring tool above which forms 37° double lap flares to AN10078 in soft copper and aluminum tubing (wall thickness to .040"). Flares tubing sizes 3/16", 5/16", 3/8", and 1/2" O.D. Also includes a tubing cutter, an inner-outer reamer, and a plastic carrying case. A quality tool kit which is made in the U.S.A.
P/N 12-00210 **\$597.00**

SPRING TENSION CLAMPS

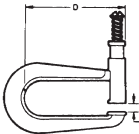

Spring tension clamps can be applied in a fraction of the time required for ordinary screw clamps. The AT542 clamp, with 2" throat depth, has a Zamak alloy yoke and a steel spring which provides a 70 lb. clamping pressure. Designed for use with sheet holder pliers.
P/N AT542 **\$5.90/ea.**

SIDE GRIP CLAMPS



Designed to hold two or more work pieces together where no holes exist. Clamping force is applied at edge of work. Spring loaded, plier actuated. The lack of a takeup screw makes it impossible to over-tighten and damage the work surfaces or the clamp. Clamping capacity - 0-1/2". Jaw depth: 1/2" and 1". Length: 2-3/16".
P/N SC-1/2-1 **\$2.25/ea.**

AT-114C3 QUICK-CHANGE RETAINER SPRING



Makes possible the changing of rivet sets without removal of retainer spring. For .402" shank dia. rivet sets.
P/N AT-114C3 **\$4.15/ea.**

AT 107A FLUSH RIVET SETS



Large radii at critical points to prevent breakage. Slightly crowned, highly polished face designed for rapid flush riveting where a smooth skin surface is essential. Shank dia. .401".

Part No.	Face Dia.	Length	Price
AT-107A-1	1"	2-3/4"	\$15.40
AT-107A-3	1-1/4"	3-3/4"	\$18.80

AT 100A STRAIGHT RIVET SETS



Cup surfaces are highly polished and guaranteed to conform with rivet heads. Carried in stock in AN470 (MS20470) universal-head cup shape. Overall length, 3-1/2", .401" dia. centerless-ground shank.

AT-100A-3-3/32	3/32"	\$5.75
AT-100A-3-1/8	1/8"	\$7.80
AT-100A-3-5/32	5/32"	\$8.40
AT-100A-3-3/16	3/16"	\$7.40

AT 101A OFFSET RIVET SETS



Same tool as AT100A but has 10° bend 1" back from the cup to allow added clearance. Permits easier riveting where obstructions are encountered.

AT-101A-3-3/32	3/32"	\$7.90	AT-101A-3-1/8	1/8"	\$8.35
AT-101A-3-5/32	5/32"	\$7.40	AT-101A-3-3/16	3/16"	\$8.80

HAND RIVET SQUEEZER



Designed to squeeze 1/16" - 5/32" rivets and dimple 1/16" - 3/16" in material up to .040" thickness. Takes standard 3/16" shank rivet squeezer sets. With adjustable ram and 2-piece C-yoke of heat treated 4130 steel. Throat depth: 1.25". Gap: 1-1/4". Overall length: 14". Best quality squeezer on the market. **Made in USA**
P/N 12-00300 **\$131.95**

YOKES FOR RIVET SQUEEZER

1-1/4" X 1" Reach	P/N 12-00308	\$51.75
1-1/4" X 1-1/2" Reach	P/N 12-00309	\$51.75
1-1/4" X 2" Reach	P/N 12-00310	\$63.75
2" X 2" Reach	P/N 12-00315	\$78.00
1-1/4" X 2-1/2" Reach	P/N 12-00318	\$71.00
1-1/4" X 3" Reach	P/N 12-00320	\$78.00
1-1/4" X 3-1/2" Reach	P/N 12-00321	\$93.75
1-1/4" X 4" Reach	P/N 12-00322	\$106.95
1-1/4" X 5" Reach	P/N 12-00323	\$142.95
1-1/4" X 6" Reach	P/N 12-00324	\$166.95

SWIVEL HAND RIVET SQUEEZER



This tool incorporates a 3/8" stroke and 5/8" ram adjustment. The full 360° yoke can be locked in any position in relation to the handles. Uses standard squeezer sets with 3/16" shank diameter. Yoke depth: 1-1/2".
Model AT502AH-D **\$244.95**

INSTRUCTIONS FOR SELECTING RIVET SETS

To develop maximum power, the riveter must drive the rivet near the end of the riveter's stroke. For maximum power the combined length of the two rivet sets must be of the correct length. Determine the correct length as follows:

WHEN TWO CUPPED RIVET SETS ARE USED – The sum of the two rivet sets "L" dimension should equal the closed height dimension of the yoke minus the total thickness of the material being used.

WHEN TWO FLUSH SETS ARE USED – The sum of the two rivet sets "L" dimension should equal the closed height dimension of the yoke minus the overall length of the rivet after it is driven.

WHEN ONE CUPPED SET & ONE FLUSH SET ARE USED – The sum of the two rivet sets "L" dimension should equal the closed height dimension of the yoke minus the total thickness of the material being riveted and the height of the finished rivet head driven by the flush set. If necessary, select rivet sets a little short and shim to proper length with hardened shims listed in the table. The closed height dimension of the yoke referred to above is the opening available when jaws of plunger are in extreme closed or forward position with both rivet sets in place.

RIVET SETS FOR SQUEEZER



Assorted Squeezer Set. 5-piece, consisting of rivet sets for 3/32, 1/8 and 5/32 AN470 rivets, and one flat set. Shank dia. 3/16".
P/N 26-5 **\$21.40**

DIMPLING SETS FOR SQUEEZER

FASTENER	AN 426 RIVET			
	3/32	1/4	5/32	3/16
SIZE	-3	-4	-5	-6
DASH NO.				
BODY LENGTH	1/4	3/8	1/2	
	DASH LETTER	-P	-R	-S

When ordering, specify:
Basic Part No. - Rivet Size
No. - Body Length, Letter.

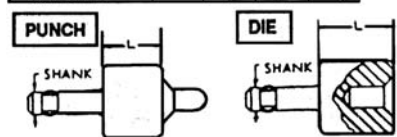

P/N's per set	1 punch	1 die
207/206-3-P	207/206-5-P	
207/206-3-R	207/206-5-R	
207/206-3-S	207/206-5-S	
207/206-4-P	207/206-6-P	
207/206-4-R	207/206-6-R	
207/206-4-S	207/206-6-S	

\$27.90/set

INDIVIDUAL SETS

CUPPED SQUEEZER SETS

"L" Dim.	Part No.	Price Ea.
1/8"	AT108AN-	\$5.00
1/4"	AT108AP-	\$4.80
3/8"	AT108AR-	\$5.50
1/2"	AT108S-	\$4.80

FLUSH RIVET SETS

"L" Dim.	Part No.	Price Ea.
1/8"	AT109AN	\$3.10
1/4"	AT109AP	\$3.00
3/8"	AT109AR	\$4.30
1/2"	AT109AS	\$3.75

NOTE: Complete P/N with -3/32, -1/8, -5/32, or -3/16 for rivet diameter

TO

COUNTERSINK CUTTERS

MICROSTOP/COUNTERSINK CUTTER KIT



This kit provides countersinking versatility with nine different 1/2" diameter cutters, six of the most commonly used foot pieces, and a high-speed bearing-constructed microstop. The microstop controls cutting depth in .001 increments, from 0 to 5/16". Cutters-ground on-centers to ensure concentricity-are 100°, with pilot diameters #40, #30, #21, 3/32", 1/8", 3/16", and 1/4".

P/N 590CSK\$199.85

100° AT455 COUNTERSINK CUTTER

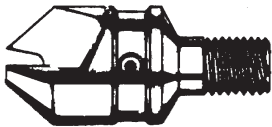

Designed for operating in angle drills with 1/4-28 threads and in the AT441SLS Micro Stop Countersink. Has 1/4-28 threaded shank. Cutter angle 100°. AT455D-4 has 7/16" dia. cutter head. Use with AT484 pilots.

P/N AT455D-4.....\$11.30



AT484 PILOTS

AT484 replaceable pilots have a .086" dia. shank with a flat to accommodate the set screw of the AT455 cutter. An undercut permits the head to seat on the cutter angle. Order by P/N

\$7.50 ea.

Part No.	Head Dia. "D"	Part No.	Head Dia. "D"
AT484-2	#40	AT484-56	3/32
AT484-12	#30	AT484-57	1/8
AT484-21	#21	AT484-59	5/32
AT484-31	#11	AT484-61	3/16
AT484-32	#10	AT484-63	7/32

AT441 HSS MICROSTOP COUNTERSINK

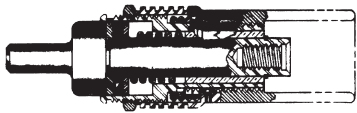

AT441 HS Micro Stop Countersink, similar to the AT442SLS unit, except with 1/4-28 female threaded nose to accommodate AT455 cutter.

P/N AT441-HSS\$26.85

AT 442 HS MICRO STOP COUNTERSINK

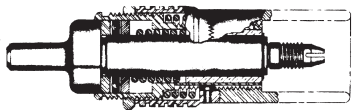

A precision tool for production countersinking. Ball thrust bearing for absolute depth control. Adjusts in .001" increments, with positive adjustment lock. Skirt accepts cutters up to 5/8" dia. Has 1/4-28 male threaded shaft for use with AT418 cutters. Can be assembled and disassembled without special tools. Split shaft and taper locks pilot in place when cutter is tightened. Order cutters and pilots separately.

P/N AT442-SLS\$56.00

MICRO-STOP COUNTERSINK CAGES AND NYLON FOOT PIECE



2 Models available-one with NEEDLE bearing and one with BRONZE bushings. .001" increment depth adjustment. Positive adjustment lock. 1/4" dia. shank. 9/32" shaft travel. 9/16" cutter capacity. For 1/4-28 threaded cutters. Comes with "NO-MAR" foot piece. Rated at 3,000 RPM. Made in USA.

With Bronze BushingsP/N 12-01412\$38.50

With Needle BearingsP/N 12-00940\$39.80



BRAKE RIVET SET

Use these sets with your hand squeezer. Will set brake rivets eliminating the possibility of cracking your brake pads.

P/N 12-00550\$33.60

AT 409 SERIES STRAIGHT SHANK COUNTERSINK WITH INTERCHANGEABLE CUTTERS AND PILOTS

Assembly, consists of AT418E (1/2") cutter, AT416 pilot and AT409-1, 1/4" straight-shank. Has a collect-type shaft to securely hold the replaceable pilot.

When ordering specify: Part number of cutter and pilot dia.

Assembly Example: AT409 with 100° cutter A418E & 1/8 pilot.

(AT416-57)Adapter only.....P/N AT409-1\$8.20

AT418 STOP COUNTERSINK CUTTERS

Three-straight flute replaceable pilot cutters with female thread. These cutters are designed with extra deep flute to permit numerous resharpenings and radial clearance to assure fast smooth cutting.

For Replaceable Pilots Refer to AT416 Series.....Used With AT418

Part No.	Cutter Dia.	Thread Size	Pilot Hole	Price
AT418A-4	1/4"	1/4 - 28	.086	\$24.00
AT418D-4	7/16"	1/4 - 28	.086	\$29.20
AT418E-4	1/2"	1/4 - 28	.086	\$29.85

120° AT418 COUNTERSINK CUTTER

Same type cutter as described above except with 120° Cutter Angle. 7/16" Cutter Diameter. P/N AT418D-7\$37.80

AT416 PILOTS

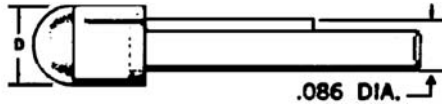

Fit AT418 cutters. Undercut permits head to seat on cutter angle. Order by Part No. in table below. Order by part Number. \$7.60 Ea.

Part No.	Head Dia. "D"	Part No.	Head Dia. "D"
AT416-2	#40	AT416-56	3/32
AT416-12	#30	AT416-57	1/8
AT416-21	#21	AT416-59	5/32
AT416-31	#11	AT416-61	3/16
AT416-32	#10	AT416-63	7/32
		AT416-65	1/4

BRAKE LINING & GENERAL RIVET SETS



Standard Model - Designed especially to economically reline brakes, this riveting set is a handy tool for many other jobs where rivets are used to fasten leather, canvas, plastic & metal parts.

P/N 824\$15.95

Brake lining RivetsP/N 06-02300\$0.03ea

Deluxe Model - Our deluxe model brake relining tool makes it virtually impossible to botch a brake relining job. The threaded screw action of the rivet insertion tool insures a perfect roll on brake rivets every time without damaging the liner. P/N 12-20810\$22.65

Replacement Parts

(a) AnvilP/N BR-1005\$3.95/ea.

(b) Knockout PunchP/N BR-1006\$3.60/ea.

(c) Rivet SetP/N BR-1007\$7.30/ea.

PARKER TYPE AIRCRAFT TUBE BEADING TOOL

The Parker Beading Tool has been the number one choice of aircraft mechanics for making clamping beads in metal tubes. To this day, no other tool even comes close to matching its quality. So by special arrangement, the manufacturer tooled up to recreate this classic tool in every detail. In the process they have added a few enhancements of their own, such as ground, hardened, and polished surfaces for mar-free beads in aluminum, copper, brass, and mild steel tubes ranging from 1/4" to 1" diameter. Meets MILSPEC MS33660D and SAE AS5131 standards. P/N 12-01049\$374.95

PLIERS – PUNCHES – BRAKES



Hand Seamer w/Tapered EndsP/N 44R\$20.85

HAND SEAMER

Large jaws are machined for smooth, parallel fit. Forms precise folds and seams. Has rounded jaws to prevent tearing when bending of aluminum and other light metals. Depth of throat 1". Width of jaws 3-1/2". Overall length 8".....

P/N 12-00620\$42.60



ROPER-WHITNEY METAL CRIMPER

Handy crimping tool to disperse excess metal. Depth of throat 1-1/8". Overall length 9". Wt. 1 lb. P/N 111.....\$49.95



ROPER-WHITNEY NOTCHER

Designed for fast, accurate 32° notch in sheet metal. Hook design of jaws permits notching to exact desired depth without slippage. Spring-return jaws. Capacity 20 ga. Wt. 1 lb. P/N 141.....\$79.75



FLUTING PLIERS

These aircraft-type fluting pliers are a drop-forged quality tool. Non-marring working surfaces of jaws specifically designed for use on aircraft components. Comfort grip handles. P/N 12-00500\$15.30

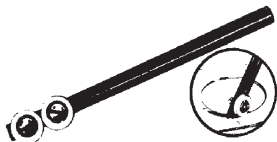

HOLE FLANGING TOOL

A real time saver for flanging lightening holes. Non-marring. Easy to use. Nylon rollers and ball bearings assure long life. P/N 12-00600\$16.95

MIGHTY ROD SHEET METAL BENDER



USA. • 1 year Replacement Warranty.

Designed to bend solid round, square and flat alloys into nearly any shape and angle. **FEATURES:** • Works on solid materials up to 3/8" diameter. • Coils and bends wires of many sizes. • Includes dies for 1/2", 3/4", 1", 1 1/4" & 1-1/2" diameter bends. • Constructed of 3" x 3" aluminum base 1" thick with a 12" handle 7/8" in diameter. • Made in the USA. P/N 12-00934\$28.70

JUMBO ROD SHEET METAL BENDER



Bends metal to any shape and degree of angle. • Include dies for 3/8", 3/4", 2", 3" & 4" diameter bends. • Installs on any vise. • Ideal for hobbyists, prototype shops and do-it-yourselfers. • Made in the USA. P/N 12-00935\$55.75

Constructed of 4" x 6" aluminum base 1" thick with a 16" handle 7/8" diameter. Bends solid round, square and flat iron.

FEATURES: • Works on solid materials of up to 3/8" round and square (1/2" wide flat). • Coils and bends wire of many sizes. •

MAGNUM BENDER



For many homebuilders, the production of high quality aircraft metalwork can be a daunting prospect. There can be hundreds of intricate fittings to produce and many will require accurate bending. Magnum bender uses sets of interchangeable bending bars each with two different radii to produce high quality bends, up to, and including 90 degrees. Bending bars are hardened and polished and allow for material 'spring back'. The Magnum Bender is available as either a standard version with 1/16", 3/32", 1/8", 5/32", 3/16" and 1/4" radii. Or, as a metric version, with 3 bending bars offering 1,2,3,4,5 and 6mm radii. Each machine is supplied with two pairs of operating levers, 1 ft. long and 2 ft. long. An optional 24 piece Clamp kit is also available.

Standard versionP/N 12-01550.....\$1,065.00
Metric version.....P/N 12-01551.....\$1,065.00



#5 JR. HAND PUNCH – with one ton punching power. Punches 1/4" hole through 16 Ga. mild steel. Throat clearance 1-3/4". Complete set in metal box with 3/32, 1/8, 5/32, 3/16, 7/32, 1/4 and 9/32" punches & dies. Wt. 4-1/4 lbs. P/N 12-01600.....\$78.75



BENCH MOUNT BASE – for stationary use. Base swivels to any position. Punch is held by L-shaped clamp rod through a 7/16" or larger hole in bench. P/N 12-01700.....\$28.70

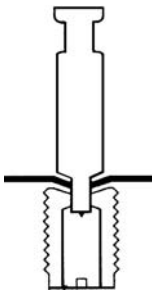

STRAIGHT PUNCH & DIE SETS – for No. 5 Jr. punch in the seven sizes shown below.

3/32"#12-01800	7/32"#12-02200
1/8"#12-01900	1/4"#12-02300
5/32"#12-02000	9/32"#12-02400
3/16"#12-02100	Each Size\$11.60/set

COMBINATION PUNCH & DIMPLING DIE SETS – For #5 Jr. punch. Punch and dimple in one operation. 3/32, 1/8 or 5/32" 100° punch & dimpling die sets.

1/8"#12-02500\$57.30
3/32"#12-02600\$53.60
5/32"#12-02700\$54.65

ECONOMY MODEL BENDING BRAKE

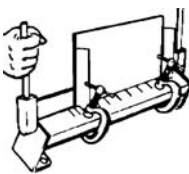

For bending and forming. Makes clean, smooth bends and forms up to 90° in metals. 18" & 30" handle up to 16GA aluminum. 40" handles is up to 20GA sheet metal, 18GA aluminum. All include brake bars. Clamps not included. Made in USA.

Up to 18" width stock..P/N 12-02800\$29.85
Up to 30" width stock..P/N 12-02810\$89.25
Up to 40" width stock..P/N 12-02815\$246.95

HEAVY DUTY BENCH BRAKE

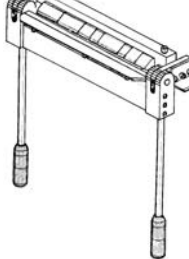

This small, compact brake is excellent for all tough fabrication and repair jobs. The radiused dies make it possible to form those difficult materials such as 2024T3, 4130, and stainless without fear of cracks. Features solid steel bar construction, heavy duty clevis hinges, and portable bench mounting. Includes 2 sets of assorted width reversible dies with 1/16", 1/18", and 3/16" radii, plus complete instructions. Ideal for machine shops, aircraft, race car, boat builders, avionics installers, & auto repair shops. P/N 12-02850\$1,455.00

ORIGINAL LANCASTER PORTO-METAL FORMER



The Porto-Metal Former makes the specialty angle needed in minutes. Can be used on the work bench or in a vise to make inside angles, outside angles, straight bends - even circles, to a radius as small as 3". Jaws are made of hardened alloy steel. Works 18 gauge soft steel, 20 gauge stainless, 16 gauge aluminum up to 2" in width. 45 to 1 leverage for powerful press. Special malleable iron body will not break as we have found with cheaper imitations. Order #LSH-71 metal shrinker for inside angles. Order #LST-82 stretcher for outside angles. Wt. 12 lbs. each.

#LSH-71 ShrinkerP/N 12-19800\$166.95
#LST-82 StretcherP/N 12-19900\$164.95
Combination Shrinker/Stretcher Tool....P/N 12-02950\$247.95

Either unit can be converted into its opposite by ordering complete conversion kit, includes jaws, blocks & wire.

Shrinker (#12-02900) or Stretcher (#12-02910) Conversion Kits Assemblies\$138.95

Mounting Plate - installs on shop vice to allow mounting of shrinker and stretcherP/N 12-00494\$49.75

TO

RIVET GUNS

CHERRY G-28 POP RIVET HAND GUN



The G-28 hand gun is a quality Cherry Rivet tool for installing commercial "Pop" rivets. Furnished with two nosepieces - one for 3/32" and 1/8" rivets and one for 5/32" and 3/16" rivets. Wt. 13 oz.
P/N 12-03000\$111.95



CHERRY G-28 POP RIVET GUN KIT

Consists of the above G-28 gun and a selection of 5 popular sizes of Cherry "N" rivets packaged in an attractive high-impact plastic storage box.
P/N 12-03100\$158.95

CHERRY G-29 HAND RIVETER

Efficient, compact, lightweight tool for installing Cherry® Nut-Plate rivets. It comes equipped with a 728A9-3 nosepiece to install 3/32" rivets and has a 728A9-104 nosepiece stored in the handle for installing 1/8" rivets.
P/N 01-00213\$142.95

CHERRYMAX G-27 HAND RIVETER KIT

The G-27 is a light weight (13 oz.) hand tool for use in low production applications. It is packaged in a rugged plastic case with room for an assortment of popular usage rivets. The pulling head is an integral part of this riveter.
P/N 12-03105\$118.95

120° FLUSH DIMPLING TOOL

This unique tool for 1/8" 120° countersunk "Pop" rivets attaches to the Cherry G-28 standard hand "Pop" rivet gun. Simple design makes dimpling foolproof, quick and easy, with no cracking of metal. For use on aluminum to .040" thickness.
P/N 17014\$7.40

ADJUSTABLE RIVET SPACER

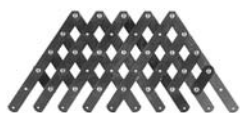

For uniform spacing of rivets, bolts, nails, etc. Unique fan design expands to 36". Equally spaces up to 20 holes between 2 given points. Made of 301 stainless steel.
P/N 12-11700\$36.25
10 Hole spacerP/N 12-00184\$19.70



RIVEDRILL™

Allows operators to set up to 14 rivets per minute - twice as many as can be set by standard hand tools. The RiveDrill is ergonomically friendly, requiring just 6.6 lbs. of pressure to operate, compared to 77.2 lbs. required for hand tool operation. Excellent for working on aircraft, autos, or boats. The

RiveDrill™ can be quickly inserted into a 3/8" reversible power drill as any standard drill bit would and is able to set any standard blind rivet up to 3/16" aluminum. The shank of the rivet is expelled when the drill is operated in the "reverse" mode. (For cordless electric power drills, a minimum 12V battery is recommended.) Nosepieces for 1/8", 5/32", & 3/16" sizes are included. **RiveDrill™ Specifications:** • Model 110 • Wt: .618 Lbs. (280 grams) • Length: 5.5 in. (144.1 mm) • Diameter: 2.4 in. (60 mm) • Battery for cordless drill: 12V • Nosepieces included: 1/8", 5/32", 3/16" • Drill Types: Cordless, Electric, Pneumatic • Rivet capacities: 1/8", 5/32", 3/16" aluminum standard rivets; 1/8", 5/32" steel standard rivets; 1/8" stainless standard rivets.
P/N 12-00253\$49.95

ULTRALITE NUTPLATE DRILL MOTOR



Ergonomic, lightweight design. Only one hand required to locate, drill & countersink both holes. Easily convert rivet spacings with interchangeable foot attachments. Available in single wing, double wing & mickey mouse models. Accommodates all nutplate spindle spacings from 0.219" to 1.125". Fully adjustable feed rate. 600 or 7,000 RPM
P/N 12-01376\$2,494.00

SWIVEL RIVETING TOOL



Rotates 360° and rivets in any position. High leverage handles for added power. Hardened steel construction for long life. Extended nose for hard to reach places. Will pull 3/32", 1/8", 5/32", and 3/16" rivets. Model TP844P/N 12-00365\$51.50



ATS AIRCRAFT RIVET GUN #2602

So controllable you can easily buck rivets as small as 3/32" to as large as 3/16".
P/N 12-18340\$93.50

RIVET SET MAX FOR 2602 RIVET GUN

3/32", 1/8", 5/32" and 3/16" rivets.
3-1/2" (5 pcs. straight, includes flat).....P/N 12-18341\$29.75
3-1/2" (4 pcs. offset).....P/N 12-18342\$26.80
5-1/2" (4 pcs. straight)P/N 12-18344\$25.70

POWERLINK 30 POP RIVET HANDTOOL



The PowerLink 30 is the world's first ergonomic hand rivet tool, and is 50% easier to use than other hand tools. A patented compound link design does the work for you. A shorter grip opening ergonomically designed for one hand operation. Grips cover the length of the lever and body, and soft handles are contoured to fit the hand. A unique front end design provides jam free operation, and a shorter new housing allows the tool to easily fit in a back pocket. The wrench and nosepieces (3/32", 1/8", 5/32", & 3/16") are stored in the handle of the tool. Excellent for use on Cherry and other standard pop rivets.
P/N 12-00178\$48.70



HEAVY DUTY RIVETER

Includes four nosepieces to set rivet diameters from 3/32" up to 3/16". Convenient lock chain keeps handles closed when tool is not in use. Made in U.S.
P/N 12-18352\$29.95

RIVET TAPE

3/4" green tape with clear center strip.
P/N 12-183557.85

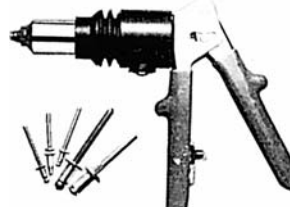

COMBINATION RIVET-RIVNUT TOOL

The D100-RN hand operated hydraulic tool is ideally suited to the needs of the aircraft homebuilder. The tool develops 3,500 lbs. of pulling force which permits the installation of all Cherry Commercial Blind Rivets or any other Pop type rivets through 1/4" diameter as well as all CherryMax rivets through 3/16" diameter. Will not pull Cherry Lock rivets. The D100-RN quickly converts to a threaded blind nut setter to allow efficient installation of Rivnuts or similar blind nuts. The kit includes the D100 hydraulic tool with adapters for blind rivet and blind nut installation, rivet nosepieces for 1/8", 5/32" and 3/16" diameter blind rivets, blind nut pull-up studs with nosepieces for 6-32, 8-32, 10-32 and 1/4-28 Rivnuts, operating instructions and a rugged Plastic storage case. Size: 12-1/2" x 8-1/4" x 3". Weight: 3 lbs.
P/N D100-RN Kit\$274.95

PNEUMATIC-HYDRAULIC BLIND RIVETER

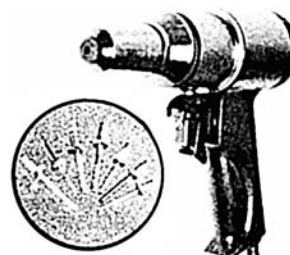

The PT-100-1 power riveter, no larger than a compact drill motor, will install virtually any straight-pull blind rivet with installation loads of 3500 lbs. or less. All blind rivets from 3/32" dia. up to and including 1/4" dia. CherryMax rivets can be installed with the P-100-1. It utilizes a patented two-valve hydraulic pump actuated by 90 to 130 PSIG air pressure. Unlike most riveters, the P-100-1's collect/jaw assembly while the outer sleeve-nosepiece assembly is hydraulically moved, creating sufficient load to install the rivet. Furnished with three nosepieces for 1/4", 1/8", 3/16" & 3/32" rivets. Wt. 29 oz.
P/N PT-100-1\$513.00

TO

RIVNUT TOOLS – TAPE MEASURES

L-6000 RIVNUT SPEED DRIVER

This tool is designed for light production and features high speed push-pull, smooth, spiral action. Sized #4 through #10 adequate for brass, aluminum, and steel. Sized #4 through #8 adequate for stainless steel. Provides easy on-and-off threading of rivet nut with push-pull knob. Adjustable anvil for different length rivet nuts. Made in U.S.A. The C-6000 Speed Header is available for Rivnuts with the following thread sizes:

6-32P/N 12-12600\$114.95 8-32P/N 12-12700 \$114.95
 10-32P/N 12-12800\$114.95 1/4-28 ..P/N 12-12900 \$114.95

CONVERSION KIT - For changing speed header to a different Rivnut thread size. Order by P/N .

6-32 Kit.....P/N 12-13000\$31.30 8-32 KitP/N 12-13100 ..\$29.30
 10-32 Kit....P/N 12-13200....\$31.30 1/4-28 Kit ..P/N 12-13300 ..\$45.90

L-7000 RIVNUT SPEED DRIVER

Designed for light production. Same as the L-6000 except made with a longer stroke for slotted rivet nuts. Made in U.S.A. Order by part number. **Available in the following thread sizes:** 6-32 (P/N 12-13605), 8-32 (P/N 12-13610), 10-32 (P/N 12-13615), and 1/4-28 (P/N 12-13620) **\$146.95/ea.**

C-845 ECONOMY RIVNUT TOOL

Model L-845 wrench type rivnut tool is for field repair & experimental use. Adequate for aluminum, brass, steel, and stainless. Made in U.S.A. Order by part number.

Available in following thread sizes:

6-32 ..P/N 12-13400 ..\$41.40 8-32P/N 12-13500..\$41.40
 10-24P/N 12-13600)..\$41.40 10-32 ..P/N 12-13700..\$41.40
 1/4-20P/N 12-13800)..\$41.40 1/4-28 ..P/N 12-13900..\$41.40

L722 WRENCH TYPE RIVNUT TOOL

L722 Wrench Type Riv-Nut installation tool for the larger size fasteners 5/16" up to 1/2", tool comes with long arm allen wrench with plastic handle for easy installation.

L722 wrench type header	Part No.	Price	L722 wrench type header	Part No.	Price
5/16-18	12-00920	\$42.30	5/16-24	12-00921	\$42.20
3/8-16	12-00922	\$42.20	3/8-24	12-00926	\$42.20
1/2-13	12-00927	\$71.50	1/2-20	12-00928	\$71.50
M10	12-00930	\$68.00			

WRENCH TYPE RIVNUT TOOL

Kit includes: TP726A, TP726B, TP726C, TP726N, and handy case. •Perfect for field repair and experimental use • Easy to use - inserts from one side of the work in seconds • Excellent for close quarters, overall height less mandrel 1-1/2" • Uses 3/4" open end or socket wrench • TP726N Notcher manually operated • Made in the U.S.A.

Model	Part No.	Price
TP726A / 6-32	12-00348	\$44.70
TP726B / 8-32	12-00349	\$39.80
TP726C / 10-32	12-00350	\$36.60
TP726N/Notcher	12-00351	\$20.85
TP726K / Kit	12-00352	\$148.95

L-1000 ECONOMY HAND RIVNUT TOOL

The L-1000 economy hand rivnut tool is recommended for slotted rivet nut fasteners. Adequate for aluminum, brass, steel and stainless steel fasteners. Made in U.S.A. Order by part number. L-1000M is same tool, except in metric sizes.

Model	Thread Size	Part No.	Price Ea.
L-1000	(60-32)	P/N 12-13645	\$36.60
L-1000	(8-32)	P/N 12-13650	\$36.60
L-1000	(10-32)	P/N 12-13655	\$35.40
L-1000	(1/4-28)	P/N 12-13660	\$36.60
L-1000M	(M6)	P/N 12-13675	\$42.60



HEAVY DUTY RIVET CUTTER

This high quality, durable rivet cutter features all steel construction and cuts 1/16" to 1/4" diameter rivets. It is adjustable for 1/4" to 3/4" long rivets. P/N 12-16840\$41.60



RIVET CUTTER

This handy rivet cutter, w/ 2 hardened blades, cuts rivets of any standard dia. from 3/32" to 3/16" without burring. The length of the cut rivet can be varied from 3/16" to 5/8" by means of 8 adjustable leaves attached to the cutting head. Plastic coated grips. Wt. 2 lbs. P/N 12-00200\$12.95



AT501R RIVET CUTTER

This heavy duty rivet cutter is designed to quickly and easily shear aluminum rivets. It is adjustable for 1/4" to 3/4" long in 1/16" increments. It will accommodate 3/32", 1/8", 5/32", 3/16", 1/4" and 7/32" diameter rivets. P/N AT501R\$39.95

BENCHTYPE RIVET CUTTER

Cuts 5 different diameter rivets, as well as wire and screws to 7 different lengths. Made of hardened and ground steel, this rivet cutter can be easily fastened to a workbench or held in a vise. Accepts rivet diameters 1/16, 3/32, 1/8, 5/32, 3/16, Will cut to lengths: 5/32, 7/32, 9/32, 11/32, 15/32, 17/32. P/N 12-00262\$119.95



LUFKIN METRIC/INCH TAPE MEASURE

LUFKIN NO. W9210ME Has 1/2" blade, 3 meters long (equal to about 10 ft.). Markings are on one side only, with millimeters on upper edge and inches to 16ths on lower edge. White face. P/N 12-19700\$9.95

Replacement Blade (RY23CMF)P/N 12-19750\$6.10

STANLEY DECIMAL INCH TAPE MEASURE

This 12-ft. steel tape measure with 1/2" blade is graduated in tenths & hundredths of inches and also in fractions of inches (32^{nds}). Very handy for all aircraft construction. A must for building composite aircraft. P/N 33-272\$14.85



UNI-MAG WRIST BAND MAGNET

Uni-Mag is a wrist worn magnet that allows craftsmen to keep parts close to hand while working rather than in your pocket, on a ladder, or in your mouth. It holds nuts, bolts, screws, nails, tools, etc. A specially created magnetic field allows parts to lay flat on the face of Uni-Mag rather than upright. Save time and put an end to fumbling for small hardware with Uni-Mag. Comes complete with magnet and wristband. P/N 12-30110\$13.30

RIVET CONVERSION KITS

Converts your conventional hand pop riveter into an economical RivNut installer tool.

Size	Part No.	Price
6-32	12-13680	\$11.80
8-32	12-13681	\$12.65
10-32	12-13682	\$12.65

HOMEBUILDERS RIVET NUT TOOL

This rivet nut tool is an inexpensive alternative to industrial rivet nut setters. Fast and easy to use for the builder who needs to make sturdy installations requiring a rivet nut fastener. It has unlimited uses. Its design enables the rivet nuts to be seated tighter than with conventional tools. This fastening tool has unique uses! The rivet nut possesses far greater load bearing capability than a regular sheet metal screw! Proudly made in U.S.A. Use it instead of a sheet metal screw. Its compact design takes up less room in your tool box. For use with aluminum or steel rivet nuts. Kit includes Rivet Nut Tool, Stabilizing Rod, Drill Bits & 6-32, 8-32 & 10-32 rivet nuts. P/N 12-00968 ..\$16.95

TO

TOOLS

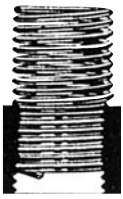

RECOIL KITS

The Recoil System is the simple way to repair stripped or damaged threads. It provides stronger and more efficient threads which have great holding power. The system is quick and easy to use and is ideal for alloys and other light materials. The recoil insert, which is larger in diameter than the tapped hole, is compressed during installation then allowed to spring back, permanently anchoring into place. The Recoil System consists of Recoil stainless steel helically wound precision inserts, high quality HSS taps and installation tools.

Recoil stainless steel helically wound precision inserts, high quality HSS taps and installation tools.

KIT P/N	SIZE	INSERTS PER KIT	PRICE
34600*	3/16 - 10-32	10	\$36.90
34040*	1/4 - 28	10	\$38.90
34050*	5/16 - 24	10	\$41.40
33050**	5/16 - 18 (UNC)	10	\$47.50
34060*	3/8 - 24	10	\$41.50
34070RC*	7/16 - 20	5	\$47.70
34080*	1/2 - 20	5	\$66.75
35060***	M6x1 (Metric)	10	\$36.90
35080***	M8x1.25 (Metric)	10	\$46.00
33004**	UNC Range Kit	50	\$203.95
34004*	UNF Range Kit	50	\$226.95

*UNF - Unified Fine Thread **UNC = Unified Coarse Thread
*** Metric = Metric & Spark Plug (ISO)



KWIKSCRIBE™

Kwikscribe is a remarkable layout tool for fabricators, engineers, and machinists. Saves time in making layouts from 1/8" to 1". Very popular with auto fabrication shops and aircraft repair shops. Set of 3. P/N 12-00372\$19.90

BLIND SKIN SCRIBE

For use on flush skin butt joints. This tool quickly and easily finds the cut line on the overlap of new metal. The lower leg slides under the new metal and hooks on the adjacent skin and the upper leg scribes the new skin as it pulled along. This tool is adjustable to suite the desired gap at the skin joint. This tool is especially handy when the old skin that is removed is damaged beyond usefulness as a pattern Note: For use on aluminum only. P/N 12-00746\$33.75

6-IN-1 COMBINATION SCREWDRIVER



#1 Phillips, #2 Phillips

- Industrial rated bits for extra long life
- Heat treated 1/4" & 5/16" nut drivers
- Interchangeable bits fit both Phillips & Slotted screws
- Bits: 3/16" Slotted; 9/32" Slotted;

P/N 12-14000\$6.95

SCREWSTICK POCKET SCREWDRIVER

The Screwstick is a pocket screwdriver which accepts any common 1/4" tip. An extra tip is stored in the stainless steel shaft, and a heavy duty magnet holds tips firmly in place. A steel torque driver for stubborn applications is stored in the shaft. A rubber finger grip for holding plus a heavy duty pocket clip are included. Ideal for aviation, automotive, & many other applications. Great for mechanics. P/N 12-20105\$3.95



MASTER CHUCK

These versatile Master Key Chucks are available in two sizes (small & large) which open sizes 1/4" to 3/4". These tools allow you to open over 1200 different key chucks. Save wear on chucks by always having the proper key size available. The squared center of the keys opens acetylene tanks. Made of treated steel with black oxide finish.

SmallP/N 12-30165\$11.90
LargeP/N 12-30170\$13.60



SCREW REMOVAL TOOL

P/N TP-328\$28.60

BOJO PLASTIC PRY TOOLS

Soft, yet strong, all Bojo tools are made tough enough to pry, but not hard enough to damage. These 4 tools are provided as a set.



PLASTIC GENERAL WEDGE TOOL - General narrow point for reaching in narrow spaces.

PLASTIC STICKER/GASKET TOOL - Wedge tip, for use where a wide area is desired with a "soft" touch.



PLASTIC PRY BAR TOOL - The forked tip. The original for removing door panels and plastic grommets.

PLASTIC WEDGE PULLER TOOL - The forked tip. The original for removing door panels and plastic grommets.



SET OF 4P/N 12-00748\$14.95



MASTER INSTALLER KIT - Soft, yet strong, all Bojo tools are made tough enough to scrape, but not hard enough to damage. Set of 7.

P/N 12-00976\$19.95



AIRCRAFT ASSEMBLY SCRAPER KIT - Soft, yet strong, all Bojo tools are made tough enough to scrape, but not hard enough to damage. Set of 4.

P/N 12-00977\$15.50

ALL-SHARP DIAMOND SHARPENER

All Sharp is an innovative diamond sharpener that provides 4 different grit sizes on the same tool. All Sharp sharpens and fine sharpens tools and bits and cleans burrs on hard to reach parts and equipment. It's tough stainless body will not rust and All Sharp fits in any tool tray or pouch. Model ST-7. P/N 12-21430\$14.75



SUPERCHAMP IV CRIMPING TOOL

The professional quality crimping tool. This versatile hand tool has a separate set of crimping dies for insulated and uninsulated terminals and splices in wire sizes No. 22 to No. 10 AWG. It has a terminal locator to position insulated terminals during crimping and an in-nose cutter for tight locations. This tool is a wire stripper and has a built-in heavy duty bolt cutter. Color coded dies in tool nose correspond to color on terminal insulation sleeve to insure die selection. A stud gauge and wire stripping gauge are important on the tool body. Cushioned handles. P/N 604252-1\$15.65



BANTAM ROTA-CRIMP TOOL

The AMP Bantam Rota-Tool crimps uninsulated terminals and splices for No. 8 to 1/0 sizes. The correct die position is selected by rotating dies to correct AWG number. Dies are fixed in tool to avoid loss. Compact, rugged and easy to handle. 15" long. Wt. 5 lbs. Not for certified Aircraft use. P/N 601075\$389.95



AT 540M SCREW EXTRACTOR

This heavy duty screw extractor is designed with a .401 shank to fit most standard rivet guns and is held in place by a retainer spring. The square tip will accommodate 3/8" socket tool bit holders with inserts for removing hex, square, Phillips, or standard screws. Manufactured from high grade shock resistant tool steel. P/N AT540M\$9.80

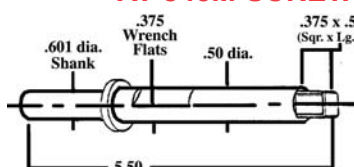

TORK-IT PRECISION TORQUE SCREWDRIVER

The Tork-It Model 36 precision torque screwdriver is a micro-setting device that is adjustable from 2 to 36"-lbs. in 0.5" -lb. increments. The tool complies with ANSI type 3 class A style 1 screwdriver grip torque wrench standards. Tork-It is supplied with a 1/4" pin-lock hex bit holder. 6-piece Hex-Bit set of 1.5mm, 2mm, 2.5mm, 3mm, 3/32 & 7/64" can be ordered separately.

Tork-It ScrewdriverP/N 12-14330\$94.75
Six Piece Hex Bit SetP/N 12-14335\$13.80



TO

LATHES - MILLS

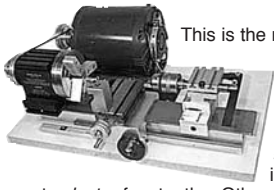

MICRO LATHE

This is the machine you don't have to "baby". The Micro Lathe is a rugged, precision instrument. Its machined, ground and stabilized steel bed has a lifetime ball bearing spindle, coupled with a 6-speed positive v-belt drive. Spindle speeds in geometric progression from 525 to 5200rpm provide the power to "HOG" 1/8-inch cuts in mild steel or the speed and accuracy to *dust* a few tenths. Other big lathe features include large .001 graduations on the cross slide dial, an all-angle tool post and a carriage depth stop. Adjustable gibs provide full compensation for carriage and cross slide wear. 2-yr. factory warranty. 15" bed. Comes factory assembled. **Accessories Included:** The Unit pictured is a basic unit (P/N 12-00171) with an optional 3-Jaw Chuck, Boring bar(1097E), Tailstock (1150), Drill Chuck (1091), 1/4 HP 1725 RPM Motor (1021w), Motor Mount Bracket (1022), Mounting Board (1023), and Pulleys (1162 with 3M 500 belt). All accessories are sold separately and are not included in the base price. Note: Photo shows Lathe with all accessories which are not included (Available separately). P/N 12-00171 is basic lathe unit only.

General Specifications:

- Overall working accuracy: 0.0005"
- Max. bearing run out: 0.0004"
- Headstock normality to bed: .0004 in max. error
- Max. taper bed dovetail over pins: 0.0001"
- All machine dovetails: 45°
- Bed width: 2 5/16"
- Cross slide dial graduation: 0.001
- Cross slide screw: 1/4"-20 adjustment for back-lash take-up provided (jam nut arrangement)
- Carriage travel: 0.600" 1 rev. of hand wheel
- Max. spindle speed recommend: 7000 rpm
- Motor requirement: 1/8 - 1/4 HP
- Pulley type: Std. 5/8" bore, multi-step V-belt
- Length of headstock on ways: 2.875"
- Length of carriage on ways: 3.000"
- Width of cross slide on carriage: 2.000"
- Tool post: may be adjusted for angle cutting (chamfer, boring, etc.)

Capacity:

- Swing over bed: 4.5" (max. turning dia.)
- Swing over cross slide: 2 3/8"
- Overall length of bed: 15.5"
- Overall length of lathe: 16.5"
- Tool bit size: 1/4"
- Drill chuck capacity: 0 to 1/2"
- Distance between centers: 9.75"
- Carriage travel: 9"
- Cross slide travel: 1.75"

Spindle Specifications:

- Sealed precision ball: 1.5748 O.D. 0.6692 I.D.
- Spindle nose: 3/4" - 16 (3/4" SAE)
- Spindle hole: 0.343
- Spindle ID taper: 15° (30° included)
- Max. collet diameter: 9/32"
- Pulley size: 5/8" bore

MICRO MILL

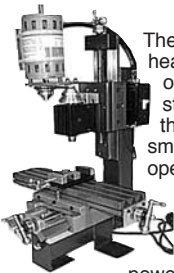

The Micro Mill has effortless, chatterless table and mill head movement. This is due to the unique design of our oversized gibs, ground steel ways, massive carriage, steel bed and vertical mill head support which makes the Micro Mill ready for CNC upgrade if you desire. Our small mill is really a scaled down big mill with manual operation. Other big mill features include large 0.001 graduations on friction adjustable micrometer dials for X, Y, and Z controls. Adjustable gibs provide full compensation for X, Y, and Z mill-ways wear. It all adds up to the best value in small mills. 15.5" table, power switch & cord included. Comes factory assembled.

2-yr. warranty.

P/N 12-00170\$617.00

General Specifications:

- | | Manual | CNC |
|-----------|---------|---------|
| • Height: | 21-3/8" | 26-3/8" |
| • Width: | 17" | 22" |
| • Depth: | 16.75" | 21" |
| • Weight: | 65 lbs. | 85 lbs. |
- Max. bearing run out: 0.0004"
 - Dovetails, X-axis: 45°; Y-axis: 90°

- Z-axis: Steel box-ways
- Pulley type: Std. 5/8" bore, multi-step V-belt
- Construction: steel, hard anodized aluminum on all moving components adjustable brass gibs and precision ground steel-ways.

Spindle Specifications:

- Maximum Spindle Speed: 7000 RPM
- Sealed Precision Ball Bearing: O.D.=1.5748, I.D.=0.6692
- Spindle Nose: 3/4" -16 (3/4" SAE)
- Spindle Hole: 0.343"
- Spindle ID taper: 15° (30° included)
- Max. Collet Diameter: 9/32"
- Pulley size: 5/8" bore

THE DISMANTLER™

Uniquely designed to solve your most difficult nut & bolt removal needs. Its compact, sturdy construction; standard and metric compatibility; high torque gear ratio; auto reverse feature and pass-through capability allow it to reach and work on hard to reach nuts and bolts in close quarters where standard wrenches are generally rendered useless. The Dismantler is a wrench that employs a worm gear to produce torque at a 20:1 turn ratio. Has a machined bronze gear set contained in compact, lightweight anodized aircraft aluminum housing. Weighs less than 4 lbs. Made of impact quality steel drive components so that it can be used with any electric or pneumatic impact wrench. Can also be manually driven with a simple ratchet. The Dismantler universally fits both standard (SAE) and metric sockets and has a through-hole feature that permits any length threaded rod or bolt to pass through the head of the tool. Made in USA. P/N 12-00492\$129.00

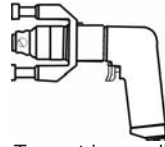

AT429SXC MICRO MILLER

The AT429SXC Micro Miller features a .75 horsepower 20,000 RPM Sioux Tools motor. Cutter capacity is 3/4" and the unit will cut steel, aluminum and stainless steel. Spindle size is 1/4"-28 and inlet pipe tap is 1/4" NPT. Air requirements: 90 PSI.

Tease trigger allows slow start up & exhaust porting is through the bottom of the handle. P/N AT429SXC\$428.95

Cutter Size	Cutter Dia.	Skirt Part No.	Skirt Price	Cutter Part No.	Cutter Price
-1	5/16	AT429A-1	\$20.50	AT429B-1	\$18.30
-2	3/8	AT429A-2	\$13.40	AT429B-2	\$16.50
-3	7/16	AT429A-3	\$20.70	AT429B-3	\$16.50
-4	1/2	AT429A-4	\$20.70	AT429B-4	\$18.30
-5	9/16	AT429A-5	\$13.40	AT429B-5	\$19.60
-6	5/8	AT429A-6	\$13.40	AT429B-6	\$16.50
-7	3/4	AT429A-7	\$13.40	AT429B-7	\$24.40

NICHOLSON HACKSAW BLADES

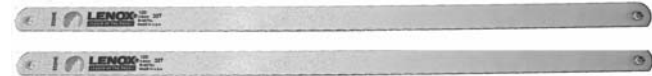

Nicholson Bi-Metaloy hacksaw blades last twice as long as high-speed steel and 10 times longer than carbon steel. Can operate 20%-50% faster. Practically unbreakable.

GENERAL RECOMMENDATIONS FOR BLADE SELECTION

- 14 TOOTH** - For cutting heavy cross section and for soft materials where maximum chip clearance is needed. P/N 12-19514\$2.35
- 18 TOOTH** - For general shop use, where blade is used on several jobs. P/N 12-19518\$1.96
- 24 TOOTH** - For cross sections of 1/16" to 1/4", such as pipe, angles, small drill rod. P/N 12-19524\$1.96
- 32 TOOTH** - For cutting stock up to 1/16" thick, such as 4130 tubing, sheet metal, BX. P/N 12-19532\$2.15

PLYWOOD PLANER-SCARFFER ATTACHMENT



The Plywood Planer-Scarffer attachment enables you to make consistent scarf cuts quickly and easily. Easy installation and removal allows your planer to be readily used for scarfing as well as a regular planer. The Planer-Scarffer attachment is easily installed on the Makitan 1900B, Makitan 1911B and the Porter Cable 9125 planers. The attachment is not limited to these particular models or makes. With the Planer-Scarffer attachment, you can purchase standard size sheets of plywood and then join them together. This saves the extra cost of larger sheets and the shipping charges that would be required. By scarfing 4x8 sheets together, save 60% or more in the price of the plywood and make the cost more bearable. The attachment is mounted on a power-planer and cuts an 8:1 bevel. 2 models are available. One fits a 4-3/8" planer for plywood up to 1/2". The other is designed for a 3-1/4" planer and can be used on plywood up to 3/8". Specify planer type when ordering. 3.25" attachment for Porter/Cable 9125P/N 12-20110-1900\$129.00 3.25" attachment for Makita n1900BP/N 12-20111-1911\$129.00

CRAFTSMAN WOOD TOOL CHEST



Build this magnificent wood tool chest from our detailed professional plan. It's the kind of chest a craftsman dreams of. Features 10 drawers in the sturdy base, 12 more drawers plus a large top bin in the removable upper section. Overall size is 25"W x 10-5/16"L x 27"H. Ideal for the aircraft builder or aircraft mechanic. Plans only for Wood Tool Chest. P/N 12-18350\$129.00

CRAFTSMAN WOOD TOOL CABINET PLANS



Machinist's and woodworkers show your skill. Impress potential customers when they come into your shop, and see such a nice cabinet like this. This cabinet has removable trays for easy access to all hand tools. This cabinet when built by my plans, will have room for all your hand tools. As a bonus it has wheels on it for easy mobility. Size of this unit when completed 32"W x 19"D x 68"H P/N 12-00978\$129.00

TO

TOOL KITS — METAL FORMING TOOLS



RV BUILDER TOOL KIT

These RV builders tool kits are based on recommendations from the Van's Aircraft Builders Manual as well as on the tools that have been purchased from Aircraft Spruce by RV builders. It is an

excellent tool kit for the construction of the RV4, 6, 7, 8, and 10 aircraft. They include an air drill, hand rivet squeezer, rivet sets and other tools of the highest quality. If you are building a RV-9 order 100 extra 3/32" clecos and 50 extra 1/8" clecos. If you are building a RV-10 kit, order 175 extra 3/32" clecos and 125 extra 1/8" clecos as well as the RV-10 bucking bar. See Chart Below for Components

Kit with 2x Rivet Gun P/N 12-00890 **\$2,320.27**
 Kit with 3x Rivet Gun P/N 12-00899 **\$2,338.17**
 RV-10 Bucking bar P/N 12-00903 **\$23.90**

BUILDER KIT COMPONENTS COMPLETE KIT

Part No.	Description	Price
2X	2X Rivet Gun	\$132.95
A1006-234X	RETAINER SPRING, BEEHIVE TYPE	\$8.00
A1007-234X	RETAINER SPRING, QUICK CHANGE	\$6.80
12-00869	AVERY PNEUMATIC AIR TOOL REG.	\$18.50
12-00816	AIR DRILL (PISTOL TYPE)4500RPM	\$225.95
12-00872	AVERY AIR TOOL OIL	\$5.10
12-00177	HAND RIVETING & DIMPLING TOOL	\$166.95
12-00605	AVERY POLY. DIMPLING MALLET	\$23.90
12-00320	3" YOKE FOR HAND RIVET SQUEEZER	\$78.00
12-00882	AVERY 6PC SQUEEZER SET	\$62.50
12-00868	AVERY DELUXE DIMPLE DIE KIT	\$228.95
12-00613	AVERY POP RIVET DIMPLER 3/32"	\$15.90
12-00611	AVERY VISE GRIP DIMPLER 3/32"	\$34.85
12-00887	AVERY #610 BUCKING BAR	\$20.30
12-00888	AVERY #615 BUCKING BAR	\$26.90
TP-670	BUCKING BAR 1-3/4 LB.	\$18.30
SM10-4704	STRAIGHT RIVET SET 1/8X 3-1/2	\$6.25
12-00873	AVERY 1/8" DBL OFFSET RIVET ST	\$28.20
12-00741	AVERY FLUSH SWIVEL RIVET SET	\$46.30
12-07100-3	AVERY BACK RIVET SET 4-1/8"L	\$21.80
12-00609	AVERY FLUTING PLIER	\$32.90
12-00608	AVERY HAND SEAMER 3-1/2" JAW	\$34.40
12-10105	CLECO PLIERS	\$5.40
M-3/32	SHEET HOLDERS M-3/32 KWIK-LOK	\$0.43
M-1/8	SHEET HOLDERS M-1/8 KWIK-LOK	\$0.43
M-5/32	SHEET HOLDERS M-5/32 KWIK-LOK	\$0.43
M-3/16	SHEET HOLDERS M-3/16 KWIK-LOK	\$0.43
SC-1/2-1/2	1/2" X 1/2" SIDE GRIP CLAMP	\$2.80
SC-1/2-1	SIDE GRIP CLAMPS P/N SC-1/2-1	\$2.25
12-00632	AVERY EDGE ROLLING TOOL	\$17.95
12-00618	AVERY BACK RIVETING PLATE	\$39.90
12-00876	AVERY CUT/POLISH WHEEL KIT	\$49.90
12-03900	UNIBIT STEP DRILL # 3	\$29.95
12-18355	RIVET TAPE 3/4" GREEN	\$6.00
12-04214	#40 SUPER COBALT DRILL (4PACK)	\$0.95
12-04217	SUPER COBALT DRILL #30 (3PACK)	\$1.35
12-14221	SUPER COBALT DRILL #21 (3PACK)	\$1.59
12-04219	SUPER COBALT DRILL #27 (3PACK)	\$1.51
12-00886	AVERY #19 COBALT DRILL BIT 2PK	\$4.90
12-00885	AVERY #12 COBALT DRILL BIT 2PK	\$6.40
12-00884	AVERY 1/4" COBALT DRILL BIT	\$4.35
12-05200	DRILL BITS 12" LONG 3/32"	\$3.95
12-05300	DRILL BITS 12" LONG 1/8"	\$4.75
12-00867	AVERY 4PC DRILL STOP SET	\$13.30
12-00883	AVERY 90° ANGLE DRILL KIT	\$176.95
12-01412	AVERY MICRO-STOP CSNK CAGE	\$38.50
12-00879	AVERY #40 X 3/8" CSNK CUTTER	\$12.80
12-00880	AVERY #30 X 3/8 CSNK CUTTER	\$12.80
12-00881	AVERY #20 X 1/2" CSNK CUTTER	\$12.90
12-00874	AVERY 3PK PILOT PENS	\$6.95
1216	STEEL RULES #1216	\$7.20
12-00631	AVERY SHOP HD RIVET GAUGE SET	\$16.00
12-00633	AVERY RIVET LENGTH GAUGE	\$6.90
M-1R	WISS SNIPS # M-1R	\$17.85
M-2R	WISS SNIPS # M-2R	\$17.85
12-00622	AVERY SPEED DEBURR-CSINK TOOL	\$26.00
12-00877	AVERY ROYAL MULTI-BURR TOOL	\$21.80
12-00629	AVERY DOUBLE EDGE DEBURR TOOL	\$14.85
12-00875	AVERY SCOTCHBRITE CUT/PLSH WHL	\$61.00
01-00392	CURVED TOOTH FILE 14" LONG	\$54.95
12-00870	AVERY 3/32" DRIVE PIN PUNCH	\$6.40
12-00871	AVERY 1/8" DRIVE PIN PUNCH	\$6.40
12-00889	AVERY 360DEG SWIVEL POP RVT TL	\$41.00
13-19205	JEPP ACFT SHT METAL & EA SM	\$18.95
13-11400	STANDARD AIRCRAFT HANDBOOK	\$23.95



KIT BUILDER AIRCRAFT TOOL KIT

Initially designed for the RV3, RV4 and RV6 builders, this kit has proven to be very popular with virtually all aircraft home builders. It contains our most popular rivet hammer and is an excellent tool kit for RV builders. Weight: 40 lbs.

This 530 piece kit includes:

- 1 TP1112 - Bucking Bar
- 1 TP647 - Bucking Bar
- 1 TP74 - Cleco Pliers
- 1 TP266 - Deburring Tool
- 1 TP97 - Air Tool Regulator
- 1 TP4263 - Dimple & Die Set
- 1 116A - Squeezer Set mix
- 1 TP61 - Micro Stop Countersink
- 1 TP91 - Flush Rivet Set w/Rubber Guard
- 1 TP89 Straight Rivet Set (5 Pcs. SM10 Series)
- 1 TP83 Standard or TP84 (special order) Rivet Gun (specify)
- 1 TP88 - Beehive & Quick Change Retainer Springs
- 1 TP90- 10° Offset Rivet Sets (5 Pcs., SM20 Series)
- 3 TP62 - Countersink Cutter Pilots (1 ea.: TP62-21, TP62-30, TP62-40)
- 500 TP75 - Cleco Fasteners (325 pcs. TP75-3/32 & 175 pcs. TP75-1/8)
- 1 TP44 - Hand Seamer
- 1 TP638 - Bucking Bar
- 1 TP116 - Hand Rivet Squeezer
- 1 TP670 - Bucking Bar
- 1 TP162 - Fluting Pliers
- 1 TP216 - Tool Box w/Tote Tray
- 1 TP96 - Rivet Cutter
- 1 TP4264 - Dimple & Die Set
- 1 TP45 - 1/4" Air Drill

P/N TP176RV **\$633.00**

WHEELING MACHINE (BENCH MODEL)



An affordable entry level machine with a 22" deep throat. Comes with one lower anvil wheel (2.375) and can be bench mounted or clamped in a vise. Shown with optional stand anvil wheels.

P/N 12-00571 **\$592.00**
 Optional stand P/N 12-00575 **\$187.95**

WHEELING MACHINE (U-WELD MODEL)



This floor model machine is available in Kit Form. We supply: upper wheel, yoke, anvil wheels, screw lift assembly, kick wheel adjuster, quick release cam, steel casters & instructions. You supply steel tubing for frame. P/N 12-00570 **\$1,590.00**

BEATER BAG



18" diameter; Double stitched; Can be filled with lead shot or sand. P/N 12-00574 **\$47.70**
 Optional Anvil Wheels

3.25" P/N 12-00576 **\$85.00**
 5.00" P/N 12-00577 **\$85.00**
 8.50" P/N 12-00578 **\$85.00**

AMAZING ROD SAW

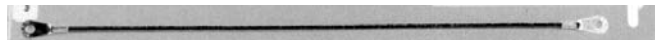

Tiny particles of tungsten carbide, one of the toughest and hardest substances in the world, have been bonded to a steel rod to produce the Rod Saw. Fits standard 12" hacksaw frame. Use when regular hacksaw will not work. Lets you cut steel, rock. Not recommended for soft materials. P/N DT-12V **\$6.70**

TO

TOOL KITS



MASTER KIT BUILDERS KIT

The Master Kit Builders Kit (TP176MKB) contains all the tools supplied in the "RV" tool kit plus many more. It is designed to supply all the major, most commonly used tools for the building sheet metal aircraft. These items can be used on RV's, Zenair, Questair and Mustang Aeronautic Kits as well as many, many others. A huge savings can be realized by purchasing this kit over the individual tool price. Wt. 50 lbs.

P/N TP176MKB\$754.00

Kit Contains:

- 1 - TP83 or TP84 Rivet Gun (specify)
- 1 - TP89i - Straight Rivet Set (5 pcs., SM10 series)
- 1 - TP90i - 10° Offset Rivet Sets (5 pcs., SM20 series)
- 1 - TP91i - Flush Rivet Set with Rubber Guard
- 1 - TP88 - Beehive & Quick Change Retainer Springs
- 1 - TP97 - Air Tool Regulator
- 1 - TP96 Rivet Cutter
- 1 - TP45 - 3/8" Air Drill
- 1 - TP162 - Fluting Pliers
- 1 - TP61 - Micro Stop Countersink
- 3 - TP62 - Countersink Cutter Pilots (1 ea.: TP62-21, TP62-30, TP62-40)
- 500 - TP75 - Cleco Fasteners (325 pcs. TP75-3/32 & 175 pcs. TP75-1/8)
- 1 - TP74 Cleco Pliers
- 1 - TP44 - Hand Seamer
- 1 - TP266 - Deburring Tool
- 1 - TP638 - Bucking Bar
- 1 - TP647 - Bucking Bar
- 1 - TP670 - Bucking Bar
- 1 - TP1112 - Bucking Bar
- 1 - TP51 - Aviation Snip - Right
- 1 - TP52 - Aviation Snip - Left
- 1 - TP53 - Aviation Snip - Straight
- 1 - TP844 - Hand Blind Riveter
- 1 - TP636 - 1/8" Pop Dimple Die Set
- 6 - TP49-40 - Drill Bit
- 4 - TP49-30 - Drill Bit
- 2 - TP49-12 - Drill Bit
- 1 - TP49-1/4 - Drill Bit
- 4 - TP145DS - Drill Stops (#40, #30, #12, 1/4)
- 1 - TP312 - Circle Hole Cutter
- 1 - TP116 - Hand Rivet Squeezer
- 1 - TP116A Rivet Sets for TP116 (2 Flush & 4 Universal Head)
- 1 - TP4263 - 3/32" Dimple Die Set
- 1 - TP4264 - 1/8" Dimple Die Set
- 1 - TP722 - Fluting Plier (small Flute)
- 1 - TP260 2 Drawer Tool Box (US902 pneumatic Cleco installation tool is optional, but recommended)

MASTER AIRCRAFT TOOL KIT



This 121-piece complete Aircraft mechanics Kit is excellent for aircraft restoration, repair and manufacturing. It is ideal for the A & P mechanic, student and homebuilder. Kit comes with everything from sheet metal tools to riveting tools in a two-drawer tool chest. This kit includes the top quality riveting hammer manufactured in the U.S.A. Wt. 48 lbs.

P/N TP176M\$827.00

Kit Contains:

- 1 - TP83 / TP84 3X or 4X Offset Handle Rivet Gun
- 40 - TP75 - Cleco Fasteners (10 ea.: 3/32", 1/8", 5/32" & 3/16")
- 20 - TP109M - Wing Nut Fasteners (5 ea.: 3/32", 1/8", 5/32" & 3/16")
- 4 - TP145DSK - Drill Stop Kit (1 ea.: #21, #30, #40 & #10)
- 3 - TP62 - Replaceable Pilots (1 ea.: #21, #30 & #40)
- 3 - TP54 - Threaded Drill Bits (1 ea.: #21, #30 & #40)
- 2 - TP88 - Spring Retainer Set
- 5 - TP89i - Straight Rivet Set Mix
- 5 - TP90i - Offset Rivet Set Mix
- 1 - TP91i - Flush Set with Guard
- 1 - TP638 - Bucking Bar
- 1 - TP1112 - Bucking Bar
- 1 - TP670 - Bucking Bar
- 1 - TP647 - Bucking Bar
- 1 - TP97 - Air Tool Regulator
- 1 - TP51 - Aviation Snip - Left
- 1 - TP52 - Aviation Snip - Right
- 1 - TP52 - Aviation Snip - Right
- 1 - TP53 - Aviation Snip - Straight
- 1 - TP61 - Stop Countersink
- 1 - TP45 - 3/8" Pistol Grip Air Drill
- 1 - TP46 - 90° Angle Attachment
- 1 - TP346 - Heavy Duty Rivet Cutter
- 1 - TP116 - Hand Rivet Squeezer
- 6 - TP116A - Squeezer Set Mix
- 1 - TP74 - Cleco Pliers
- 1 - TPMM250-1 - Strap Duplicator #40
- 1 - TPMM250-2 - Strap Duplicator #30
- 1 - TPMM250-3 - Strap Duplicator #21
- 1 - TPMM250-5 - Strap Duplicator #10
- 1 - TP57 - Cone Jaw Chuck
- 1 - TP162 - Fluting Pliers
- 1 - TP76K - Hand Punch Kit
- 1 - TP44 - Hand Seamer
- 1 - TP81 - Hand Nibbler
- 1 - TP206 - Aircraft Repair Manual
- 1 - TP260 - 2-Drawer Tool Chest
- 5 - TP123SG - Side Grip Fasteners
- 1 - TP70 - Chip Chaser
- 1 - TP675 - Air Vacuum



DELUXE STUDENT TOOL KIT

This kit meets most school requirements for basic sheet metal tools. These high quality tools will take the student through school and into the profession for years of outstanding service. It contains the most popular rivet hammer and is a great starter kit. Wt. 14 lbs.

P/N TP176ST\$435.95

Kit Contains:

- 1 - TP83 - Rivet Hammer
- 1 - TP2012 - Deluxe Air Tool Regulator
- 1 - A1006-234X - Beehive Spring Retainer
- 1 - A1007-234X - Quick Change Spring Retainer
- 1 - TP89 - 5 Pc. Straight Rivet Set Mix (AN470)
- 1 - TP670 - Bucking Bar
- 1 - TP346 - Rivet Cutter
- 40 - TP74 - Cleco Fasteners (10.: 3/32" 1/8", 5/32", 3/16")
- 1 - TP45 - 3/8" Air Drill
- 6 - TP49 - Drill Bits
- 1 - TP145DSK - 4 Pc. Drill Stop Kit
- 1 - TP61K - Micro Stop Countersink and 3 Cutters
- 1 - TP279 - Military Style Tool Pouch

GLASTAR TOOL KIT



This kit is designed for all new Glastar kit aircraft. The tools included are recommended by the manufacturer, specifically for the assembly of the sheet metal portion of the kit. Many of these tools are of top quality, and designed to last. They are all covered by a 30 day unconditional money back guarantee.

P/N TP176G\$815.00

Kit Contains:

- 1 - SM10-4706i - 3/16" Universal Rivet Set
- 1 - TP83 - Offset Handle Rivet Gun
- 1 - SM10-4703i - 3/32 Universal Rivet Set
- 1 - SM10-4704i - 1/8 Universal Rivet Set
- 1 - TP91 - Flush Set w/rubber guard
- 1 - A1007-234X - Quick Change Retainer Spring
- 1 - TP61 - Stop Countersink
- 1 ea. - TP62 - 100° Countersink Cutter Pilots (12, 21, 30 & 40)
- 1 ea. - TP62A - 120° Countersink Cutter Pilots (30)
- 1 - TP116 - Hand Rivet Squeezer
- 1 - TP4263SB - 1/8 Dimple Die Set
- 1 - TP4264SB - 3/32 Dimple Die Set
- 1 - TP45 - 3/8" Capacity Air Drill
- 250 - TP75 - 3/32 - 3/32 Cleco Fasteners
- 150 - TP75 - 1/8 - 1/8 Cleco Fasteners
- 25 - TP75 - 3/16 - 3/16 Cleco Fasteners
- 1 - TP74 - Cleco Plier
- 1 - TP266 - Deburring Tool w/blades
- 1 - TP838 90° Countersink/ Deburring Set
- 1 - TP216 - Tool Box
- 1 ea. - TP638, TP721, TP760B - Bucking Bars
- 1 ea. - TP49-11/64, 1/4, 1/16 - Assorted Jobber Drill Bits
- 1 - TP249 - 60 pcs. - #1-#60 Jobber Drill Bit Set
- 1 ea. - TP55-30, 40 - 6" Aircraft Extension Bits
- 1 - TP55A-40 - 12" Side Grip Clamps
- 2 - TP538STC - Tension Clamp
- 1 - TP51K - Aviation Snip Kit - Left, Right, Straight
- 1 - TP46K - 90° Drill Attachment with Bits #40, #30, #21
- 1 - TP70 - Chip Chaser
- 1 - TP844 - Swivel Hand Riveter
- 1 - TPA5588 - Hook Scriber
- 1 - TP294AP - Center Punch
- 1 - BG383-1 - Tape Measure
- 1 - TP604B - 12" Ruler 32nds, 64ths, 10ths, 100ths, Graduations
- 1 - TP297 - Spring Divider (Caliper)

MUSTANG TOOL KIT



This kit is designed especially for the assembly of the Mustang Kit aircraft. It is comprised of over 300 items, specifically required in the fabrication and assembly of this aircraft. Contains one of the most popular rivet guns, TP83 or TP84, which features: • Precision machined hardened and ground valve • Sure Grip powder coated finish • Teasing trigger • Precision machined and hardened cylinder for long life • Weight: 34 lbs.

Kit w/ TP83 gunP/N 12-00347\$677.00
 Kit w/ TP84 gunP/N 12-00498\$677.00

RIVETING HAMMERS



US 3X

RIVETING HAMMERS

These high quality riveting hammers are excellent for all light aircraft metal riveting applications. They feature a convenient offset handle (except Model US3AA which is straight handle) and come complete with retainer spring and regulator. Used for .401 shank diameter (except Models US5X, US9X, and US7X which use .498). All models except USAVC12, USAVC13, USE3, and USE5 feature metered teasing throttle, made in U.S.A

Part No.	Blows / Min.	Capacity Alum.	Bore	Stroke	Length	Weight (Lbs.)	Price
US1X	3600	1/8"	9/16"	1-1/2"	5-11/16"	2	\$223.95
US2X	2580	1/8"	1/2"	2-1/4"	6-11/16"	2-1/4	\$200.95
US3X	2160	3/16"	1/2"	2-7/8"	7-5/16"	2-5/16	\$205.95
US5X	1560	1/4"	3/4"	2-11/16"	6-11/16"	4-3/4	\$449.95
US7X	900	3/8"	3/4"	5-13/16"	8-5/16"	6	\$356.95

"RECOILLESS" RIVETING HAMMERS



US 3R

In the early stages of developing a truly recoilless/fatigueless riveting hammer, it was determined that the tools must meet certain goals. The main goal being a reduction in low-frequency vibration in accordance with ISO Standard #5349-1986. In this standard are guidelines for the measurement and assessment of human exposure to hand-transmitted vibration. As a result, the following has been achieved: •Ergonomic design: To maximize user comfort by achieving a relaxing, comfortable, lightweight and balanced tool •Compact tool size: Since aircraft riveting is never standard, a tool that will allow the best overall access • Retain user touch: A metered trigger which provides single or multiple blows per minute while maintaining the ability to set rivets in seconds • Further dampen noise output. • Least amount of parts: No similar tool is produced with fewer parts, thus enhancing reliability, but keeping it simple enough so that maintenance can be done by anyone.

Independent testing* has shown these tools will greatly lessen job-related effects of prolonged exposure to vibration & boost user productivity.

SPECIFICATIONS

Part No.	Capacity		Bore	Stroke	Blows per minute
	Alum.	Steel			
US3R	3/16"	5/32"	1/2"	3"	1900
US5R	1/4"	3/16"	1/2"	5"	1400

Part No.	Rivet Set dia	Overall Length	Weight	Air Inlet	Price
US3R	.401	7-7/8"	3 Lbs.	1/4 NPT	\$274.95
US5R	.401	9-7/8"	3.5 Lbs.	1/4 NPT	\$265.95

PNEUMATIC RIVET SQUEEZER



Heavy duty industrial tools are manufactured to exacting standards to insure long service life. All critical parts, including the yoke, are fabricated from 4130 steel and heat treated to Rc 42-46. These rivet squeezers have earned a reputation for durability and reliability through years of service on the production lines of major airframe manufacturers such as Grumman, Piper, Beech and Cessna. Easily operated by one hand. All replacement parts and other yoke designs available. Features feathering throttle.

	Model 3000	Model 6000
Power	3000 Lbs.	6000 Lbs.
Rivet Capacity	Dural1/8"3/16"	Steel1/8"5/32"
Standard Yoke Reach	2-1/2"	2"
Air Hose Size	1/4"	1/4"
Set Travel	9/16"	9/16"
Recommended Line Pressure	90 PSI	90 PSI
Weight	4-1/2 Lbs.	6 Lbs.
Part Number	12-03400	12-03500
Price	\$589.00	\$688.00

ECONOMY RIVET GUNS



The standard tool used in aircraft manufacturing plants such as Boeing, Rockwell, Lockheed etc., is completely interchangeable with Chicago Pneumatic. These tools are slow hitting with excellent finger tip control. Accepts all .401 shank rivet sets and attachments. All guns are brand new and carry a full 1 year warranty.

Part No.	Blows / Min.	Capacity Alum.	Bore	Stroke	Weight (Lbs.)	Price
2X	2580	1/8"	1/2"	2-1/4"	2.7	\$132.95
3X	2160	3/16"	1/2"	2-7/8"	3.4	\$141.95
4X	1740	1/4"	1/2"	3-1/16"	3.6	\$121.95

TP176 RIVET GUN KITS



This kit provides all the essentials for straight and offset riveting. Four of the most commonly used bucking bars; 8 cupped sets for 3/32", 1/8", 3/16" AN470 universal head rivets; 3 flush sets for AN426 rivets; 2 retainer springs; an air regulator for adjusting hammer blows; tool oil; an attractive molded rubber case for organization and storage; and a 4X or 3X rivet gun. Ideal for structural and sheet-metal technicians, home builders, & students.

TP176-4X kitP/N AT590RGK-4X\$318.95
TP176-3X kitP/N 12-00240\$299.95

SPECIAL DIMPLING & RIVET SET

FOR RV4, RV6, RV8 AIRCRAFT



This 21-piece dimpling and riveting set was designed especially for use in the construction of the Vans RV aircraft series, and is ideal for a variety of other aircraft as well. All the riveting sets and dimple dies are made from heat treated stainless steel.

* Dimple dies size stainless steel - rivet set are steel. All are heat treated.

SPECIAL RV DIMPLING AND RIVETING KIT INCLUDES:

Set holder block, Cup sets, Flat sets, and Spring back dimple dies.
Dimple Dies - 3/32", 1/8", 5/32" rivet size. 6-32, 8-32, 10-32 screw sizes.
Cup Sets - 3/32", 1/8", 5/32".
Flat Sets - 1/16", 1/8", 3/16", 1/4", 5/16", 3/8", 1/2". Polyethylene set.
 21-piece kit.....P/N 12-00450.....\$205.95



7-PC RIVET SET

Holder includes 3/32", 1/8", 5/32 and 3/16 cups for AN470 rivets, plus 3 flat sets for AN426 rivets. To be used with pneumatic or hand rivet squeezer.
 P/N 12-00555\$108.95



6-PC DIMPLE DIE SET RIVET SIZE

Holder includes springback dimple dies for 3/32", 1/8" and 5/32" rivets. To be used with pneumatic or hand rivet squeezer.
 P/N 12-00560\$104.95



6-PC DIMPLE DIE SET SCREW SIZE

Holder includes springback dimple dies for 6-32, 8-32 and 10-32 screw sizes. To be used with pneumatic or hand rivet squeezer.
 P/N 12-00565\$103.95

RIVET SETS FOR RIVETING HAMMERS

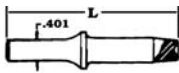

RIVET SETS STRAIGHT .401 SHANK (AN470)

Length "L"	Part Numbers					Price
	Rivet Size 3/32"	Rivet Size 1/8"	Rivet Size 5/32"	Rivet Size 3/16"	Rivet Size 1/4"	
3-1/2"	SM10-4703	SM10-4704	SM10-4705	SM10-4706	SM10-4708	\$6.10
5-1/2"	SM11-4703	SM11-4704	SM11-4705	SM11-4706	SM11-4708	\$8.20
7-1/2"	SM12-4703	SM12-4704	SM12-4705	SM12-4706	SM12-4708	\$8.80
10-1/2"	SM13-4703	SM13-4704	SM13-4705	SM13-4706	SM13-4708	\$14.20

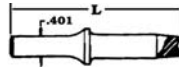

RIVET SETS STRAIGHT .498 SHANK (AN470)

Length "L"	Part Numbers					Price
	Rivet Size 3/32"	Rivet Size 1/8"	Rivet Size 5/32"	Rivet Size 3/16"	Rivet Size 1/4"	
3-1/2"	SM30-4703	SM30-4704	SM30-4705	SM30-4706	SM30-4708	\$12.90
5-1/2"	SM31-4703	SM31-4704	SM31-4705	SM31-4706	SM31-4708	\$19.00
7-1/2"	SM32-4703	SM32-4704	SM32-4705	SM32-4706	SM32-4708	\$16.20

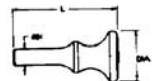

FLUSH SETS STRAIGHT .401 SHANK (AN470)

Dia.	Length	P/N	Price	Dia.	Length	P/N	Price
1"	2-1/2"	SM90	\$9.35	1-1/2"	5-1/2"	SM95	\$15.70
1"	3"	SM91	\$13.90	1-1/2"	3-1/8"	SM96	\$15.70
1"	5-1/2"	SM92	\$14.70	1-3/4"	3-1/4"	SM97	\$18.50
1"	7-1/2"	SM93	\$17.00	1-1/8"	2-1/4"	SM98	\$18.80
1-1/4"	3"	SM94	\$15.95	1-1/4"	2-1/4"	SM99	\$17.90

NOTE: These flush sets are universal for any diameter rivet. Order by part number referencing the length and diameter of the flush set required.

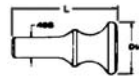

FLUSH SETS STRAIGHT .498 SHANK (AN470)

Dia.	Length	P/N	Price	Dia.	Length	P/N	Price
1"	2-1/2"	SM100	\$15.95	1-1/2"	3-1/8"	SM106	\$16.80
1"	3"	SM101	\$14.10	1-3/4"	3-1/4"	SM107	\$18.20
1"	5-1/2"	SM102	\$13.70	1-1/8"	2-1/4"	SM108	\$22.50
1"	7-1/2"	SM103	\$18.95	1-1/4"	2-1/4"	SM109	\$22.95
1-1/2"	3"	SM104	\$19.75				

NOTE: These flush sets are universal for any diameter rivet. Order by part number referencing the length and diameter of the flush set required.

SETS FOR HIGH SHEAR RIVETS .401 SHANK



Length on all is 3-1/2"

Rivet Size	Part No.	Price
1/8"	SMHS10-4	\$15.95
5/32"	SMHS10-5	\$16.75
3/16"	SMHS10-6	\$17.30
1/4"	SMHS10-8	\$15.95

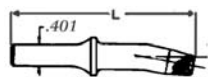

RIVET SETS OFFSET .401 SHANK (AN470)

Length "L"	Part Numbers					Price
	Rivet Size 3/32"	Rivet Size 1/8"	Rivet Size 5/32"	Rivet Size 3/16"	Rivet Size 1/4"	
3-1/2"	SM20-4703	SM20-4704	SM20-4705	SM20-4706	SM20-4708	\$7.10
5-1/2"	SM21-4703	SM21-4704	SM21-4705	SM21-4706	SM21-4708	\$7.40
7-1/2"	SM22-4703	SM22-4704	SM22-4705	SM22-4706	SM22-4708	\$11.40
10-1/2"	SM23-4703	SM23-4704	SM23-4705	SM23-4706	SM23-4708	\$17.90

FLUSH SETS OFFSET .401 SHANK (AN470)

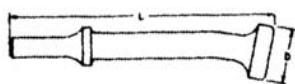

DIA	Length	P/N	Price
1"	3-1/2"	SM140	\$16.30
1"	7-1/2"	SM142	\$19.50
1"	5-1/2"	SM141	\$16.30

NOTE: These flush sets are universal for any diameter rivet. Order by part number referencing the length and diameter of the flush set required.

BUCKING BLOCKS

Designed to be used with a riveting gun or by striking with a hammer. For aid with dimpling and/or riveting applications. Acts as a holding fixture for .187 shank dimple dies or rivet sets. Weight: 4 lbs.

P/N TP93\$31.60



SWIVEL DIMPLING TOOL .401 Shank

*Can be used with TP93 Bucking Block

***Example: To order L = 3-1/2" - 1/8" Rivet specify: SM10SP-4264

MODEL #	"L"	TYPE	PRICE
SM10SP***	3-1/2"	Punch	\$43.80
SM10SD	3-1/2"	Die	\$39.30

CUPPINGS	3/32	1/8	5/32	3/16
For 100° Rivets (AN426)	4263	4264	4265	4266

KNOCKOUT PUNCHES FOR HIGH SHEAR RIVETS .401 SHANK

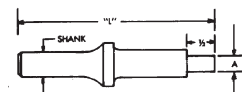

Length on all is 3-3/8"

RIVET SIZE	PART NO.	PRICE
1/8"	SMHS401K-4	\$10.40
5/32"	SMHS401K-5	\$8.90
3/16"	SMHS401K-6	\$8.90
1/4"	SMHS401K-8	\$8.90

.401 SHANK RIVETING HAMMER ACCESSORIES

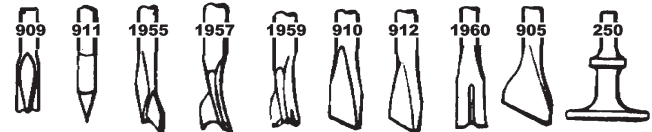

DESCRIPTION	P/N	PRICE	DESCRIPTION	P/N	PRICE
Twin Blade Cutter	909	\$10.60	Chisel	910	\$8.90
Moil Point	911	\$9.00	Rivet Buster	912	\$13.80
Body Ripper	1955	\$10.60	Spotweld Breaker	1960	\$10.20
Panel Cutter	1957	\$10.50	Scraper	905	\$11.80
Metal Trimmer	1959	\$10.90	Flush Set	SM97	\$18.50

RETAINER SPRINGS

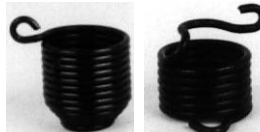

Retainer springs comes in two styles: Quick Change Type: Designed to make possible speedy changing of rivet set in rivet gun. Beehive Type: Designed as a fixed type to securely hold rivet set in rivet gun.

Beehive Type Quick Change

RIVET HAMMER	BEEHIVE TYPE		QUICK CHANGE TYPE		
	MODEL #	P/N	PRICE EA.	P/N	PRICE EA.
1X-2X-3X-4X	A1006-234X		\$8.00	A1007-234X	\$6.90
5X-7X-9X	A1006-579X		\$5.90	A1007-100B	\$9.00
E3-E5	A1006-234X		\$8.00	A1007-AVC	\$6.90
100B-200B				A1007-234X	\$6.90
AVC12-AVC13	A1006-AVC		\$6.80		
3R-5R	A1006-234X		\$8.00		

RIVET SET HOLDER



This "no mar" rivet set holder was developed by an RV-7 builder who needed to drive rivets in tight spaces without scratching the surrounding metal, such as happens when using standard metal spring type set holders. Just attach the holder to a recessed (mushroom) rivet set, backside rivet sets, or any other rivet too set. A small slit in the half inch hole allows the set holder to stretch over the shoulder of the recessed and backside tools. P/N 12-01391.....\$2.85









BACK RIVETING RIVET SET

For back riveting flush rivets on RV control surfaces and other homebuilts. Has a plastic Delrin sleeve with spring to hold multiple sheets of aluminum together while riveting. 0.401 shank x 4-1/8 inches long. Back Rivet Set 3-1/2" long.....P/N 12-07100-3.....\$21.80 ea.

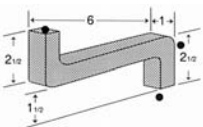
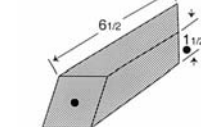
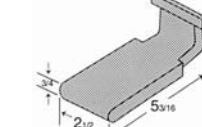
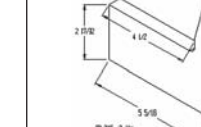
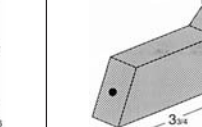
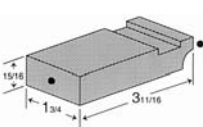
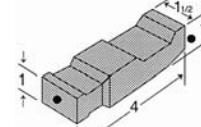
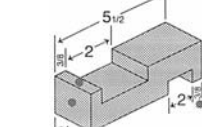
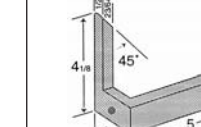
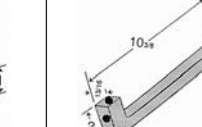
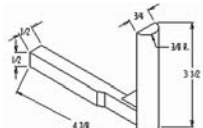
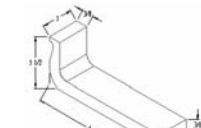
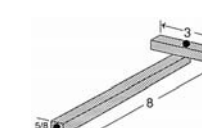
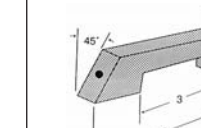
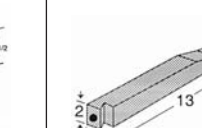
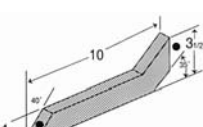
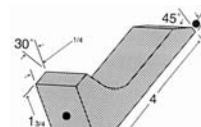
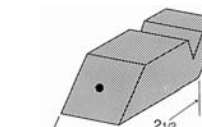
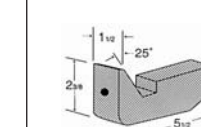
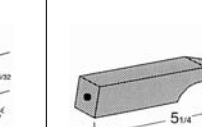
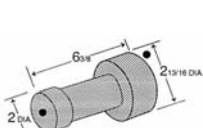
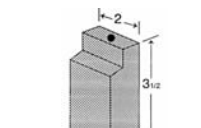
TO

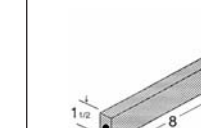
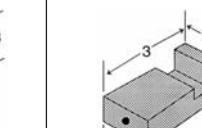
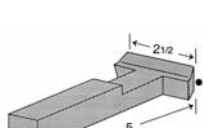
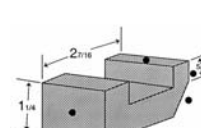
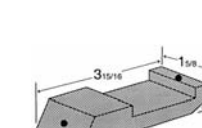
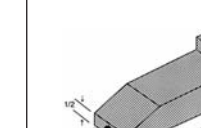
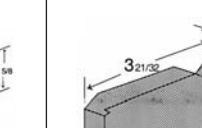
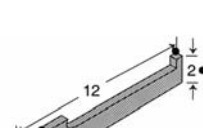
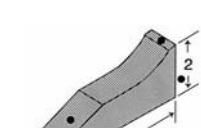
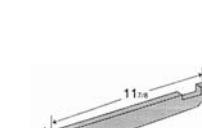
BUCKING BARS

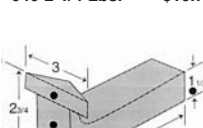
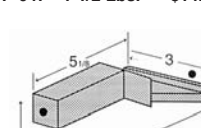
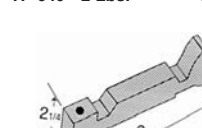
Our bucking bars are cast with ductile iron to insure non-porous finish which is very important in order to have a highly polished finished surface. They are heat treated to 38-42 RC and therefore can be repolished many times without changing hardness. This wide selection of sizes, shapes, and weights enables the aircraft builder to pick the proper bar for his job. Made in the U.S.A.

 <p>TP-690 - 2-3/4 Lbs. \$14.50</p>	 <p>TP-692 - 3 Lbs. \$14.40</p>	 <p>TP-701 - 3 Lbs. \$14.70</p>	 <p>TP-715 - 2 Lbs. \$14.30</p>	 <p>TP-721 - 1-3/4 Lbs. \$32.80</p>
 <p>TP-723 - 1-1/2 Lbs. \$14.70</p>	 <p>TP-730 - 1-1/4 Lbs. \$13.60</p>	 <p>TP-736 - 2-3/8 Lbs. \$27.40</p>	 <p>TP-750V-1 1-1/4 Lbs. \$14.60</p>	 <p>TP-751 - 3-5/16 Lbs. \$24.90</p>
 <p>TP-751V-1 - 1-1/4 Lbs. \$14.70</p>	 <p>TP-752P-1 - 1/2 Lbs. \$14.70</p>	 <p>TP-753 - 1-1/2 Lbs. \$29.30</p>	 <p>TP-760B-1 - 1 Lb. \$10.80</p>	 <p>TP-683 - 3-1/4 Lbs. \$14.30</p>
 <p>TP-760C-1 - 1-3/4 Lbs. \$14.70</p>	 <p>TP-763 - 2-1/2 Lbs. \$19.60</p>	 <p>TP-1090 - 1-3/8 Lbs. \$14.40</p>	 <p>TP-1111 - 3 Lbs. \$11.30</p>	 <p>TP-1112 - 1-3/8 Lbs. \$20.80</p>
 <p>TP-601 - 6 Lbs. \$31.50</p>	 <p>TP-605 - 1-1/2 Lbs. \$15.20</p>	 <p>TP-610 - 3/4 Lb. \$14.20</p>	 <p>TP-614 - 2-3/4 Lbs. \$14.50</p>	 <p>TP-619 - 1-1/4 Lbs. \$11.50</p>
 <p>TP-633 - 1-1/4 Lbs. \$14.30</p>	 <p>TP-634 - 1 Lb. \$14.50</p>	 <p>TP-638 - 1-1/4 Lbs. \$17.80</p>	 <p>TP-639 - 2 Lbs. \$14.30</p>	 <p>TP-643 - 1-1/4 Lbs. \$14.50</p>
 <p>TP-646 2-1/4 Lbs. \$10.70</p>	 <p>TP-647 - 1-1/2 Lbs. \$14.20</p>	 <p>TP-649 - 2 Lbs. \$14.50</p>	 <p>AT-618 - 2-1/4 Lbs. \$34.00</p>	 <p>TP-662 - 1 Lb. \$11.50</p>
 <p>TP-667 - 4-1/4 Lbs. \$21.90</p>	 <p>TP-669 - 1-3/8 Lbs. \$13.70</p>	 <p>TP-670 - 1-3/4 Lbs. \$18.30</p>	 <p>TP-671 - 2-1/4 Lbs. \$38.90</p>	 <p>TP-683 3-1/4 Lbs. \$14.30</p>

TO

RIVET TOOLS – SHEARS



RIVET REMOVAL TOOL

This quality tool enables the user to quickly and accurately remove rivets and blind fasteners. The tool comes complete with drill bits and guides, #40, #30, #21, and #10. Made in U.S.A.

REPLACEMENT BITS

P/N TP-5410L	\$3.45	P/N TP-5430L	\$2.30
P/N TP-5421L	\$2.35	P/N TP-5440L	\$2.60

P/N TP-276.....\$88.25

HAND RIVETING & DIMPLING TOOL



Used for hand dimpling of skins and small parts and for hand riveting of parts, assemblies, and spars. This tool maintains alignment of the dies to each other, and insures proper alignment to the work surface for superior dimpling results over either rivet gun or free-hand dimpling methods.

Features include: • 22" deep x 4" tall throat • Heavy wall 1" x 2" steel tube arm • Heavy wall aluminum channel base • Bronze 1/2"

I.D. guide bushings for shafts • Heat treated and centerless ground stainless steel driver shaft (2)—one shaft has flat end for riveting with rivet gun & one shaft accepts 0.187" shanks for dimple dies & sets. • 1.5" extension shaft for dies • Adjustable die holder block. Rivet Tool Return Spring Kit now included (Spring, collar and wrench). Great for one handed dimpling of skins and parts. Uses rivet, dimple and die sets with .187" shank. (Dies and sets sold separately)

P/N 12-00177\$166.95

DRDT-2 RIVET DIMPLER



DRDT-2 (AKA Dash 2) is a welded steel c-frame rivet dimpler. Replaces the common impact c-frame rivet dimplers of the past. With its ample mechanical advantage, dimpling is fast, easy, less fatiguing and safe on the skins. With a fully adjustable set holder you can achieve consistent and accurate dimples. The DRDT-2 incorporates a new low force spring return system that prevents skin damage from the accidental release of the handle without increasing the force required to dimple. 22" throat depth allows dimpling of up to 44" wide sheets. The relief under the lower frame member provides dimpling access to spars, ribs, leading edge skins. Designed and analyzed using state of the art engineering tools the DRDT-2 can handle all your dimpling needs on your project. The DRDT-2 is painted with an industrial powder coat giving one of the toughest finishes available. Features: • Weight: 60 lbs • Size: 28"X16"X3" • Capacity: Up to 22" depth • Gap: 4" • Skin thickness: Up to 0.040" Aluminum. Dimple Dies: 3/16" shank Diameter.

P/N 12-00907\$391.95

SUNEX PRODUCTS



SX-225RA AIR DRILL – 3/8" reversible. Muffled handle exhaust. Heavy-duty, industrial rated geared chuck.

P/N SX225RA\$66.50



SX-232A ANGLE DIE GRINDER – 1/4", right angle. Rear exhaust. Built in regulator lever throttle for positive speed control.

P/N SX232A.....\$62.25



SX-230A DIE GRINDER & ACCESSORIES – 1/4" air die grinder. Built-in regulator. Exhaust directed away. Lever throttle for positive lever control.

Die Grinder	P/N SX230A.....	\$45.20
Mandrel for 3" Disc	P/N 12-12950.....	\$10.10



SX-229A AIR NIBBLER – Cuts metal without distortion up to 18 gauge. Lever throttle for easy operation. Compact design.

P/N SX229\$100.95



X-227B HEAVY DUTY METAL SHEARS – Muffled handle exhaust. Heavy-duty, ball and needle construction. Pneumatic.

P/N SX227B.....\$109.95



RIVET SHANK REMOVAL PLIERS

Tired of battling those rivet shanks stuck in the ribs and under other underlying structures after you have drilled the heads off and removed the skin? The Rivet Shank Removal Pliers will make short work of this unpleasant task and turn a two man job into a one man job. A handy, patented tool which will reduce labor time and costs.

P/N 12-00745\$65.50



THE RIVET READER

The Rivet Reader is a close tolerance MilSpec manufacturing aid with ten functions. Each Rivet Reader measures 1.5 x the diameter of the rivet shank before riveting, the MIN/MAX upset heights, the MIN/MAX upset diameters, the MIN/MAX edge distances, the diameter of the rivet shank, and the lengths of both universal and flush rivets of all sizes. The tolerances on the Rivet Reader are +/- .001. Sold as a pair for 3/32" and 1/8" rivets.

P/N 12-00806\$18.50



POWER SHEAR

This air-powered shear cuts straight lines or curves up to 180 inches/minute. An ideal shear for any aircraft builder. Cuts up to 18 gauge mild steel. Width of cut: 7/32". Length: 8-1/4". Wt. 2.14 lbs.

P/N 12-01330.....\$253.95

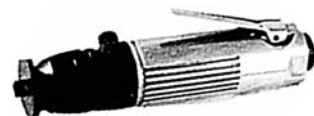

ROUTER

This air-powered router is very light weight and features a straight handle and rear exhaust. Base is 1-1/2" and router guide is included.

RPM: 20,000. Router shank: 1/4". Length: 6". Wt.: 1-1/2.12 Lbs. Made in U.S.A.

P/N US130RD\$247.95



CHIP CHASER

This handy, economical tool removes chips and burrs on metal between sheets after rivet holes have been drilled. A recommended tool for any aircraft builder involved with sheet metal work.

RouterP/N TP70\$6.20

BUCKING BAR KIT

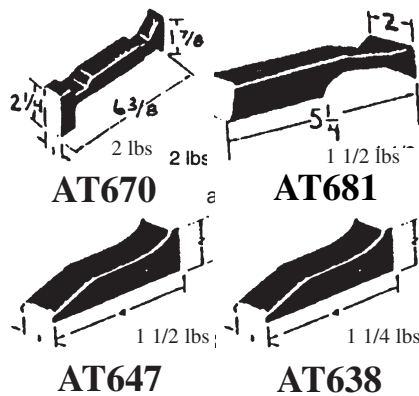

This starter kit contains the most commonly used bucking bars. Multi-finished surfaces for numerous applications for durability.

- 1 AT638 Bucking Bar
- 1 AT681 Bucking Bar
- 1 AT647 Bucking Bar
- 1 AT670 Bucking Bar

P/N 590BBK ..\$79.50

AIR DRILLS (PISTOL TYPE)

These air powered pistol drills feature ergonomic design and use .90 H.P. motors. Sound level is a low 84 db while production output remains high with these high quality drills. Made in U.S.A.



Part No.	RPM	Capacity	Length	Weight	Price
US7387P-4500	4,500	1/4"	5-3/8"	2 lbs	\$225.95
US7387P-2800	2,800	1/4"	5-3/8"	2 lbs.	\$211.95
US7387P-500	500	3/8"	7-1/2"	2.13 lbs.	\$293.95

TO

SHEET METAL TOOLS



MARVEL AIR TOOL OIL

MARVEL brand oil - especially engineered for care of piston-type and rotary air tools. Prevents rust formation while providing lubrication for longer tool life and smoother operation. Keeps your air tools in top shape. A "must" for all air tools. 4 oz. bottle with spout.

P/N 12-00872\$5.45

MICRO-STOP COUNTERSINK CAGES & NYLON FOOT PIECE



2 Models available-one with NEEDLE bearing and one with BRONZE bushings. .001" increment depth adjustment. Positive adjustment lock. 1/4" dia. shank. 9/32" shaft travel. 9/16" cutter capacity. For 1/4-28 threaded cutters. Comes with

"NO-MAR" foot piece. Rated at 3,000 RPM. Made in USA.
With Bronze Bushings.....P/N 12-01412\$38.50
With Needle BearingsP/N 12-00940\$39.80

SQUEEZER SET MIX



6 piece set of the most commonly used squeezer sets shown above: 3/32" & 1/8" cup sets; 1/8" modified cup set; 1/8" & 1/4" flush sets; & 1/16" by 3/8" dia. flush set; plus #4510 organizer block. P/N 12-00882\$6.60

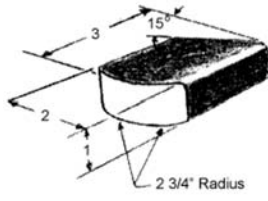

BUCKING BARS

High quality, U.S. Made bucking bars are manufactured from ductile iron and heat treated to 38-42 RC hardness. All sharp edges are deburred and all working surfaces are polished. Working surfaces can be repolished with Scotchbrite without changing hardness.

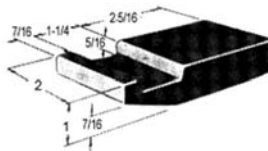

Bucking bar 3" long, 2" wide, 1" high, 2-3/4" 1-1/2 lbs.
AVERY #610.....P/N 12-00887 ..\$20.30
AVERY #615.....P/N 12-00888 ..\$26.90



90° ANGLE DRILL KIT

This angle drill kit includes a drill attachment with quality ball bearing construction for long life. Kit includes 12 threaded drills in assorted sizes and lengths, a mini 3-jaw chuck with 1/16" to 1/4" diameter capacity, and a molded storage case. Made in the U.S.A.

Drill Sizes: 1 ea. #2140 #40 stubby 1 ea. #2130 #30 stubby
2 ea. #3140 #40 short 2 ea. #3130 #30 short
1 ea. #3127 #27 short 1 ea. #3121 #21 short
1 ea. #3112 #12 short 1 ea. #3114 #1/4" short
1 ea. #4140 #40 long 1 ea. #4130 #30 long
1 ea. #20379 Mini 3-jaw chuck
P/N 12-00883.....\$176.95

STOP COUNTERSINK CUTTERS - 100°

• Made in the U.S.A. • High Speed Steel • 1/4" -28 Threaded Shanks
• 100° 3-Flute Precision Ground •For Use in Micro-Stop Countersink Units • 8 Sizes Available

Pilot Size	Decimal Equiv.	Body Dia.	Part No.	Price
#40 (3/32" rivet)	.0980"	3/8"	12-00879	\$12.90
#40 (3/32" rivet)	.0980"	1/2"	12-00942	\$12.90
#30 (1/8" rivet)	.1285"	3/8"	12-00880	\$12.90
#27 (#6 screw)	.1440"	1/2"	12-00943	\$12.90
#20 (#8 screw)	.1610"	1/2"	12-00881	\$12.90
#12 (#10 screw)	.1890"	1/2"	12-00944	\$12.90
5/32" (5/32" rivet)	.1560"	1/2"	12-00945	\$12.90
3/16" (3/16" rivet)	.1875"	1/2"	12-00946	\$12.90
1/4" (1/4" rivet)	.2500"	1/2"	12-00947	\$12.90

360° SWIVEL HAND POP RIVET TOOL

Stanley brand professional hand pop rivet tool. Unique head design swivels 360° for riveting in any position, at any angle. Extended nose for hard to reach places.



Built in handle latch. Die-Cast aluminum & hardened steel construction. Molded grips. Includes (4) interchangeable steel nose-pieces for: 3/32", 1/8", 5/32", & 3/16" P/N 12-00889\$39.95

DELUXE DIMPLE DIE KIT W/BLOCK

This deluxe dimple die kit has all the most commonly used dimple dies in one package--at a special price. This kit includes:

1- 3/32 Dimple Die Set 1- #14870 Female Die / 3/8" Dia.
1- 1/8 Dimple Die Set 1- #14871 1/8" Female Die / 3/8" Dia.
1- #6 Screw Dimple Die Set 1- #8 Screw Dimple Die Set
1- #4520 Organizer Block for Dies

P/N 12-00868\$228.95



DOUBLE OFFSET RIVET SET

SET OF 4 RIVET SETS - 5-1/2" long sets. Used for hard to reach rivets in corners. High alloy steel and heat treated. Shanks are precision ground. Cuppings are polished.

3/32" DOUBLE OFFSET RIVET SETP/N 12-00936\$28.20
AVERY 1/8" DBL OFFSET RIVET STP/N 12-00873\$28.20
5/32" DOUBLE OFFSET RIVET SETP/N 12-00937\$28.30
3/16" DOUBLE OFFSET RIVET SETP/N 12-00938\$28.30
4-PC DOUBLE OFFSET RIVET SETP/N 12-00939\$102.95



SCOTCH-BRITE CUTTING & POLISHING WHEEL KIT

3M SCOTCH-BRITE wheels are a uniform blend of minerals and resins molded into wheel form with rugged, dense construction that provides aggressive polishing and blending action without removing

excess base materials. These wheels generate uniform finishes and can remove minor surface imperfections. Use these wheels with a die grinder for deburring holes and edges. Small wheels are more versatile than large (6") wheels. Can be used on hand held parts or parts in the jig. These wheels are the same density, grade, and mineral type as the 7A MED 6" wheel. Both mandrels have 1/4" shanks. (Sold as a kit or as separate items). P/N 12-00876\$49.90



DRIVE PIN PUNCHES

Drive Pin Punch 1/16"P/N 12-00949\$6.40
Drive Pin Punch 3/32"P/N 12-00870\$6.40
Drive Pin Punch 1/8"P/N 12-00871\$6.40

3M SCOTCH-BRITE DEBURRING WHEEL

Use to radius and deburr edges of aluminum parts. These wheels give a uniform brushed satin finish to parts and deburr quicker and easier than hand finishing. These wheels are discs of Scotch-Brite web compressed and bonded to form a rugged, dense wheel. Wheel size: 6" dia. x 1" wide x 1/2" thru hole. Two styles available.

Cut & Polish/Unitized Wheel-7A Medium grade (harder)
P/N 12-00875\$59.85
Light Deburring Wheel-7S Fine Grade (Softer)
P/N 12-00948\$149.95

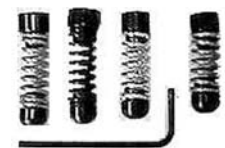

4-PIECE DRILL STOP SET

Use when drilling in sheet metal to help eliminate drill breakage & surface marks. Safely keeps drill from going too far through the work. Drill stops have a coiled spring to cushion the drill breakthrough & prevents the drill chuck from marring the work surface. Color coded for easy identification. P/N 12-00867\$13.30

TO

SHEET METAL TOOLS

POLYETHYLENE DIMPLING Mallet



This custom made UHMW polyethylene plastic mallet is great for dimpling skins. Blows are more solid and much quieter than with steel hammers. Will outlast wood mallets. Hammer head measures 2.5" round x 4" long with 12" handle. Wt: 16oz.
P/N 12-00605\$23.90

METAL FORMING SHOT BAG



For those builders that want to try their hand at metal forming this leather shot bag is a must have item. Leather shot bag made from 3/4 oz. top grain cowhide. The bag is double stitched and fills through a 1" opening sealed with Velcro. The bag is 12" round and 1-1/2" thick. Use lead shot #8 - #7.5; or sand - mortar quality type (shot can be purchased at local sporting goods or gun stores).
P/N 12-00606\$76.50

PLASTIC FORMING Mallet



This custom made UHMW polyethylene plastic forming mallet is great for metal forming. Smooth radiused surfaces will not mar surface. Long life, split resistant. Mallet head measures 2.5" round X 5" long w/ 11" handle; Wt: 14 oz. Great combo to the shot bag.
P/N 12-00607\$23.90

HAND SEAMER/3.5" JAW



Has VISE GRIP locking feature to aid clamping & holding work. Use for straightening and bending rib and bulkhead flanges. Made in our shop with 7" vise grip plier. Jaws are made from 3/16" X 1" X 3-1/2" stainless steel with machined radius. TIG welded & polished.
P/N 12-00608\$34.40

FLUTING PLIER



Make narrow & precise flutes for straightening ribs and bulkheads easier & better than pliers with molded jaws. Made in our shop with 7" VISE GRIP pliers. Pins are 3/16" dia. stainless steel. TIG welded & polished. P/N 12-00609\$32.90

FLUTING PLIER/PLIER TYPE



Make narrow & precise flutes for straightening ribs and bulkheads easier & better than pliers with molded jaws. Made in our shop with 7" VISE GRIP pliers. Pins are 3/16" dia. stainless steel. TIG welded & polished.
P/N 12-00610\$34.75

VISE GRIP DIMPLERS



Made for dimpling in restricted and hard to reach places where regular dimple dies won't fit. Made in our shop with 7" VISE GRIP plier. Machined tool steel dimple dies are T.I.G. welded to the VISE GRIP jaws then polished. 2 sizes available (3/32" and 1/8").
3/32"P/N 12-00611\$34.85
1/8"P/N 12-00612\$34.85

ADJUSTABLE SET HOLDER FOR PNEUMATIC SQUEEZERS



New improved design. Heat treated 4130 steel investment casting with rolled threads. This special set holder is made to replace the rigid (2-9/16") set holder standard to most CP214 style pneumatic squeezers. This adjustable set holder will eliminate the need to shim the dies and sets with shim washers. Adjustments are faster & easier.
P/N 12-00615\$64.75
Note: Only for yokes with 1" thick base or less. Will not work in tandem units.

POP GRIP DIMPLERS AN-426 RIVETS



For dimpling in hard to reach places. Works with any hand pop rivet tool. Can be used over & over. Works for both 100 & 120 pop rivets. Extra nails included (Uses standard hardware store nails). 2 sizes available.
3/32"P/N 12-00613\$15.90
1/8"P/N 12-00614\$14.90

Note: The pop rivet dimplers show above are made with 100° angles, same as regular dimple dies. They will work with either solid flush rivets (AN-426 - 100°) or with pull type rivets such as a AVEX rivets (120°), etc. The dimple formed with these pop rivet dies will not be as 'sharp' as dimples formed with regular dimple dies. This is because you get more pressure with a squeezer or a hammer than with a pop rivet puller; however, the dimples formed with pop rivet dimplers are adequate for occasional use in tight or hard-to-use places.

FLUSH SWIVEL RIVET SET



U.S. MADE -- ATI Brand. New design flush rivet set with swivel action eliminates problem of rivet gun alignment with the work surface + rubber guard to reduce slippage while flush riveting. .401" shank X 1-1/4" dia. polished face. Built-in retaining spring. P/N 12-0074146.30

BACK RIVETING PLATE



Back riveting requires a hard flat surface to act as a bucking bar while you set the shop head of the rivet. Our plate is a perfect hard & flat surface for "Back Riveting". 3/8" thick X 4" wide X 15" long. Low carbon steel plate with flat ground surface. Weight 10 lbs. P/N 12-00618\$39.90

HOLE FLANGING TOOL



For forming flanges around lightening holes. Made from 2024 aluminum and hard black anodized. Ball bearing style rollers. Comes with spare set of rollers.
P/N 12-00619\$13.95

SPARE ROLLER-SET OF 2



Replacement rollers for our edge rolling & hole flanging tools (above).
P/N 12-00621\$1.95

TO

SHEET METAL TOOLS

SPEED DEBURRING & C'SINKING TOOL

Swivel action - makes deburr & c'sink holes fast & easy. Molded handle with 2" long plated steel "Dog-leg" shaft with 1/4"-28 threaded holder. Includes (1) 3/8" X 100° 3-flute burring cutter (part #1050) + 8" extension shaft for deburring the inside of flanges & other hard to reach holes. P/N 12-00622**\$26.00**

Handle and Extension Shaft sold separately

Swivel handle onlyP/N 12-00623**\$11.80**
 Extension Shaft onlyP/N 12-00624**\$5.95**

HSS THREE FLUTE BURRING CUTTER - 100°



US made. High speed steel, precision ground, three flute burring cutter. 3/8" diameter X 100° with 1/4"-28 threaded shank. Same style as a countersink but without the pilot. P/N 12-00625**\$15.60**

"NO-MAR" REUSABLE CLECO BOOTS



Eliminates surface marring both on painted and unpainted surfaces. Easily slips on plier operated style clecos, one size fits all. Yellow polyurethane color. 25 pcs./pkg. P/N 12-00626**\$6.60**

TEMPORARY ASSEMBLY PINS



Initial fitting of control surfaces require multiple installation and removals of the parts to fit, trim, and adjust everything. These temporary assembly pins make the task quicker and easier. Pins are 3/16" diameter with tapered points and angle bends for easy installation. The pins are threaded so the pin holder can be removed — this is necessary to prevent damage should you move the control surface too far during fitting. To remove pins just screw holder back on pin and remove pin. Packaged in sets: 6 pins / 2 holders. P/N 12-00627**\$11.95**

BOLT GRIP



This new tool lightly grips the heads of bolts and screws for easier insertion into tight or blind spots. No more dropped or lost parts. Tool has one end for -3 (3/16") fasteners and one for -4 (1/4") fasteners. 12" overall length. P/N 12-00628**\$14.30**

DOUBLE EDGE DEBURRING TOOL



Used to quickly deburr edges of sheets up to 1/8" thick. Save time and motion deburring edges of parts. Precision ground Carbide "V" shape blade with hex aluminum handle. Non-removable cutter style. P/N 12-00629**\$14.85**

EDGE MARKER BLOCK



This handy device holds a marking pen and has an adjustable stop for running along the edge of a part. The adjustable stop allows variable edge distance for rivet layout, etc. One thumbscrew holds the pen (pen sold separately) and the other thumbscrew holds the adjustable stop. Made from delrin (plastic) material. Comes ready to use with (1) Pilot marking pen. P/N 12-00630**\$11.95**

SHOP HEAD RIVET GAUGE SET



Set of four gauges for -3, -4, -5, & -6 rivets. Each gauge measures MINIMUM height and MINIMUM diameter of shop heads AFTER setting. Eliminates guessing if your rivets are properly set. Works for measuring both universal head and flush rivets. Precision machined to size from 2024 aluminum. Rivet size permanently stamped on each gauge. Color coded anodized finish. Instructions included. P/N 12-00631**\$15.85**

EDGE ROLLING TOOL



For pre-bending skin edges on lap joints and butt joints before riveting. "Edge rolling" will prevent skin edges from curling up during riveting. Machined round body made in our shop from 2024 aluminum. Hard black anodized finish for wear resistance. Ball bearing style nylon rollers (non marking); + spare set of rollers and instructions included. P/N 12-00632**\$17.95**

RIVET LENGTH GAUGE



One gauge measures -3, -4, -5, & -6 rivets. Used to check for proper length of rivets BEFORE setting. Eliminates measuring and guessing of rivet lengths. Works for both universal head and flush rivets. Precision machined to size from 2024 aluminum. Rivet sizes permanently stamped. Gold anodized finish. Instructions included. P/N 12-00633**\$6.90**

RV JACK STAND KIT

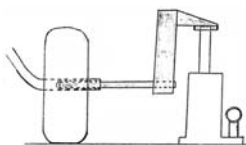

Someday you'll need to jack up your aircraft for install new tires, clean & grease wheel bearings, or fix a flat. This nifty jack stand is made by Larry Vetterman of Vetterman Exhausts. Safer than using the engine hoist on the engine strap (Larry says that's an expensive method should you break the top out of the engine case) and putting a jack at the wing tie down location can also be scary. Requires a modification to the axle nuts (about 1 hour). Kit includes the axle jack arm, axle modification hardware, & directions to modify the nuts. Uses automatic bottle jack. (Jack not included). P/N 12-00634**\$39.65**

RUDDER CABLE FAIRING SETS FOR RV's



Pre-formed .025" thick aluminum fairings for rudder cable exit on RV fuselages. (None are supplied with the RV kits). Set contains (3) identical fairings — 2 for use on cables & 1 spare (could be used on elevator trim). Each will require some trimming to fit before riveting. P/N 12-00635**\$9.90**

TO

METAL WORKING TOOLS



SHOT BAGS

These shot bags are made out of .070/.090 thick top grain cowhide for extended life and to produce a blemish-free metal surface. These bags have suede outer or forming surface and a tanned inner surface to resist abrasive wear from the media. Convenient media filter and reinforced flap with velcro seal is provided. All bags are approximately 1.5" to 2" thick when filled. Can be filled with buckshot or silica sand (not included) found at most sporting good stores.

Model No.	Size (inches)	Part No.	Price
SB8	8"	12-00995	\$24.95
SB12	12"	12-00996	\$33.00
SB18	18"	12-00997	\$45.60
SBR18 (rectangular)	18"x12"	12-00998	\$65.00



PANEL BEATER HAMMER & DOLLY KIT

The most widely used selection of panel beaters and dollies for most metal shaping needs, professional grade in a molded plastic box. Each hammer is color-coded for either shrinking (blue) or stretching (red) forming tasks. The 3 panel beaters included are the dinging, shallow-domed face and pick hammer combo. The dollies included are the thin toe, utility, curved and heel shapes, providing the user with the best combination kit on the market. See the individual sections on panel beaters and dollies for more specifications on each item. 8-piece kit includes: • DT2566, DT2560 & DDT2537 panel beaters • CP548, CP552, CP553, & CP554 dollies • Blow molded plastic case. All tools made from medium carbon steel, forged, heat treated and mechanically polished for years of continuous service. Weight: 16.5 lbs.; size: 16.5"L x 14"W x 4"H.

P/N 12-01011.....\$118.95

T-DOLLIES



Simple, but necessary forming tool allows you to create new flanges or straighten out damaged flanges. Can be used effectively by taking to an existing body panel or locked in bench vise and create an exact radius edge using any flat faced panel beater or wood slapper. T-dollies are fabricated out of carbon steel hardened and zinc plated to provide years of service life. Extra long flat handle. Heads have radius ends.

Model No.	Size (inches)	Part No.	Price
DCTD01	1"x 8"	12-01019	\$20.00
DCTD02	3/4"x 6"	12-01020	\$15.90
DCTD03	1"x 8"	12-01021	\$25.00
DCTD 3-pc. kit (8lbs.)		12-01022	\$68.00

CURVED T-DOLLIES

Simple, but necessary forming tool allows you to create new flanges or straighten out damaged flanges. Can be used effectively by taking to an existing body panel or locked in bench vise and create an exact radius edge using any flat faced panel beater or wood slapper. T-dollies are fabricated out of carbon steel hardened and zinc plated to provide years of service life. Extra long flat handle. Heads have radius ends.

Model No.	Size (inches)	Weight	Part No.	Price
DCTD01 - Gentle curve	1"x 8"	2.9 lbs.	12-01023	\$69.50
DCTD02 - Crescent Curve	3/4" x 8"	2.4 lbs.	12-01024	\$66.25
DCTD03 - Slope Curve	3/4" x 9"	2.2 lbs.	12-01025	\$68.75
DCTD 3-pc. kit (8lbs.)			12-01026	\$172.95



HARDWOOD SLAPPER

These slappers are made from grade A select midwestern grown hard maple for toughness, stiffness and durability. With an ergonomically designed grip area, the hand and wrist are positioned in a neutral and natural condition. Finished with protective oil that resists staining and guards against moisture penetration. 4 different shapes: gentle, medium, flat, and radius face. The new thinner cross-section of 2-1/4" allows working a tighter radius in more confined areas. Each slapper comes with a leather face cover to eliminate marring of the metal.

Model	Shape Style	Overall Length	Surface Length	Face Width	Weight (Lbs.)	Part No.	Price
SP1	Gentle	14"	8.5"	2.25"	1.3	12-00999	\$51.50
SP2	Medium	14"	8.5"	2.25"	1.3	12-01001	\$51.50
SP3	Flat	14"	8"	2.25"	1.3	12-01002	\$51.50
SP4*	Radius	14"	8.5"	2.25"	1.3	12-01003	\$54.75
SLP-001L Replacement leather cover & hardware						12-01004	\$14.95

HAND FORMING DOLLIES



These professional series hand dollies are a complete selection of shapes and weights for most forming needs. These dollies can be used with panel beaters or wood slappers. Dollies weight and shape impacts the flow of the metal. Choose weights according to sheet metal thickness. Medium carbon steel, forged, ground, heat treated and mechanically polished for years of continuous use.

Model No.	Weight (lbs)	Part No.	Price
CP548	2.02	12-01005	\$25.40
CP552	2.85	12-01006	\$25.40
CP553	2.55	12-01007	\$25.40
CP554	1.97	12-01008	\$25.40
CP555	3.94	12-01009	\$34.30
CP556	3.40	12-01010	\$32.80



PANEL BEATER HAMMERS

These professional series panel beater hammers are uniquely balanced acting as a natural extension to the users own hand. Creating excellent feel and feedback each an every time you contact the metal. Each hamer style is color coded for easy recognition: Shrinking (blue) or stretching (red) operations.

Model No.	Head Wt./lbs	Overall Length	"A"	"L"	"B"	Part No.	Price
DT2537	.67	13"	1.6"	5.5"	-	12-01027	\$27.40
DT2566	.57	13"	1.5"	5.4"	-	12-01029	\$27.40
DT2560	.70	13"	1.6"	3.8"	1.5"	12-01028	\$29.85
DT2569	.70	13"	1.6"	3.8"	1.6"	12-01030	\$29.85

BOSSING MALLETS EXTENDED REACH

These extended depth plastic mallets allow deeper reach and a more aggressive and fuller finished shape. The UHMW polyethylene heads are lightweight, resistant to wear and non-marring. Hickory handles with full round shafts. When paired with shot bags, very creative, roughed out forms can be accomplished.

Model No.	Small radius dia.	Large radius dia.	Overall head lgth	Head dia.	Weight (lbs.)	Part No.	Price
DBM01	1/2"	2-1/4"	7"	2"	.70	12-01031	\$44.00
DBM02	3/4"	1-3/8"	8"	2-3/4"	1.3	12-01032	\$46.00
DBM03	1"	3"	7"	3"	1.5	12-01033	\$49.00

TO

SPECIALTY TOOLS FROM AIRCRAFT SPRUCE

HAND RIVET SQUEEZER



Features includes an all-steel construction, adjustable set holder (accepts all sets with 3/16" shank), and long handles for increased force. The yoke is made of the highest quality tool steel, and by simply removing 3 pins you can change the yoke to match your riveting or dimpling application.

Description	Part No.	Price	Description	Part No.	Price
1" Squeezer	12-01460	\$68.35	1" Yoke	12-01457	\$22.30
2" Squeezer	12-01461	\$68.90	2" Yoke	1201458	\$22.90
3" Squeezer	12-01462	\$69.85	3" Yoke	12-01459	\$23.95

STAINLESS STEEL HAND SQUEEZER



This stainless steel hand squeeze made of quality stainless steel construction. Features include an adjustable set holder (accepts all sets and dies with 3/16" shank) and a locking lever arm. Yokes are easily interchangeable by simply removing three roll pins and designed to accept yokes and parts made by other stainless steel hand squeeze manufacturers.

1-1/2" P/N 12-01463.....	\$98.75
3" P/N 12-01464.....	\$104.85

INTEGRAL WHOLE TYPE HAND SQUEEZER



A basic tool for all riveting operations. Quality steel construction with black oxide finish and all parts are heat treated. Adjustable set holder accepts dies and sets with 3/16" shank. 1-1/2" reach x 1-1/2" gap.

1-1/2" P/N 12-01465.....	\$53.70
--------------------------	----------------

RIVET SET FOR SQUEEZER (FLUSH & CUPPED)



Made of steel and heat-treated for long wear and tool life. .187" (3/16") shank.

Flush P/N 12-01466.....	\$1.45
Cupped P/N 12-01467.....	\$1.95



DIMPLE DIE SET

For any .187 shank diameter squeezer.

P/N 12-01468.....	\$9.45
-------------------	---------------



SCREW REMOVAL TOOL

- Useful in removing screws that are corroded or have stripped heads
- .401 Parker taper shank for use in rivet gun
- 3/8" square socket end with 1/4" hex adapter included
- Use standard Phillips or Slotted insert bits
- Rivet gun required

P/N 12-01469.....	\$16.35
-------------------	----------------

MICRO STOP

This tool permits you to set the desired cut depth to help eliminate mistakes and skin damage.



- 1/4" Shaft travel
- Depth adjustable in .001" increments
- 1/4"-28 Female Threads
- Rated for 3,000 RPM

P/N 12-01470.....	\$18.75
-------------------	----------------



HEAVY DUTY RIVET CUTTER

This high quality, durable rivet cutter features all steel construction and cuts 1/16" to 1/4" diameter rivets. It is adjustable for 1/4" to 3/4" long rivets.

P/N 12-01471.....	\$38.90
-------------------	----------------

ECONOMY SAFETY WIRE TWISTERS



These top quality twisting lock pliers with automatic return are economically priced and extremely durable. Features a sharp cutting edge and will twist up to .060" dia. safety wire. Length 6" & 9". Foreign made.

6" P/N 12-01472.....	\$15.75
12" P/N 12-01473.....	\$17.95



CAMLOC PLIERS

P/N 12-01475	\$14.50
--------------------	----------------

ALUMINUM BODY MINI AIR VACUUM



A handy air powered vacuum works off an air compressor and is simple to use. Attached 12" clear plasticflex tube can easily get into tiny spaces to clean. The canvas bag is easily removed for cleaning.

P/N 12-01474	\$14.65
--------------------	----------------



CHIP CHASER

Ideal for removing chips and burrs from between metal after drilling rivet holes. Each chaser features a plastic molded handle and flexible steel blade with hook on the end. Blades are 5.5" and 2.5" long.

P/N 12-01476	\$2.85
--------------------	---------------



DOGLEG DEBURRING TOOL

Swivel action of this tool makes deburring holes fast and easy. Shaft includes a 1/4"-28 threaded holder.

P/N 12-01478	\$9.95
--------------------	---------------



BURNISHING SPOON

Designed to remove surface blemishes in aircraft sheet metal. Hard chrome plated. Comfort grip handle.

P/N 12-01479	\$8.25
--------------------	---------------



CLECO PLIERS

Used in limited access areas, requires less travel per activation.

P/N 12-01480.....	\$3.85
-------------------	---------------

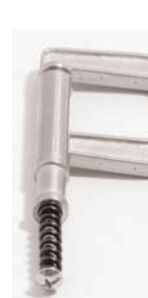

SPRING TENSION CLAMPS (ZINC ALLOY YOKE OR STEEL YOKE)

Spring tension clamps can be applied in a fraction of the time required for ordinary screw clamps. The clamp, with 2" throat depth, has a Zamak alloy yoke and a steel spring which provides a 70 lb. clamping pressure. Designed for use with sheet holder pliers. **\$57.00**

Description	Part No.	Price
Zinc Alloy	12-01481	\$3.90
Steel 2"	12-01482	\$5.95
Steel 3"	12-01483	\$6.75

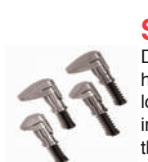

SIDE GRIP CLAMPS

Designed to hold two or more work pieces together where no holes exist. Clamping force is applied at edge of work. Spring loaded, plier actuated. The lack of a takeup screw makes it impossible to over-tighten and damage the work surfaces or the clamp. There are 4 standard sizes : 1/2 x 1/2", 1/2 x 1", 3/4 x 1/2", 3/4 x 1".

Description	Part No.	Price	Description	Part No.	Price
1/2" x 1/2"	12-01484	\$1.65	#10	12-01488	\$0.75
1/2" x 1"	12-01485	\$1.80	#20	12-01489	\$0.75
3/4" x 1/2"	12-01486	\$1.65	#30	12-01490	\$0.75
3/4" x 1"	12-01487	\$1.80	#40	12-01491	\$0.75



DRILL STOPS

Use when drilling in sheet metal to help eliminate drill breakage & surface marks. Safely keeps drill from going too far through the work. Drill stops have a coiled spring to cushion the drill breakthrough & prevents the drill chuck from marring the work surface. Color coded for easy identification.

#1/4 P/N 12-01492	\$0.92
#5/16 P/N 12-01493	\$0.92



CYLINDER BASE NUT WRENCHES

Where torque application accuracy is critical these tools meet the requirement. They offer excellent rigidity and surpass other wrenches in overall quality and efficiency. Wrench Type A is for sizes 1/2", 9/16", 5/8", and 3/4" hex nuts. Wrench Type B is for 3/8" and 1/2" internal hex.

TYPE A P/N 12-01525.....	\$11.35
TYPE B P/N 12-01526.....	\$14.50

TO

SPECIALTY TOOLS FROM AIRCRAFT SPRUCE

STRAP DUPLICATOR (BUSHING TYPE)



For drilling an accurate hole in overlapping sheets. The Bushing type duplicator is used by sliding the end with the pin between the sheets and locating the hole to be duplicated from inside. #10?#21?#30?#40?1/4 drill sizes, 6 1/4" or 13 1/4" lengths.

Description	Part No.	Price	Description	Part No.	Price
#10 6-1/4"	12-01494	\$3.85	#10 13-1/4"	12-01499	\$4.25
#20 6-1/4"	12-01495	\$3.85	#20 13-1/4"	12-01501	\$4.25
#30 6-1/4"	12-01496	\$3.85	#30 13-1/4"	12-01502	\$4.25
#40 6-1/4"	12-01497	\$3.85	#40 13-1/4"	12-01503	\$4.25
1/4" 6-1/4"	12-01498	\$3.85	1/4" 13-1/4"	12-01504	\$4.25

STRAP DUPLICATOR (PUNCH TYPE)



For drilling an accurate hole in overlapping sheets. The punch type duplicator comes with hardened marking pin. Permit the marking sheet metal from a hidden pilot hole. #10?#21?#30?#40?1/4 drill sizes, 6 1/4" or 13 1/4" lengths.

Description	Part No.	Price	Description	Part No.	Price
#10 6-1/4"	12-01505	\$3.85	#10 13-1/4"	12-01510	\$4.25
#20 6-1/4"	12-01506	\$3.85	#20 13-1/4"	12-01511	\$4.25
#30 6-1/4"	12-01507	\$3.85	#30 13-1/4"	12-01512	\$4.25
#40 6-1/4"	12-01508	\$3.85	#40 13-1/4"	12-01513	\$4.25
1/4" 6-1/4"	12-01509	\$3.85	1/4" 13-1/4"	12-01514	\$4.25

STRAP DUPLICATOR (BUSHING TYPE)



For drilling an accurate hole in overlapping sheets. The Bushing type duplicator is used by sliding the end with the pin between the sheets and locating the hole to be duplicated from inside. #10?#21?#30?#40?1/4

drill sizes, 6 1/4" or 13 1/4" lengths.

Description	Part No.	Price	Description	Part No.	Price
#10 6-1/4"	12-01515	\$5.80	#10 13-1/4"	12-01520	\$5.95
#20 6-1/4"	12-01516	\$5.80	#20 13-1/4"	12-01521	\$5.95
#30 6-1/4"	12-01517	\$5.80	#30 13-1/4"	12-01522	\$5.95
#40 6-1/4"	12-01518	\$5.80	#40 13-1/4"	12-01523	\$5.95
1/4" 6-1/4"	12-01519	\$5.80	1/4" 13-1/4"	12-01524	\$5.95

EDGE BREAKER



This tool allows the quick removal of burrs and roughness from the edges of sheet metal. .25" or .187" in diameter grooved blade with safety shield. Safety-grip plastic handle.

P/N 12-01527.....\$8.20

HAND SEAMER



Large jaws are machined for smooth, parallel fit. Forms precise folds and seams. Has rounded jaws to prevent tearing when bending of aluminum and other light metals. Depth of throat 1". Width of jaws 3-1/2". Overall length 8".

P/N 12-01528\$12.35

AIR SWIVEL CONNECTOR



360° swivel connector reduces air hose kinking and twisting. Improves tool maneuverability, minimizes operator fatigue, and extends hose life. 1/4" NPT thread size on both ends.

P/N 12-01529\$8.35

BRASS RIVET SET



This rivet set has a soft face to prevent damage to the fastener when inserted or removed. Fits into any standard rivet gun or air hammer that supports .401" shank tooling, 3 1/8" overall length.

P/N 12-01543\$7.45

RIVET GUN SHAFT REDUCER



Rivet set adapter sleeve, .401 shank. Made of hardened steel (SKD11) and is open at both ends to allow maximum riveting power.

P/N 12-01544\$12.25

AIR SWIVEL CONNECTOR WITH REGULATOR



360° swivel connector reduces air hose kinking and twisting. Improves tool maneuverability, minimizes operator fatigue, and extends hose life. Has a built-in fingertip control regulator. 1/4" NPT thread size on both ends.

P/N 12-01530\$11.45

CANNON CONNECTOR PLIERS



The tool features serrated jaws for improved gripping and a slip joint for improved leverage. Ideal for all common cannon connector applications.

P/N 12-01531\$13.35

RIVET REMOVAL TOOL



This quality tool enables the user to quickly and accurately remove rivets and blind fasteners. Comes complete with drill bits and guides, #40, #30, #21, & #10.

P/N 12-01532\$38.85

SHOP HEAD RIVET GAUGE SET



Set of four gauges for -3, -4, -5, -6 rivets. Each gauge measures Minimum height and Minimum diameter of shop heads AFTER setting. Eliminates guessing if your rivets are properly

set. Works for measuring both universal head and flush rivets. Precision machined to size from 2024 aluminum. Rivet size permanently stamped on each gauge. Color coded anodized finish.

P/N 12-01533\$6.25

RIVET LENGTH GAUGE



One gauge measure -3, -4, -5, -6 rivets. Used to check for proper length of rivets Before setting. Eliminates measuring and guessing of rivets lengths. Works for both universal head and flush rivets. Precision machined to size from 2024 aluminum. Rivet size permanently stamped. Blue anodized finish.

P/N 12-01534\$3.90

DRILL EXTENSION THREADED



Used to extend drill bits, countersinks, etc. Extension has a 1/4" shank on one end and 1/4"-28 female threads on other end. Comes in five different lengths 2" 4" 6" 7" 10".

Description	Part No.	Price	Description	Part No.	Price
2"	12-01535	\$3.25	7"	12-01538	\$3.25
4"	12-01536	\$3.25	12"	12-01539	\$3.25
6"	12-01537	\$3.25			

DRILL EXTENSION DUAL THREADED



Use these different length extensions in your 90° or 45° drills. 1/4"-28 male threads on one end and 1/4"-28 female threads on other. Comes in three different lengths 1" 2" 4".

1" P/N 12-01540\$3.60
2" P/N 12-01541\$3.60
4" P/N 12-01542\$3.60

AIR TOOL REGULATOR



Solid brass construction with positive adjustment. Easy to read numbered dial. 1/4" NPT threads on both sides

P/N 12-01545\$7.50

BRAKING LINING TOOL



This is the original brake rivet tool designed for replacing small aircraft brake pads. Simply mount the tool in a vise, align the rivet to the panel and strike the punch with a hammer. This easily removes the old pad. For installation, install the new pad and rivet and align to the rivet set. Gently strike the set to upset the rivet.

P/N 12-01546.....\$11.35

1-1/2" AND 3 YOKES



- Holds 3/16" die sets
- Adjustable set holder
- Stainless steel construction

1-1/2" P/N 12-01547\$33.70
3" P/N 12-01548\$42.65

TO

ATS TOOLS-PORTABLE COMPRESSORS

PORTABLE COMPRESSORS



- Hot Dog**
- 6 Gallon Tank
 - Runs at 3300 rpm
 - 2 HP motor
 - 4.1 - 5.1 @ 90 PSI
 - Weight 57 lbs.
 - Recommended for Pneumatic Tools

P/N 12-01407
\$149.00



- Pancake**
- 4 Gallon Tank
 - Runs at 3300 rpm
 - 2 HP motor
 - 4.1 - 5.1 @ 90 PSI
 - Weight 62 lbs.

P/N 12-01408
\$149.00



- Twin Tanker**
- Two 2 Gallon Tanks
 - Runs at 3300 rpm
 - 2 HP motor
 - 4.1 - 5.1 @ 90 PSI
 - Weight 60 lbs.
 - Recommended for Paint Guns

P/N 12-01409
\$149.00

ATS TOOLS

ATS AIR NIBBLER



- ATS8300**
- Cuts up to 16 ga (.060" / 15 mm) steel or aluminum
 - Easily replaceable punch and die
 - Weight 1.74 lbs (.79 kg)
- P/N 12-01414.....\$89.95

ATS MINI ANGLE DIE GRINDER



- ATS5105**
- 1/4" (6.4 mm) Collet Size
 - 5-1/2" (140 mm) Overall Length
 - 1.1 lbs (.5 kg)
 - 20,000 RPM Free Speed)
- P/N 12-01416.....\$75.95

ATS HEAVY DUTY AIR DRILL



- ATS6101**
- 3/8" (9.5 mm) Jacobs® Chuck
 - Full Cage Gear
 - 2,600 RPM
 - Variable speed control
 - .67 hp (.5 kw)
 - Ergonomic Design for Maximum Comfort
 - 7-1/2" (190 mm) Overall Length
 - 2.07 lbs (.94 kg)
- P/N 12-01418.....\$65.00

ATS PUNCH & FLANGING TOOLS



- ATS8400**
- Capacity 16ga (.060"/15mm) steel
 - Punch Diameter 3/16" (5 mm)
 - Flange width 1/2" (12 mm)
 - Rubber comfort grip
 - 9-3/4" (248 mm) Overall Length
 - 2.75 lbs (1.25 kg)
- P/N 12-01413.....\$99.95

ATS MINI DIE GRINDER



- ATS5101**
- 1/4" (6.4 mm) Collet Size
 - Front exhaust keeps work area clean!
 - Very light weight .79 lbs (.36 kg)
 - 26,000 RPM Free Speed)
- P/N 12-01417.....\$59.95

ATS HD REVERSIBLE AIR DRILL



- ATS6104**
- 3/8" (9.5 mm) Jacobs® Chuck
 - Full Cage Gear For Smooth Operation
 - 2,400 RPM • Variable Speed Control
 - Fully Reversible with Positive Stop
 - 7-1/2" (190 mm) Overall Length
 - .67 hp (.5 kw)
 - 2.86 lbs (1.3 kg)
- P/N 12-01421.....\$69.95

ATS AIR POWER RECIPROCATING SAW KIT



- ATS8202K**
- Cuts up to 16 ga (.060" / 15 mm) steel or aluminum
 - .063" (16, mm) Stroke Length
 - 10,000 Strokes Per Minute (SPM)
 - Weight 2.1 lbs (1.35 kg)
- P/N 12-01419.....\$89.95

ATS 3" CUT-OFF TOOL



- ATS8502**
- 3" (75 mm) disc capacity, 3/8" (15 mm) mount
 - Free speed 20,000 RPM
 - Weight 1.74 lbs (.79 kg)
- P/N 12-01420.....\$53.59

ATS PALM DRILL



- ATS6100**
- 1/4" (6.4 mm) Jacobs® Chuck
 - Two-stage (Low/High) Control Trigger
 - 5-7/8" (150 mm) Overall Length
 - 1.54 lbs (.7 kg)
 - 2,800 RPM Free Speed
- P/N 12-01424.....\$99.95

ATS 90 DEGREE ANGLE DRILL



- ATS6132**
- Spindle 1/4"-28 Thread
 - Head Length 1.08" (2.7 mm)
 - 2,800 RPM
 - Head Width .65" (1.6 mm) .33 hp
 - 10" (254 mm) Overall Length
 - Variable speed control
 - 1.6 lbs (.73 kg)
- P/N 12-01422.....\$235.00

ATS AIR HYDRAULIC RIVETER



- ATS8805**
- Pulling Force 2,300 lbs (1,045 Kg)
 - Rivet Capacity 3/16" aluminum or mild steel
 - Stroke Length .63" (16 mm)
 - Nosepieces: 3/32" (2.4 mm), 1/8" (3.2 mm), 5/32" (4.0 mm), 3/16" (4.8 mm)
 - Weight 3.26 lbs (1.48 kg)
- P/N 12-01423.....\$79.95

TO

ENGINE TOOLS

VALVE WOBBLE TEST FIXTURE

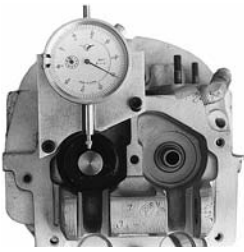

The Valve Wobble Test Fixture for parallel valve Lycoming engines is used to comply with Lycoming SB-388a. Quality made of aluminum and alloy steel, it is easy to use with no set screws or feeler gauges required. Allows direct reading of wobble from dial indicator.

- Fixture without indicator
P/N 12-21500\$102.95
- Fixture with indicator
P/N 12-21505\$127.95

DISTRIBUTOR BLOCK SPRING INSTALLATION TOOL



This tool facilitates the proper installation of contact springs on Bendix magnetos. The O-ring locator ring assures proper location of the tool in the contact tower. Features knurled body grip and ball plunger grip. Made of alloy steel P/N 12-21510\$71.50

VALVE SPRING COMPRESSOR



This tool is used to compress valve springs during valve removal and installation. It is ergonomically designed for shop and field use and comes with special pivot pin. Features alloy steel construction with nickel plating.

P/N 12-00202\$51.50

ELECTRODE SPREADING TOOL



This tool is used to increase the electrode gap on all massive electrode spark plugs. It is constructed from heat treated alloy steel and is nickel plated. P/N 12-51520\$13.50

SPARK PLUG SERVICE KIT



Our spark plug service kit includes the Precision Gap gapping tool which is easy to use, features fine thread adjuster and ball pressure tips, and works on all massive electrode plugs. Also includes the 18mm Thread Cleanout Tool with spring loaded jaws which offer maximum thread penetration & control carbon build-up in threads. Completing the Kit is a double-end Gap Plug Gauge which features an aluminum handle and is easy to use. Kit comes complete with durable birchwood storage case.

P/N 12-21525\$81.90

THROTTLE SHAFT BUTTERFLY SCREW STAKING TOOL



This quality made alloy steel tool facilitates the proper staking of throttle shaft butterfly screws and eliminates the possibility of damaging the carburetor during staking. The tool can easily be operated by one person on the bench without chisels, special fixturing or hammers. All wear components are easily replaceable for long service life. P/N 12-21528\$89.50/ea.

SAFETY MAG LOCK TOOL



This handy tool fits most Bendix magnetos and prevents damage to distributor gear teeth brought about by accidental turning of the engine during magneto installation. Use for E gap or engine timing. Body taper locks into timing window. Polyurethane rubber throughout.

P/N 12-21535\$6.95

LYCOMING TIMING POINTER



This tool is used to align timing numbers and marks to the crankcase parting line on Lycoming engines. It permits timing from the marks on the aft side of the flywheel. A spring clip holds the tool to the flywheel.

P/N 12-21540\$30.40

CONTINENTAL O-200 TIMING POINTER



This tool is used to align timing numbers and marks to the crankcase parting line on the Continental O-200 engine. It is held to the propeller flange with magnets, and eliminates the need for all other timing angle devices and TDC indicators. Quality made from delrin and tool steel. Greatly simplifies the timing of new magnetos and periodic timing checks.

P/N 12-21545\$34.50

SIDEWINDER SPEED WRENCH



The Sidewinder Speedwrench specialty tool was developed to counter the frustrations of using standard socket wrenches especially in applications where excessive repetitions are required to install or remove long bolts; or where there is not enough resistance involved to allow the ratchet to function; or where there is not enough working space for efficient use of the standard ratchet wrench. The sidewinder can cut work time in half for professional mechanics and aircraft builders. Now being used by major racing teams, the Sidewinder is a revolutionary addition to every tool box.

- 1/4" P/N 12-21109\$22.50
- 3/8" P/N 12-21100\$22.50
- 1/2" P/N 12-21110\$22.50

ENGINE OVERHAUL STAND



This inexpensive engine overhaul stand is ideal for actual overhaul and for storage of engines. Constructed of heavy duty steel, it features three legs which allow it to sit level on uneven floors and comes complete with an adapter spacer block. The stand is 24" tall with made for user installed casters and comes predrilled for Continental A-65 through O-520 series

engines and Lycoming 65 through O-720 engines. A quality engine stand at an affordable price.

P/N 12-21555\$178.95

ENGINE OVERHAUL STAND KIT



The engine stand kit has all of the components to construct an engine stand. Beginning at the top; the engine stand kit includes (1)The top plate. Designed to bolt down the engine flange to the stand. (2) Three legs that are pre-cut to the proper angle. (3)Three spreader bars to hold the base of the stand from spreading apart. (4) Three feet to stabilize the base and allow installation of casters. The kit is ready to weld. 24" tall when finished. P/N 12-01364.....\$114.50

TWISTER DAMAGED NUT & BOLT REMOVERS



These handy Twister tools work with a socket or wrench and removes nuts regardless of the stud length. No chisels, hammers, drilling, or torches are required. No more busted knuckles! The flush face design allows the remover to grip on the smallest of surfaces, and only 3/4" of working space is required. The same set works on both standard and metric damaged bolts and nuts as well as on collar and flange nuts. Made from high quality tool steel.

PART NO.	NUT OR BOLT SIZE	PRICE
12-00151	5/16" or 8 mm	\$8.30
12-00152	7/16" or 10 mm	\$11.00
12-00153	1/2" or 12 mm	\$11.00
12-00154	9/16" or 14 mm	\$11.00
12-00155	5/8" or 15 mm	\$11.00
12-00150	Set of all 5 sizes	\$33.30

TO

TOOLS

LYCOMING BAFFLE SPRING COMPRESSOR



Our top quality Lycoming Baffle Spring Compressor speeds up the removal & installation of cylinder baffle springs. It eliminates the danger of broken or bent cylinder fins caused by use of screwdrivers and punches. This tool is easy to use and features 2 pivot locations for parallel and angle valve cylinders.

P/N 12-30200\$47.30

VALVE SPRING COMPRESSOR



This tool is used to compress valve springs during valve removal & installation. Ergonomically designed for shop and field use and comes with special pivot pin. Features alloy steel construction with nickel plating.

P/N 12-00202.....\$51.50

LYCOMING VALVE SPRING COMPRESSOR



This cast aluminum alloy valve spring compressor fits Lycoming parallel valve and angle valve horizontally opposed engines. An excellent tool at an economical price.

P/N 12-21520\$57.00

DISTRIBUTOR BLOCK SPRING INSTALLATION TOOL



This tool facilitates the proper installation of contact springs on Bendix magnetos. The O' ring locator ring assures proper location of the tool in the contact tower. Features knurled body grip and ball plunger grip. Made of alloy steel.

P/N 12-21510\$71.50

EAR ISLAND REMOVAL TOOL

When substantial quantities of material have to be removed from the exhaust port, it may be necessary to also remove the island around the exhaust stud area. The ear island removal tool and pilot can be used to accomplish this without the use of power tools.

P/N 12-17608\$73.50

ECONOMIZER VALVE SETTING TOOL



The economizer valve adjusting tool is a simple, functional gage that eliminates the hassle of using a depth mic. The tool is precision made to assure required accuracy.

P/N 12-17500\$156.95

LINK® TOOLS LOCKING SOCKET SETS

LINK® extensions and sockets will not pull apart until you unlock them. When you want to separate them, a small pull on the locking device lets the socket or extension fall free. The locking device is similar to those found on air hose couplings, but is a lot easier to lock and unlock.

41-PC. LINK® 3/8" DRIVE SYSTEM SET



The revolutionary 3/8" Drive LINK® System tools are forged from solid steel, with a distinctive chrome finish for outstanding durability and strength.

The set includes: [1] Universal Joint, [1] Unique UniDriver™ Drive, [1] LINK Automatic-Locking Ratchet, [2] Extensors™ (2 and 6-inch), [2] Spark Plug Sockets (5/8 and 13/16-inch), [9] SAE 6-Point Sockets (5/16, 3/8, 7/16, 1/2, 9/16, 5/8, 11/16, 3/4, and 13/16-inch), [11] Metric 6 Point Sockets (8, 9, 10, 11, 12, 13, 14, 15, 16, 17, and 18-mm), [5] Socket Mounted Hex Bits (3/16, 5/16, and 3/8-inch, and 6 and 10-mm), [5] Socket Mounted Torx or Star Bits (T-25, T-30, T40, T45, and T-50), [4] Socket Mounted Screwdriver Bits (5-mm slotted, 9/32" slotted, #1 Phillips and #2 Phillips), and a Case.

P/N 12-00807\$239.00

41-PC. LINK® 1/4" DRIVE SYSTEM SET



LINK® extensions and sockets will not pull apart until you unlock them. When you want to separate them, a small pull on the locking device lets the socket or extension fall free. The locking device is similar to those found on air hose couplings, but is a lot easier to lock and unlock. The new 1/4" Drive Quick-

Lock™ Set comes with 12 pt. sockets in a new custom-fitted carry-case that floats and contains storage space.

The set includes the following 6 Link-Lock™ Drive Tools: [1] Universal joint, [1] All-metal UniDriver® [1] 36-tooth Slide Button Quick Release Positive Locking Ratchet, [3] Extendor™ Extensions (1.5, 3, 6-inch); 16 12-point Sockets: [8] SAE (5/32, 3/16, 7/32, 1/4, 9/32, 5/16, 11/32, and 3/8 inch), and [8] Metric (4, 5, 6, 7, 8, 9, 10, 11 mm); 19 dingle piece machined steel socket bits: [6] Torx (T-8, T-10, T-15, T-20, T-25, T-27), [9] Hex (5/32, 3/16, 7/32, and 1/4 inch, 3, 4, 5, 6, and 7mm), [4] Screwdriver (#0 and #1 Phillips, 5.5 and 6.5 mm slotted); and a custom-fitted Case with storage space.

P/N 12-02840\$219.00

LINK® TOOLS PALM WRENCH & SPEEDER



LINK® extensions and sockets will not pull apart until you unlock them. When you want to separate them, a small pull on the locking device lets the socket or extension fall free. The locking device is similar to those found on air hose couplings, but is a lot easier to lock and unlock. Just the accessory for tight places where there's not much room to turn. Hand spin, then attach your ratchet to

torque down. Don't worry about dropped sockets or bits, the LINK locking mechanism keeps the attachment attached! Not with old fashioned ball bearings, but a space age case-hardened nickel plated steel pin. Or, leave the Palm Wrench on your ratchet and use it as a handy spinner! Made of aluminum and steel. Highly polished and nickel chrome-plated for durability, rust resistance, and beauty. Exceeds 130% of ANSI standards.

2" Palm Wrench/Speeder 3/8-in. DriveP/N 12-00808\$31.90
1-1/2" Palm Wrench/Speeder 1/4" DriveP/N 12-00809 \$22.95

LINK® 1/4" DR. LOCKING ELECTRIC-TOOL ADAPTER

For use with your battery-operated electric drill or screwdriver to always get secure locking and quick speed on your sockets and attachments. One end goes into the chuck of your power tool and the other clicks into a socket, socket-mounted accessory, or other LINK drive tool with the same Quick-Lock technology that gives you Hand-To-Work locking.

P/N 12-00933\$24.85

ENGINE TOOLS

LYCOMING VALVE SPRING COMPRESSOR

 This cast aluminum alloy valve spring compressor fits Lycoming parallel valve and angle valve horizontally opposed engines. An excellent tool at an economical price. P/N 12-21520\$57.00

PRECISE-GAP SPARK PLUG GAPPING TOOL

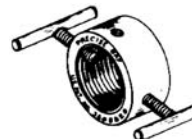
 Precise Gap is a simple tool to gap two-, three- or four electrode 18 mm sparkplugs. Only 2" overall - comfortably handheld. Precision made of stainless steel. "T" handle adjusters move the ground electrodes closer to the center electrode until wire feeler identifies proper gap. Adjusters have fine thread with ball tips for precise movement. Don't buy an inferior imitation at a higher price! P/N 12-11600\$14.70

.016 NOMINAL GAP PLUG GAUGE

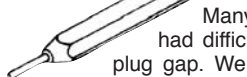
 Many customers have indicated that they have had difficulty obtaining setting wires for gaging the plug gap. We now provide a handy tool at reasonable cost. No need to buy extra gauge sizes that you don't need. Furnished with protective end caps. P/N 12-17100\$7.60

THREAD CLEANOUT TOOL

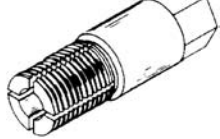
 In servicing spark plugs, a common problem is carbon accumulation in the jug threads. Cleaning these threads regularly can save big money by preventing thread damage and the need to pull the jug and install thread inserts. This specially designed tool works very well to limit this problem. It provides maximum depth penetration and its unique spring action assures that there will be no enlargement of the existing thread pitch diameter. P/N 12-17200\$32.90

COMPASS ADJUSTING TOOL

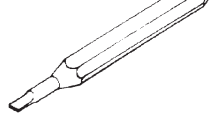
 The compass screwdriver is a great little tool that is totally non-magnetic, but also overcomes the shortcomings of solid brass or aluminum tools. This tool has a nice hex aluminum handle and a stainless steel driver insert. No need to worry about damaging the tip on a frozen compensator screw, and you can also remove the cover plate screws with the same tool. P/N 12-17300\$7.80

THROTTLE SHAFTBUSHING KNOCKOUT

 The throttle shaft bushing removal tool is very competitively priced and will help you avoid a jury-rigged operation that could damage an expensive carburetor body. Now there is no reason not to have one. They are available and affordable. P/N 12-17400\$115.95

ECONOMIZER VALVE SETTING TOOL

 The economizer valve adjusting tool is a simple, functional gage that eliminates the hassle of using a depth mic. The tool is precision made to assure required accuracy. P/N 12-17500\$156.95

SPRING TOOL

 Get a handle on those springs! The "C" shaped tip fit the bend in spring end and won't slip. Can be used to install and remove springs on anything! P/N 12-16945\$8.90

S4-1 RACE REMOVAL TOOL

 A & P mechanics will find this S4 outer bearing race removal tool to be very effective and well priced. Hemispheres held together by the "O" ring are inserted together behind the bearing race. The pilot is then inserted to expand and lock the halves & push out the race. You'll like its simplicity and ease of use. P/N 12-17601\$71.75

S4-2 RACE REMOVAL TOOL

 The S4 magneto drive end inner race removal tool works in conjunction with a standard bearing puller. The split gripper ring fits behind and around the race and is captured in the puller ring by 2 opposing set screws. A groove on the puller ring provides the point of attachment for the puller arms. P/N 12-17602\$106.95

S4-3 RACE REMOVAL TOOL

 The S4 magneto seal installation, inner and outer race installation tool is three tools in one and is proportioned in such a way that it is easily accommodated by most small bench arbor presses. P/N 12-17603\$82.00

TIMING JUMPERS

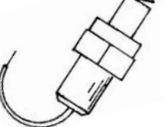
 The timing jumpers are easily used for timing magnetos without removing the breaker box cover. Simply remove the "P" lead and replace with timing jumper. Then hook up timing light leads. These handy devices have proven to be a real time saver and, in some cases, an outright necessity. Bendix S4P/N 12-17700\$15.70
Bendix D2200, D3000, D3200, S6P/N 12-17710\$15.80

LASER MAGNETO TIMER

 The "Laser Timer" mounts on the ring gear at the timing mark for Lycoming engines and beams a bright laser light on the engine case. When the points open on the magneto, and the light beam points to the split in the engine case, the magneto is in time. For Continental engines, a handy adaptor is supplied allowing the "Laser Timer" to mount to the top of the engine block. The laser beams onto the prop backup plate, illuminating user-made timing marks. These aircraft engines run best when the timing is set up according to the manufacturer's specifications. This tool allows the user the timing precision that the engine deserves. The "Laser Timer" is machined out of aluminum stock, and is a quality, precision instrument. The laser is powered by (3) 1.5V batteries that last for years. P/N 12-00740\$59.95

MAGNETO ROTOR BEARING SETTING GAUGE

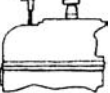
 Determines condition of excess bearing clearance and allows for precise adjustment of new bearings to prevent over or under preload. Available with or without dial indicator. Choice of 3/8-16 or 3/8-24 threaded shaft fittings.

Kit Description	Thread	Part No.	Price
Setting Gauge & Ind.	3/8-16	12-17801	\$84.85
Setting Gauge & Ind.	3/8-24	12-17802	\$84.85
Setting Gauge & Ind.	Both	12-17803	\$137.95
Setting Gauge, No Ind.	3/8-16	12-17901	\$69.85
Setting Gauge, No Ind.	3/8-24	12-17902	\$69.85
Setting Gauge, No Ind.	Both	12-17903	\$103.95

STRUT LIFT JACK

 In many instances, simple tire changing, bearing packing, etc., can be a real problem unless the wheel can be lifted in a safe, secure manner. The strut lift shown accomplishes this easily. A specially designed lift pad securely captures the strut elbow or gear leg. The compact jack can be stored in your toolbox. P/N 12-18000\$104.95

TO

ENGINE TOOLS - SNIPS

PISTON RING COMPRESSOR SET



The most efficient, versatile and dependable tool of its kind on the market. Designed to operate both vertically and horizontally. Fine-tooth ratcheting lock permits bands to be contracted in extremely small increments. Positive lock insures a free hand. Eliminates broken rings during installation. Set includes compressor pliers and the two bands listed in the table.

SetP/N 12-10900\$51.80
 PliersP/N 1114.....\$27.90
 Individual Bands.....\$12.25 Ea.

P/N	Size	Engine Application
1123	3-7/8" to 4-1/8"	Cont. A-65, C-85, C-90, 0-200, 0-300
1125	4-3/8" to 4-5/8"	Cont. E-225, IO-470



PISTON RING FILER

A portable rotary filer. Sizes any make, type, size of ring with machine shop accuracy. Turning crank files both ends at the same time.

P/N 12-11000\$72.00
 Replacement Cutter FileP/N 12-11100\$19.90

Replacement Cutter File



CYLINDER BASE NUT WRENCHES (CONTINENTAL)

Made of top quality tool steel. 12 Point with 1/2" square drive, 13" long.

Set of 4P/N 12-11200.....\$75.80
 or order individual wrenches below.

LYCOMING & CONTINENTAL CYLINDER BASE NUT WRENCHES

Wrench Part #	Size	Engine Application	Price Each
2882	9/16" Hex	C-85, 0-200, 0-300, G0-300, E-185, E-225, 0 & IO-470, IO-360, IO-520	\$18.95
2882-2	1/2" Hex	A-65, C-85, 0-200, 0-300, G0-300, E-185, E-225, IO-360	\$18.95
2882-3	5/8" Hex	A-65, 0-470, IO-520	\$18.95
2882-4	3/4" Hex	No longer used on Cont.; Used on Lyc. 0-390D, D2 and all wide deck Lyc.engines	\$18.95



CYLINDER BASE NUT WRENCHES FOR LYCOMING ENGINES PRE-1960

1/2" Allen Head HexP/N 64942\$48.50
 3/8" Allen Head HexP/N 64943\$48.50

UNIVERSAL CYLINDER BASE WRENCH



Where torque application accuracy is critical these tools meet the requirement. They offer excellent rigidity & surpass other wrenches in overall quality and efficiency. Wrench Type A is for sizes 1/2", 9/16", 5/8", & 3/4" hex nuts. Wrench Type B is for 3/8" & 1/2" internal hex.

Wrench Type A.....P/N 12-11205\$93.50



SNAP RING PLIER KIT

Install or remove retaining rings of the Waldes Tru-Arc type with ease. Quality pliers made of heat-treated steel with vinyl covered handles. Kit includes two pair of pliers and two sets of four replacement tips to handle the most common sizes of both internal and external rings. Furnished in plastic box.

P/N 4440R\$21.90



STRAP WRENCH

Heavy malleable iron body with latex-treated nylon webbing. For gripping and turning of round, hex or square parts without marring the surface. Indispensable tool for use in close quarters where ordinary pliers cannot be used. Tool is 11-1/2" long with 18" strap. Capacity 3". Wt. 1-1/2 lbs.

P/N 3004\$39.95

WISS COMPOUND ACTION SNIPS

Famous for cutting ease, keeping their edge and making clean, sharp cuts. Hardened molybdenum steel blades, serrated jaws and vinyl comfort grips. Capacity 18 gauge (.049") steel. Length 9-3/4". Wt. 14 oz.

- P/N M-1R - Cuts left, from tight curves to straight.....\$17.85
- P/N M-2R - Cuts right, from tight curves to straight.....\$17.85
- P/N M-3R - Cuts straight (or wide curves left or right in light stock). \$17.85



IRWIN OFFSET SNIPS

Irwin offset snips handle virtually every cutting job in sheet metal - linoleum, carpet, tile and other materials. They are easier to use than conventional metal snips, and cut in 3 directions. Irwin snips feature forged steel blades, a unique curved handle for comfortable fit in the hand, and an exclusive pinchpoint wire cutter. They cut in three directions—straight, sharp angles in one direction, and 5" diameter circles in the opposite direction. Irwin offset snips make difficult cuts easy - they can make tight circular cuts, cut easily through corrugated metal, and cut solid and stranded wire. Available in right or left cutting models.

IRWIN (Right Cutting)P/N 12-00187\$15.70
 IRWIN (Left Cutting)P/N 12-00186\$15.70

BULLDOG HEAVY DUTY SNIPS

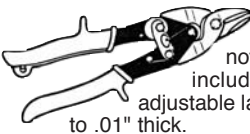

Bulldog Snips are specially designed for more cutting power. They are perfect for notching and trimming heavy stock. Features include serrated blade for positive bite, adjustable lap setting, and full 1" cut length in stock up to .01" thick.

P/N 12-03785\$13.60



LEVER SNIPS

Offset cutting tool, leaves 2 clean, finished edges. 8.5" length, .75 lb.

Model TP133 - (Right hand snip, cuts left & straight) ..P/N 12-00366 ..\$13.30
 Model TP134 - (Left hand snip, cuts left & straight)P/N 12-00367 ..\$13.30



ROBIN OFFSET HEAVY DUTY SNIP

This offset blade design allows the sheet to pass under your hand. The steel forged blades keeps metal from stretching and causing puckering marks along the cut edge. 16 gauge mild steel capacity. 1.63 lbs.

Model TP299P/N 12-00369 ..\$53.25

TO

SPARK PLUG & FILTER TOOLS



CT-415AV GAP SETTING TOOL

A low-cost efficient gap setting tool for closing gaps on massive electrode type aviation spark plugs. May be used as a hand tool, mounted on a bench or held in a vise. Furnished with one adapter for 18mm spark plugs. (P/N GT-204) and one CT-450 gap gauge. Wt. 1-1/2 lbs., 7-1/2" high.

P/N 12-00796.....\$92.95

CT-450 RETRACTABLE GAP GAUGE



High-impact red plastic case contains four sets of accurate, retractable "go" and "no go" wire gauges: 2 sets .015-.019 (.016 Nom.) 2 sets .018-.022 (.019 Nom.) Length: 3-1/2". Wt. 1-1/4 oz

P/N 12-00797.....\$18.90



CT-457 FINE WIRE GAP SETTING TOOL

Designed exclusively for adjusting fine wire electrode sparkplug gap. Two sizes of slots fit all platinum or iridium electrodes for quick adjustment. Red plastic case.

P/N 12-00798.....\$31.95



LEAD-MASTER WRENCH SETS

Reduce time to remove and install sparkplug ignition leads. Permit shortarc turning due to 12-point grip head.

3/4" "T" Handle Box Wrench P/N.....12-00799.....\$104.60
7/8" "T" Handle Box Wrench P/N.....12-00801.....\$81.95
3/4" & 7/8" Open End Box P/N.....12-00802.....\$114.85



CT-907 "PLUG-MATE" MAGNETIC SPARK PLUG SOCKET

A companion tool to the "Plug-Master" and other 3/8" square drive wrenches. Built-in magnet holds plugs. Chrome plated. 3-1/2" long, 7/8" deep hex socket. Wt. 8-1/2 oz.

P/N 12-00804.....\$49.90

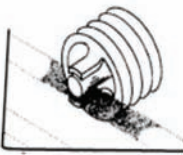

SCREEN CLEAN SPARK PLUG CLEANER

The new Screen Clean tool works great for field cleaning of spark plugs. It is non-abrasive and can be used for several cleanings. Simple to use—just work the bi-fold edge through the gap with several strokes before setting the gap. Actually removes deposits blasting cannot reach.

P/N 12-15610.....\$4.90



SPARK PLUG TRAY

This unique spark plug tray is quality made of PVC plastic. Each holding position has 18 mm thread so that plugs screw in for positive holding. This tray permits simultaneous inspection of either the electrode or barrel end of plugs, protects plugs from damage, and can be stored in any position. Optional carrying strap attaches to ends.

P/N 12-30185.....\$31.00

PLUG-A-LONG SPARK PLUG TRAY



Holds 12 spark plugs each hole stamped with cylinder number also marked top and bottom so each plug can be identified easily, no mix-ups. Plugs can be serviced and returned back to where they were removed. a must for aircraft mechanics. Made from 18 gauge steel. Blue powder coat finish. Dimensions: W=4.0", L=8.0", H=2.6.

P/N 12-00974.....\$22.95



ECONOMY SPARK PLUG GAPPING TOOL

This handy spark plug gapping tool is made from heat treated stainless steel for long life. To adjust the spark plug gap, simply place the tool into plug with ground electrode between the forks, push up on the tool bending the ground electrode closer to the center electrode setting nominal gap of .016".

P/N 12-21352.....\$5.75

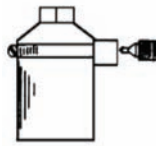

OIL FILTER DRAIN TOOL

This oil filter drain tool permits draining spinon oil filter prior to removal from the engine. Just clamp on to rear of filter with cutter, punch small air bleed at the top of the housing with an ice pick, remove cutter and oil will drain freely in-can or hose-extended funnel.

P/N 08-04200.....\$33.30



MODEL 2500 GAP SETTING TOOL

Complete with accessories, gauges and instructions for use. A precision gap setting tool for all massive electrode sparkplugs. Permits simultaneous adjustment of 2 opposite prongs without removing the spacing gauge.

P/N 12-15500.....\$333.95



CT-446 SPARK PLUG TRAY

Steel tray holds up to 12 plugs. Speeds handling of used or new plugs. Holes numbered to correspond with engine cylinders. Protects against shielding barrel contamination. Dims: 5"H x 8"L x 3.5"W. Wt. 1 lb.

(12 plug tray) P/N 12-00795.....\$37.25
(12 plug tray) P/N 12-00162.....\$56.75

CT-475AV AVIATION SPARK PLUG TESTER



Designed to clean and test all 14 and 18mm massive and fine-wire electrode aviation sparkplugs. Cleaner uses dry-abrasive air blast which quickly and effectively removes conductive deposits. The new "solid state" ignition system produces a very stable ignition test voltage for greater accuracy and reliability. Contains a built-in automatic water trap.

Size: 11.5"H x 16-3/8"W x 12-1/8"D. Requires 125-180 PSI compressed air and 115V 50/60 Hz AC. Power consumption: 35 W. For use with 230V, a 230V power supply and power cord is required (special order).

P/N 12-00794.....\$1,127.00

MODEL 2600A VIBRATOR/CLEANER



Champion now makes it easier than ever to clean heavily lead-fouled spark plugs with this new, improved Vibrator/Cleaner. Each unit is shipped with all accessories required for cleaning fine-wire and 2-prong massive electrode aviation spark plugs. This unit features quick-change cleaning head assemblies, easy and inexpensive replacement of single cutter blades, improved heavy duty top-mounted switch and improved vibrator motor for faster cleaning and maximum durability.

Model 2600A P/N 12-15600.....\$499.00

NO. 91893 ABRASIVE COMPOUND



Complete with accessories, gauges and instructions for use. A precision gap setting tool for all massive electrode sparkplugs. Permits simultaneous adjustment of 2 opposite prongs without removing the spacing gauge. Designed for permanent installation on bench.

P/N 91893.....\$5.40

CHAMPION CT-456A INSPECTION LIGHT



The angled bulb socket is kept out of the viewing field of the magnifier providing a large viewing area. With a 2.75 magnification, it provides an extremely long focal length, ideal for viewing into spark plugs or igniter leads. It can also look into drilled or tapped holes on a part making it easy to spot burrs or foreign matter in items such

as valves & fittings.

P/N 12-00793.....\$59.25

TO

SPARK PLUG TOOLS – OIL CAN CUTTERS

AIRWOLF AFC-470 OIL CAN CUTTER



Every A&P knows the importance of cutting every single oil filter open after an oil change. The problem up to now was oil filters were difficult to open and the tools to open them were expensive. This is no longer the case with the Airwolf AFC-470 oil filter cutter. The AFC-470 is the easiest and quickest way to determine the current health of your engine. The Airwolf AFC-470 oil filter cutter is constructed out of a solid 6" billet of super strong 6061-T6 aluminum, hard anodized to resist scratches and wear. Stainless steel rollers allow the oil filter to spin effortlessly during cutting. And finally, our specially designed razor sharp cutter wheel hardened to 60 Rockwell, will make quick work of opening any oil filter. This filter is designed to last a lifetime. Fits new style oil filters.

P/N 12-00789\$88.95
Replacement Cutting Wheel.....P/N 13-03958\$7.85

ULLMAN UNIVERSAL SPARK PLUG GAP GAUGE



This gap gauge provides easy accurate spark plug adjustment. Features flanged edge for electrode bending and beveled round hole for opening gap. 1-1/2" diameter. Wt.: 0.8 oz. Scaled from .020" to .100". Pewter plating makes the inches more legible for user to read. Also available in metric scale (0.5 mm to 2.4 mm).

Gap gauge (inches)P/N 12-21375\$1.70
Gap gauge (metric).....P/N 12-21380\$1.95

CHAMPION CT-482 SPARK PLUG EROSION GAUGE

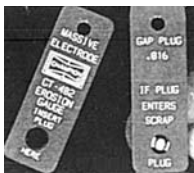

Champion CT-482 spark plug erosion gauge provides an easy, accurate method of determining whether your plugs have reached their maximum wear limit. Simply recap the used plug to .016 nominal, then attempt to insert the electrode assembly through the chamfered hole in the gauge, as shown. Penetration of the hole by the electrode assembly indicates the plug has exceeded its recommended wear limits and should be replaced. The CT-482 is calibrated to reject plugs after their electrodes have eroded to at least one-half their original thickness. Although aviation spark plugs will continue to fire past this wear point, the rate of electrode erosion will increase as a result of non-parallel gaps and reduced sparking area. This leads to intermittent misfire, increased ignition system wear, and possibly costly unscheduled maintenance.

P/N 12-00791\$5.50

"GET THE LEAD OUT" SPARK PLUG VIBRATOR CLEANER

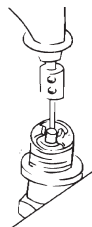

Anyone that cleans a lot of spark plugs knows that a spark plug vibrator cleaner is the only way to go to break up and clean out stubborn lead deposits. A spark plug abrasive cleaner is great for the finish cleaning, but it just won't take care of the lead deposits found down around the plug porcelain. Aircraft Spruce now offers an inexpensive way to professionally clean spark plugs. This 115V vibrator cleaner is small, light weight, easy to use. It is great for the pilot or mechanic that wants to carry one along – just in case. 90 day guarantee.

P/N 12-21355\$23.95/ea.
Extra Cutter Blades..... P/N 12-01147\$0.70/ea.

SPARK PLUG CLEANER



This economical spark plug cleaner cleans any size spark plug without changing the grommet. Features a 2-way valve and comes complete with abrasive powder and bag.

Cleaning Kit-2.2 lbs.P/N TP12\$31.80
Extra Powder-1.8 lbs.P/N TP163\$4.80
Extra Bag-0.06 lbs.P/N TP164\$3.25

CT-709 OIL FILTER ADAPTER WRENCH

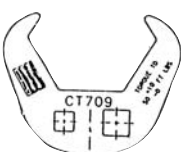

The CT- 709 tool, designed by a professional aircraft mechanic makes the job easier. Manufactured from tool quality steel, the wrench features both 3/8" and 1/2" drives, as well as "flip over" reversibility. For Cessna adapter for 150 Series through 300 Series Aircraft.

P/N CT-709\$73.85



ACS OIL CAN CUTTER

This unit has the capacity of both P/N AFC-470 & 12-21395. It also uses the same replacement blade as the 12-21395. Anodized "Red" for corrosion resistance. Base can be clamped in a bench vise if desired. s black anodized.

P/N 12-01048\$53.65

TEMPEST OIL FILTER CAN CUTTER



This universal cutter from Tempest is easy to use and is a great addition to any toolbox. It's made from high quality aircraft aluminum, making it lightweight and very durable. Works on all aircraft spin-on oil filters. Adapter pin easily removed for 'male' filters.

P/N 12-01392.....\$88.35
Tempest Oil Can Cutter Blades P/N 12-01393.....\$9.90

HAND CRANK OIL FILTER CUTTING TOOL

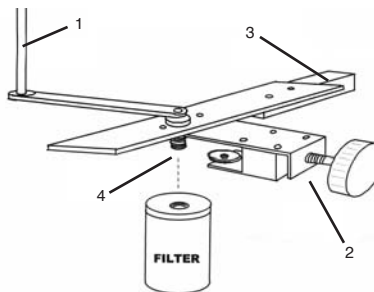

Filter cutting tool assembly instructions:

- #1- Screw handle onto cranking arm with (1) no.10 flat head screw.
- #2- Place cutter assembly to desired position (90° to main tool body left or right) and tighten (2) no.8 flat screws.
- #3- Screw clamp bar for vices (1/2 x 1/2 x 4.0 lg.) in place, with (2) no.10 screws.
- #4- Insert threaded shaft to match thread on filter to be cut.

This tool was designed to eliminate much of the mess that occurs with small handheld oil filter cutting tools. Very simple to operate, it is excellent for individual aircraft owners as well as FBO's and maintenance shops where a lot of filters need to be cut. Simply clamp in a vise, screw on the filter, turn the cutter into the filter and hand crank to open the filter. The rugged construction enables this tool to operate trouble free for years.

P/N 12-00122\$94.50

AVIATION OIL FILTER CUTTER

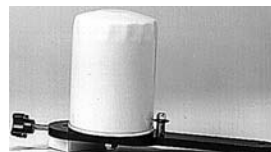

This aviation oil filter cutter will open any size oil filter canisters for your inspection. To use the tool, place the filter in a vice, attach the tool to the top of the filter, and rotate 4 to 6 turns to open the canister. The cutting wheel will stay sharp for about 50 uses, and is easily replaced when dull. The tool is made from

6061 aluminum with a purple anodized finish. The tool is ready to use on any oil filter with a male or female thread.

Oil filter cutterP/N 12-21395\$44.75
Replacement cutting wheelP/N 12-21396\$6.80

OIL FILTER WRENCH



6-inch long, 1-inch box end ratchet wrench with a pre-set torque of 17ft./lbs. for easily and accurately installing oil filters. Fits the hex nut on the end of aviation oil filters.

P/N 12-00758.....\$43.75

OIL FILTER TORQUE WRENCH



The F & M Systems torque wrench will properly torque spin-on oil filters to 17 ft./lbs. This tool is economical, easy to calibrate, simple to use with no adapters required, and fits into spaces with limited access.

P/N 12-01363.....\$43.75

OIL FILTER TOOL

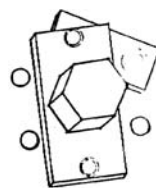

No more stuck filters! No more hammer and chisel or punch to get stuck oil filters off! Fast, safe effective! Easy to use! Saves time and money! How it works: Oil filters get stuck sometimes! That's just a fact of life. All too often that creates a great deal of work and potentially unsafe and expensive work. The "Filter Tool" makes removing a stuck filter easy, safe and it won't damage anything!

P/N 12-16794.....\$12.95

SPARK PLUG TOOLS – OIL FILTER TOOLS

AUTOLITE SPARK PLUG TOOLS

T-240 SPARK PLUG TRAY - Holds up to 12 plugs in numbered holes that correspond to cylinder location.

12-00702\$33.30

T-245 SPARK PLUG EROSION GAGE - Determines wheether plugs have reached their maximum wear limit.

12-00703\$4.20

T-551 SPARK PLUG CLEANER / TESTER (115 VAC) - Tests plugs at 24,000V, and up to 150 psi to simulate engine conditions.

12-00704\$506.00

T-552 SPARK PLUG CLEANER / TESTER (220 VAC) - Tests plugs at 24,000V, and up to 150 psi to simulate engine conditions.

12-00705\$506.00

T-550-10 SPARK PLUG CLEANING TOOLS (qty. 10) - Removes lead deposits and other contaminants, when used with a vibrator cleaner tool (T-559).

12-00706\$27.30

T-554 SPARK PLUG FEELER GAGE - Checks spark plug gap in both decimals of an inch and millimeters

12-00707\$10.70

T-555 SPARK PLUG THREAD CHASER - Unique apring action assures preservation of existing thread pitch diameter.

12-00708\$8.00

T-556 SPARK PLUG THREAD LUBRICANT & ANTI-SEIZE COMPOUND - Helps to prevent galling and lubricates threads during installation.

12-00709\$3.80

SPARK PLUG DEEP SOCKETS

T-557 3/8" drive w/ out magnet 12-01427\$25.00

T-557-1 3/8" drive w/ magnet 12-01428\$29.85

T-558 1/2" drive w/o magnet 12-00712\$15.85

T-559 SPARK PLUG VIBRATOR CLEANER (115 VAC) - Cleans out stubborn lead deposits.

12-00713\$40.40

T-560 SPARK PLUG CLEANER - Complete with powder and bag. Features a 1-way valve.

12-00714\$26.70

T-570 SPARK PLUG TOOL KIT - Includes a spark plug tray (T-240), erosion gage (T-245), cleaning tools (T-550-10), feeler gage (T554), 3/8" drive deep socket with magnet (T-557) vibrator cleaner (T-559), and spark cleaner (T-560).

12-00715\$170.95

CHAMPION CT923 OIL FILTER CUTTER



The new improved CT923 cutter allows oil filters to be cut in either direction. This is a complete tool with no parts or adapters to change. Very easy to use, and will provide a simple effective means of cutting open oil filters. Cutter blades in the CT923 are the same blades that are used in the CT470. Also cuts Champion RBC308 filter used on the Rotax 912 & 914. P/N 12-00923\$143.95

CHAMPION CT924 HOLDER



The CT924 Holder will be a welcome addition to the shop floor to contain spills that might occur during the filter cutting process. It is simple to use and can be used on a machine vise or permanently mounted on a bench top with an optional adapter. P/N 12-00924\$169.95

CHAMPION CT925 MEDIA CUTTER



The CT925 Media Cutter allows the filter media to be cut, removed and analyzed in a very neat and orderly fashion. This tool is designed with safety in mind as it greatly reduces the chance of the operator being cut. Other benefits are timesaving and a filter sample with no contamination compared with previous methods of cutting. The CT925 media cutter adapts to all Champion filters in the marketplace. P/N 12-00925\$526.00

MODEL 7000 OIL FILTER CUTTER



- Accepts both male & female styles of aircraft oil filters, and many automotive sizes.
- Ball bearing rollers make it easy to turn the filter
- Effective design helps insure a straight cut (the filter does not try to spiral off the cutter)
- Heavy duty construction (designed for daily commercial use)
- Aircraft quality aluminum construction
- Replaceable hardened steel cutter wheel
- Contoured knob is easy to turn, even with oily hands
- Accepts oil filters 3 1/8" to 4" in diameter, which includes most aircraft oil filters such as Champion: CH48103, CH48104, CH48108, CH48109, CH48110 AND CH48111
- The cutter may be completely disassembled, and all parts are replaceable.

P/N 13-03145\$89.50

MODEL 7100 OIL FILTER KNOB



- Slips onto the hex of an aircraft oil filter
- Large diameter knob for a strong grip even with oily hands
- Allows many filters to be installed and removed without using a wrench
- Works in tight spaces, you do not have to swing a wrench
- Knob will accept a 3/8" drive ratchet handle to help remove very tight filters (ratchet handle not included)
- Stainless steel core durability (your ratchet goes into stainless steel, not plastic)
- Use a torque wrench to accurately tighten a new filter to the proper torque
- Handle can be used as a base to support the filter, holding it upright so the oil does not spill out.

Color: bright yellow. P/N 13-03146\$30.80

MODEL 7300 OIL DRAINER



Make your oil changes less messy. Drain your oil lines and filter before removing the filter. Works with most Lycoming engines and remote filter installations, and some Continentals. When you drain the oil from the engine, you are only emptying the oil sump. Generally quite a bit of oil remains in the filter and oil lines (if you have a remote mounted filter). A remote mounted filter installation can easily hold a quart of oil in the filter and lines after the engine is drained. This oil will come pouring out when the filter is removed, making a mess in the engine compartment. Cleaning up this mess often takes longer than the actual oil change. The Oil Drainer clamps over the center of the oil filter. A hardened steel rod pierces the filter can and allows the oil to be neatly drained into your catch bucket. After the oil is drained, you can remove the filter with much less mess. P/N 13-03147\$87.50

TO

SPECIALTY TOOLS

ULLMAN MAGNETIC PICK-UP TOOLS



These Ullman pick-up tools with Powercap offer a unique combination of features which make them ideal for work around aircraft. The stainless steel telescoping handle is strong, long, and lightweight, and the comfortable, textured cushion grip keeps handle secure even in wet or oily hands. The head features a compact industrial strength magnet for retrieving heavy objects in tight places. The powercap shields magnet side so that the head can be easily guided past ferrous metal objects. Available in 3 convenient sizes.

- HT-1** lifts 1-1/2 lbs, over 2 lbs with POWERCAP™ telescopes from 6-5/8" to 33-1/4" P/N 12-21385.....**\$8.95**
- HT-2** lifts 3-1/2 lbs, over 5 lbs with POWERCAP™ telescopes from 6-5/8" to 33-1/4" P/N 12-21386.....**\$10.30**
- HT-3** lifts 5 lbs, 10 lbs with POWERCAP™ telescopes from 6-3/4" to 30-1/4" P/N 12-21387.....**\$13.40**



CHP4-L Hook & Pick Set - has picks that are 9.75" long with textured cushion grips. These longer picks are ideal for working in hard to reach awkward areas. P/N 12-00716.....**\$11.40**

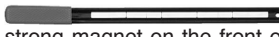

MSR-3 MegaMag Socket Rack - has a strong magnet on the front of the racks that keeps 1/4", 3/8" & 1/2" drive sockets together, organized and ready to use. The magnetic force on the back holds the rack loaded with sockets to most flat metal surfaces. P/N 12-00717.....**\$8.95**



GMC-2 Dual Purpose Tool - contains a MegaMag Pickup Tool that lifts 16 lbs. and a 2.25" Inspection Mirror with a metal base that mounts in seconds and brings hidden areas into full view. P/N 12-00718.....**\$15.50**

EXHAUST PORT RESURFACING TOOL

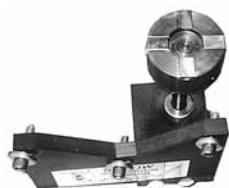

The exhaust port resurfacing tool is designed to recondition port surfaces where no more than .010" of material need to be removed. It is easily bracketed and aligned to the port in reference to the rocker cover surface. Execution of the cutting operation only requires hand power. No air or electrical power is required. Mounting bracket adapters are available for the following engines: A&C series continentals, Lycoming Parallel Valve, Lycoming Angle Valve, others on request

- P/N 12-17605.....**\$298.75**
- A & C Series Continental Bracket P/N 12-17609.....**\$149.00**
- Lycoming Parallel Valve Bracket P/N 12-17610.....**\$149.00**
- Lycoming Angle Valve Bracket....P/N 12-17611.....**\$163.95**
- Cutter Head InsertsP/N 12-17607.....**\$19.00**

EAR ISLAND REMOVAL TOOL - When substantial quantities of material have to be removed from the exhaust port, it may be necessary to also remove the island around the exhaust stud area. The ear island removal tool and pilot can be used to accomplish this without the use of power tools. P/N 12-17608.....**\$73.50**

HANDY MAG RETRIEVAL TOOL

The Handy Mag is the size of a pen and can be carried in a shirt pocket. It telescopes out to an extended length of 32" and the magnet on the tip can pick up objects over 2 lbs. Excellent for retrieving dropped tools or parts in engine compartments or other unreachable areas. Tough stainless steel body.

P/N 12-14550**\$5.85/ea**

EXHAUST DESICCATOR PLUGS FOR EXHAUST STACKS

Quality made polyurethane rubber plug won't wear out and provides a positive seal in the exhaust pipe. Desiccator housing contains interchangeable desiccator canisters. Desiccant never needs to be removed from canister for drying. Removal flag and cap attach to external end of plug when in use. During storage, flag cap fits on desiccator chamber. Limits internal engine damage caused by corrosion. Fits 2" dia. exhaust pipes. Other sizes available as a special order. Minimum special order 5 pieces.

P/N 12-30212....**\$31.70 ea.**

HIGH CAPACITY EXHAUST DESICCATOR

2.5 times the desiccant capacity of previous design. One piece construction allows the dessicant to be contained in the core of the plug. Made of durable high quality urethane rubber that will last almost indefinitely

P/N 12-01057**\$5.85/ea**

GOLDENROD DEHUMIDIFIER

This compact, low-voltage dehumidifier is an ideal way to eliminate dampness and mildew in aircraft which can cause mildew growth in carpet and upholstery and wreak havoc with electrical systems. In stall under the instrument panel or on the deck between seats. If installed in the engine compartment, Goldenrod will eliminate moisture which leads to rust, keep ignition wiring dry, and facilitate cold weather starts. In the hangar, Goldenrod can protect parts, tools, supplies, and components. Operates on standard 110V current 24 hours per day but uses four times less power than a standard light bulb. Safe and effective. Available in four lengths.

Part No.	Length	Watts	Approx. Coverage Up To	Price Ea.
12-30225	12"	8	100 cubic feet	\$39.50
12-30230	18"	12	200 cubic feet	\$42.50
12-30235	24"	15	300 cubic feet	\$45.00
12-30240	36"	25	500 cubic feet	\$47.95

LYCOMING BAFFLE SPRING COMPRESSOR

Our top quality Lycoming Baffle Spring Compressor speeds up the removal and installation of cylinder baffle springs. It eliminates the danger of broken or bent cylinder fins caused by use of screwdrivers and punches. This tool is easy to use and features two pivot locations for parallel and angle valve cylinders.

P/N 12-30200.....**\$47.30**

LAP JOINT JOGGLE TOOL

FOR UP TO .032 ALUMINUM SHEET
To use the Lap Joint Joggle Tool, install washers to adjust joggle set-back from edge of sheet. Start at one end of sheet and pull smoothly along edge to be joggled. Keep back plate of tool firmly and squarely against edge of sheet for smooth and parallel joggle. To break a sheet edge, insert sheet just one bearing depth (.4") then bend down as desired as tool is pulled along edge. Adjustments - For set-back, add or subtract washers. For different material thickness, loosen bolts, spread or close. For use on aluminum sheet up to .032 thickness.

P/N 12-30275**\$33.30**

NON-CONTAMINATING SCRAPER

Our Non-Contamination Scraper is suitable for all airframe scraping operations. It will not contaminate delicate aluminum parts with steel particles which can induce corrosion. It is easily resharpened with a mill file and the .060" thick heat treated aluminum blade is easily replaceable. Features positive wood grip handle.

P/N 12-30205**\$14.00**



TOOLS

ACCU-JIGGER TUBING NOTCHERS



Constructed of 6061T6 hard anodized aluminum extrusions, steel, and cast iron with two 2750 lb. rated roller needle bearings, the Accu-Jigger rigidly holds the holesaw and tube to produce accurate, chatterless cuts. Accu-Jigger, with Single Point Technology, is able to notch tubes that "Fit Right The First Time" as fast as those produced from custom tooling. It employs a flip up Tube End Stop, (2) 1° step, pin settable Angle Indexes and standard bimetal holesaws to accurately

notch the ends of tubes used in aircraft fuselages and engine mounts. Notches tubes up to 1" diameter with up to 2" holesaw at angles from 30 to 90°. Spin Angle settable 0 to 359°. Meant to be driven by 1/2 inch chuck hand drill or mounted to a drill press.

- 1" diameter capacityP/N 12-00377**\$349.95**
- 2" diameter capacityP/N 12-00529**\$479.95**

MAGNETIC BIT CADDY



A non-spill bit holder at your fingertips. 36 individual 1/4" and 5/16" screwdriver bits may be stored in this magnetic-based organizer. Remains solid at any angle placement while holding bits in their respective slots. P/N B1036**\$13.35**

THE SPINNING RATCHET



This tool is a combination tool providing a ratchet wrench for power and a spinning action for speed. All types of accessories can be used with this wrench, such as extensions

on either end, or flexible drives. The drive handle can be removed to make a very compact tool for restricted areas. The ratchet pawl is made from annealed steel to allow it to fail before the ratchet gear as it is a low cost item. The spinning gears are protected by a shear pin that will fail before the bevel gears, again a low cost item replacement, rather replace one or both of the bevel gears if they become over loaded. The pawl is pointed on one to distinguish the on or off motion. 3/8" drive P/N 12-00742**\$39.80**

PNEUMATIC HIGH SPEED DRILL



This heavy duty pneumatic drill will give years of consistent service. Due to speed and design this drill is excellent for deburring or grinding when used with mounted wheels or points. When used with a mounted wire brush it functions as an excellent scaler. As a drill it is adaptable to wood, plastic, rubber, aluminum, brass and sheet metal where contact is brief. Drilling capacity: Steel - 1/8", plastic -3/16", wood - 1/4". Specifications: 13,000-17,000 RPM @ 80-150 PSI. 4-vane motor. Air supply: 4 CFM @ 80 PSI. Wt. 2 lbs. 5 oz. 1/4" chuck. Model 101 ..P/N 12-18700**\$83.75**

THE 3rd HAND WELDING CLAMP



A simple yet rugged tool, The 3rd Hand was designed to hold round or square tubing in place during the welding process. Originally used for aircraft engine mount and airframe fabrication work, it has many other applications. This steel fixture is infinitely adjustable due to its full swiveling clamp. Each model comes with 3 different length arms (3.5", 5.25" & 7.5") Hose

- clamps are not provided.
- Model 01 (for tube size 3/8" - 2.5")P/N 12-00736**\$54.95**
 - Model 02 (for tube size 3/4" - 4")P/N 12-00737**\$59.95**
 - Model 03 (for flat sheets or plates)P/N 12-00747**\$59.95**

MAGNETIZER / DEMAGNETIZER



This versatile tool saves you time and trouble by instantly magnetizing or demagnetizing you tools & parts on the job. Reliable, powerful permanent magnets for a super long life, and its compact size, shatter-proof plastic shell, this tool will fit easily in your tool box. This tool allows easy, precise handling of small steel parts in confined spaces, collects metal items from inaccessible places, leaves 1 hand free for positioning the work piece, demagnetizes instruments & electronics components. Size: 2.1"x2"x1.1". Wt. .22 lb. P/N 12-18700**\$83.75**

TUBING NOTCHER HANDLES 2" O.D.



Ol' Joint Jigger™ quickly notches tubing of up to 2" O.D. in less than 30 seconds. Great for assembling and welding tubing in your garage or workshop. Adjusts in single degree increments to make up to 60 angle notches. Automatic round tubing centering and alignment. CNC machined steel construction. Bi-metal hole saws not included. Use with your 1/2" hand drill. U.S.A. Ship Wt. 9 lbs. P/N RTN100**\$156.95**

RTN-BASE (UNIVERSAL DRILL PRESS MOUNT)

For use with RTN100 only. Allows for set up and dedication of a small drill press for tube notching. Adjustable for out-of-square tables, the RTN-Base also makes it easy to lay the notcher over horizontally, still bolted to the table, to handle long or cumbersome tubing that can't be notched in a vertical position. Minimum requirements: 1/3HP drill press with 3.5" to 4" of travel and 14" from the table or base to the chuck. (Bolts for attachment included) U.S.A. Ship Wt. 3 lbs. P/N 12-00691**\$29.80**

DELUXE ALUMINUM TUBING NOTCHER



Ol' Joint Jigger™ combines precision performance, versatility and comfort for quickly notching tubing of up to 2" O.D. in less than 30 seconds. Enhanced vibration-reducing design and dual-axis base allow for either work bench or drill press mounting to provide the professional or hobbyist with the ultimate in tubing notchers. Laser-engraved protractor allows adjustments in single degree increments to make up to 60° angle notches. Automatic tube centering and alignment. Anodized aircraft-grade aluminum construction. Bi-metal hole saws not included. Use with your 1/2" hand drill or drill press. U.S.A. Ship Wt. 9 lbs. P/N RTN1000**\$229.95**

Description	Part No.	Price ea.
5/8" - 18 Thread Adapter	12-00020	\$6.00
Main Arbor/Shaft	12-00021	\$14.85
For Arbor Support (pair)	12-00022	\$6.00
5/8" Holesaw	12-00023	\$11.40
3/4" Holesaw	12-00024	\$11.25
7/8" Holesaw	12-00025	\$11.25
1" Holesaw	12-00026	\$11.50
1-1/8" Holesaw	12-00027	\$11.50
1-1/4" Holesaw	12-00028	\$11.50
1-3/8" Holesaw	12-00029	\$11.95
1-1/2" Holesaw	12-00030	\$11.95
1-5/8" Holesaw	12-00031	\$11.95
1-3/4" Holesaw	12-00032	\$14.85
1-7/8" Holesaw	12-00033	\$14.85
2" Holesaw	12-00034	\$14.85
Holesaw Assortments		
1", 1-1/8", 1-1/4", 1-3/8", & 1-1/2"	12-00035	\$52.75
1-1/8", 1-1/4", 1-3/8", 1-1/2", & 1-5/8"	12-00036	\$55.50
1-1/4", 1-3/8", 1-1/2", 1-5/8", & 1-3/4"	12-00037	\$57.75
1-3/8", 1-1/2", 1-5/8", 1-3/4", & 1-7/8"	12-00038	\$60.75

PIPEMASTER WELDER'S TOOL FOR CONTOUR FITS



Pipemaster gives aircraft builders the ability to cut a piece of tubing on both ends and have it fit its intended location on the first try. Tedious hours of grinding and misfit joints can be eliminated producing exact welds and stronger airframes. Features spring temper stainless steel pins, aluminum inner shell, and rugged ABS housing. Simply slip over the pipe, push down, transfer and cut, and the tubing is ready to weld. Pipemaster transfers the exact outline of the pipe joint in just seconds. Use for penetration cuts as well.

Part No.	Tubing O.D.	Price	Part No.	Tubing O.D.	Price
12-00102	3/4"	\$43.40	12-00109	1-1/2"	\$54.90
12-00103	7/8"	\$45.00	12-00111	1-5/8"	\$57.65
12-00104	1"	\$45.00	12-00112	1-3/4"	\$59.50
12-00105	1-1/8"	\$46.70	12-00113	1-7/8"	\$61.75
12-00106	1-1/4"	\$48.40	12-00114	2"	\$61.75
12-00107	1-5/16"	\$49.80	12-00116	2-3/8"	\$63.50
12-00108	1-3/8"	\$53.50			

TO

NOTCHERS - SURFACE TREATMENT KITS

JMR NOTCHERS



Made in the U.S.A! • Highest quality, most versatile notcher on the market • Capacity greater than notchers costing 10-20x more! • Notches faster and better than any end mill/belt notcher • Manufactured from bar stock not plate, to increase strength 1.125" induction hardened shaft supported by Timken™ bearings • Custom designed shaft seals prevent bearing/shaft damage • Replaceable hole saw mounting threads • Timken™ thrust bearing increases clamping force (at pivot) while reducing wrench pressure, making angle changes easy • Capable of notching in a 210° arc • 2.5" tube, 2" pipe capacity • Double v-clamp vise allows square to be held flat or corner to corner • Will hold thin wall tube without distortion • May be clamped on tube/pipe to bore holes • Great hole saw life of any notcher (Average 200+ cuts)* • Multiple mounting positions • Designed for prototype and production work • Engraved degrees and stainless steel pointer ensures accuracy • Aluminum bronze acme threaded bushing on clamp

P/N 12-01389.....\$595.00

JMR DIMPLE DIES

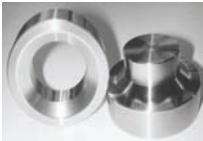

Made in the U.S.A! • Made from heat treated 4142 steel • Will dimple .125" 4130 • All corners radiused • Set of 7 includes fl, 1, 1/4, 1/2, 1, 1.5, 2"

P/N 12-01390.....\$450.00

JMR MANUAL BENDER



Capacity greater than benders costing 10-20x as much!! • Dies available in 120 and 240 • Will bend .250 wall 4130 Tube • Dies are all billet • Follower blocks case hardened .050 min. • Lifetime guarantee against breakage on dies • All pins made from heat treated 4140 • Aluminum bronze bushings at pivot points • Light weight and portable - 110 volt • Built for industrial use, yet affordable enough for everyone!

P/N 12-01388.....\$595.00

MBX KITS AND ACCESSORIES



Patented Technology

MBX Systems are different from conventional surface treatment systems in that MBX Systems are based on several physical principles. Flexible brush-belts are inserted loosely into a cage-like adaptor system and secured with safety arms. The centrifugal force created by rotation causes the brush-belt to tighten and work as if suspended on a cushion of air. Advantages: Vibration-free operation: The vibration of the wire bristles that occurs when the bristles strike the target surface is absorbed by the air-cushion. The bristles re-strike the target surface at rest (without vibration). This achieves the maximum kinetic energy.

MBX brush-belt technology

MBX Belts consist of individual, U-shaped crimped wire bundles anchored in a polyamide fabric. Made of spring steel, the wires have hardened tips that strike the target surface individually during rotation.

Advantages

High safety level: The U-shaped anchor points of the individual crimped bundles prevent wire bristles from being thrown clear. No heat development: Avoid toxic fumes and no smearing during the removal of sticky materials. No grinding: No removal of healthy material, no deformations. Flexibility: High degree of adaptability when working on contoured areas or areas with sharp edges. Optimal performance: Because of their design, each wire tip strikes the target surface twice per rotation. Long service life: Specially hardened wire tips with a hardness up to 68 HRC (Rockwell hardness) provide for a level of hardness never before achieved with conventional brush technology.

MBX Pneumatic drive unit

Easy handling, lightweight - 1.1 kilograms, high torque, safe to use! Specially developed for the MBX brush-belt and MBX Vinyl Zapper systems. The high output rpm of the compressed-air turbine (21,000 rpm) is reduced to 3,500 rpm by means of a planetary gear and toothed belt; torque increases. This gives our MBX pneumatic drive units an optimised power profile. MBX brush-belts and MBX eraser wheels work as a direct extension to the drive shaft, i.e., there is no lateral centre of gravity and MBX drive units operate in-line. Work in hard-to-reach areas or in the removal of tough, thick, sticky materials (e.g. compounding materials, underbody corrosion) with optimal ventilation.



MBX PNEUMATIC STARTER SETS

For the removal of seam sealant, corrosion, paint, vinyl decals, glue on aluminum and alloy.

SET 1

• MP-3500 - MBX Pneumatic Power Tool S (3500 rpm) with adapter system for 23mm belts/31mm rubber eraser. • AA-0011 - Adapter for 11mm wire belts • BS M11X - V2A Wire Belt, Med., 11mm angled tips • BS-F11 - V2A Brush Belt, Fine, 11mm • RE-0023 - Rubber Eraser, 31mm

P/N 12-01394.....\$478.00

SET 2

• MP-350C - MBX Pneumatic Power Tool C (3500 rpm) with noise reduction, air cooling, dust intake, adapter systems for 11mm & 23mm belts/31mm rubber eraser BS-M11X, BS-F11, RE-0023

P/N 12-01395.....\$589.00



MBX ELECTRIC STARTER SETS

For the removal of seam sealant, corrosion, paint, vinyl decals, glue on aluminum and alloy.

ME-3200 - MBX Electric Power

Tool A (3200 rpm) with adapter system for 23mm belts/31mm rubber eraser • AA-0011 - Adapter for 11mm wire belts • BS-M11X - V2A Wire Belt, Med., 11mm angled tips • BS-F11 - V2A Brush Belt, Fine, 11mm • RE-0023 - Rubber Eraser, 31mm

P/N 12-01396.....\$478.00



MBX BRUSH BELTS

MBX Belts are made of a high-performance polyamide fabric - tension resistant up to 440 kilograms. Individual bristles made of spring steel or stainless steel are anchored U-shaped in the flexible polyamide fabric. The materials used for the production of MBX Belts offer top safety and durability due to the high flexibility of the MBX Belts. No clogging - no heat built-up - no grinding. The high masses due to centrifugal force during rotation are absorbed safely by MBX Adapter Systems. MBX Medium have angled tips to create a sandblast effect. 11mm is for especially hard-to-reach-areas such as a 90° angles.

Medium (11 or 23 mm)
For the removal of seam sealant & corrosion on aluminum bodies



BS-M11X MED BLUE 11MM BRUSH
P/N 12-01402.....\$29.50

BS-M23X MED BLUE 23MM BRUSH
P/N 12-01403.....\$29.50

BS-F11 FINE BLUE 11MM BRUSH
P/N 12-01404.....\$29.50

Fine (11 or 23 mm)
For the removal of paint on aluminum bodies.

BS-F23 FINE BLUE 23MM BRUSH
P/N 12-01405.....\$29.50

MBX VINYL ZAPPER



"The rotating toothed eraser wheel", patented For the removal of self-adhesive foils and materials, wide-area decoration, adhesive residue on decorative strips and lettering on OEM-painted surfaces made of metal, aluminium, glass, fibreglass (gel coats) - and most amazing: NO PAINT DAMAGE. The centrifugal force created by rotation makes the MBX Vinyl Zapper work as if suspended on a cushion of air. Advantages: Faster working speeds of up to 3,500 rpm Conventional rubber eraser wheels operate only at circa 1,500 rpm. No paint damage, no smearing despite speeds of 3,500 rpm Toothed wheel design. Easy handling. Vibration-free, smooth running (compare a solid rubber tire with an air-filled tire). Increased performance. The working surface of the MBX Vinyl Zapper is strongly enlarged by the application of pressure to the work surface. This improves performance (compare to a car tire containing only a small amount of air). Long service life Wide construction. Vinyl Zapper 31mm Toothed Wheel Construction Removal of elements such as vinyl decals & DOT tape from metal surfaces, fibreglass, plate glass, wood, aluminum, OEM paint finish.

P/N 12-01406.....\$29.50



STORAGE STATION

For storage of up to 15 wire belts or 9 rubber erasers and one MBX Power Tool (machine, belts, erasers not included).

P/N 12-01399.....\$52.75



CLECOS - HOLE SAWS - TOOL CARTS



SHEET HOLDERS (Cleco Fasteners)

Sheet holders provide the quickest method for holding sheets together for drilling or riveting. Drill the size hole needed for the rivet and insert the sheet holder. The holders listed comprise the most common sizes. Material thickness range 0" - 1/4". Color coded for easy identification. Use with sheet holder pliers.

Part No.	Fastener Size	Color Code	Drill Size	Price Each
M-3/32	3/32"	Cadmium	#40	\$0.43
M-1/8	1/8"	Copper	#30	\$0.43
M-5/32	5/32"	Black	#20	\$0.43
M-3/16	3/16"	Brass	#10	\$0.43

May be assorted. 20% Discount on 50 pcs., 25% Discount on 100 pcs.

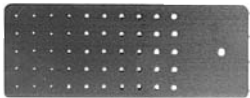

CLECO KEEPER

Fabricated of durable polypropylene, the Cleco Keeper is prepunched to hold up to fifty sheet metal fasteners. Allows the builder to extract and install Clecos from the storage bin to the work with one hand. Compact, the Cleco Keeper measures 8"L x 3"W. Helps eliminate misplaced fasteners and makes inventory of available fasteners quick and accurate. Available in three models to hold 3/32", 1/8", or 5/32" clecos.

- For 3/32" clecos P/N 12-10116 **\$6.40**
- For 1/8" clecos P/N 12-10117 **\$6.40**
- For 5/32" clecos P/N 12-10118 **\$6.40**
- For 3/16" clecos P/N 12-00604 **\$6.40**

CLECO SHEET HOLDER PLIERS



These pliers are designed to grip and actuate all standard sizes of sheet holders and tension clamps. New manufacture.

P/N 12-10105 **\$5.40**

CLECO REVERSE PLIERS



Used in limited access areas. Requires less travel per activation. Model TP74B.

P/N 12-00370 **\$22.40**

PNEUMATIC CLECO INSTALLATION TOOL



This new pneumatic cleco installation tool features a lever throttle, 360° swivel mount, quiet operation, a straight handle, and a 6ft. polyurethane lead hose. The ergonomic design and its ease of

operation allow for quick insertion of all button or plunger type fasteners, including side grips. Wt. 12 oz. Length: 5 1/8". Air Inlet: 1/4".

P/N 12-01120 **\$82.75**

COUNTERBORE

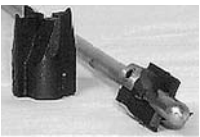

This 5/8" diameter boring tool, has 1/4" diameter pilot. A 10" thread extension is used for boring holes in hard-to-reach places. Primary use is in the installation of the landing gear on the LongEZ and Cozy aircraft. 3/4" bore does not

have 1/4" pilot and must use the pilot received with the 5/8" boring tool.

5/8" dia. w/pilot P/N 12-00219 **\$38.50**

3/4" dia. w/o pilot P/N 12-00220 **\$38.50**

HEAVY-DUTY SHOE SAW ARBORS



Has 1/4" shank.

ARBOR - Use for hole saw sizes 5/8" through 1-3/16". 3 milled flats prevent slipping in chuck. Pilot hole size 1/4".
P/N 49-56-6960 **\$12.45**



QUICK CHANGE ARBOR - Use for hole saw sizes 1-1/4" and larger. The Quick Change 7/16" shank prevents slipping in chuck. Pin drive construction permits fast interchanging of hole saws without removing arbor from chuck. Pilot drill size 1/4".
P/N 49-56-7055 **\$20.95**



STURDY STEP SAFETY PLATFORM

This 22" square platform puts you at the right height so you can work comfortable and safely. Heavy duty construction for years of dependable use. With the Side-Kick, your Sturdy-Step is even more useful. It attaches to the Step in seconds and keeps all of your hand tools and small parts at your fingertips.

Features Holds up to 350 lbs. • Rubber non-slip feet • Meets all of OSHA safety requirements • The top & bottom steps feature perforated tread areas to help prevent slips
P/N 12-00206 **\$89.95**

• Yellow traction markers are also placed on the edge of each step for added safety.

ACCESSORIES FOR THE STURDY-STEP

SIDE KICK TRAY - Tray holds many small tools and allows you to work without making several trips to the work bench or tool box. Attaches to Sturdy-Step with one Phillips head screw and a special clip. Wheels allow you to move the step without lifting or dragging.

P/N 12-00207 **\$77.25**

KICKSTAND - Adds extra stability and increases maximum load capacity to 25 lbs.

P/N 12-00209 **\$9.95**

SPRING-LOADED CASTER SET - Caster assemblies make it easier to move Sturdy-Step without lifting or dragging. Each caster is equipped with a special spring. When you step on the Sturdy-Step, it settles onto the rubber feet, making it a stable, work platform. Set includes 4 caster assemblies, installation hardware & instructions

P/N 12-00208 **\$19.95**

WHEEL AND HANDLE KIT - Attaches to the Sturdy-Step quickly and easily. Wheels allow you to roll the step freely without lifting or dragging; no more back bending, no marred floors. Tip of handle is 44" from ground. Net weight: 7 lbs.

P/N 12-00211 **\$32.30**

EZ REACH TOOL CART



This is a great adjustable height tool cart for mechanics, machinists, electricians, painters and many more uses. Great for around the home repairs or at the job. It adjusts to variable heights (36" to 50") in seconds, becomes a push cart and can be folded up for easy storage or transporting. Has locking caster wheels and weighs only 50 lbs. The payload on the top shelf is 50 lbs. and the bottom shelf's payload is 250 lbs. It comes in 4 different colors (red, blue, yellow and black).

(Red) P/N 12-01335 **\$149.50**

(Blue) P/N 12-01336 **\$149.50**

(Yellow) P/N 12-01337 **\$149.50**

(Black) P/N 12-01338 **\$149.50**

HEAVY-DUTY BI-METAL HOLE SAWS



Milwaukee hole saws provide an economical means of extending the useful range of portable drills, drill presses and lathes. High speed cutting edges welded to steel bodies produce clean, accurate holes All hole saws listed cut to standard 1.25" depth. Order appropriate arbor for use with each size hole saw.

Hole Dia.	Part No.	Use w/Arbor No.	Price
5/8"	49-56-0620	49-56-6960	\$6.85
3/4"	49-56-0750	"	\$6.85
7/8"	49-56-0870	"	\$6.85
1"	49-56-1000	"	\$7.25
1-1/8"	49-56-1120	"	\$7.25
1-3/16"	49-56-1180	"	\$7.25
1-1/4"	49-56-1250	49-56-7055	\$7.25
1-3/8"	49-56-1370	"	\$7.60
1-1/2"	49-56-1500	"	\$8.40
1-5/8"	49-56-1620	"	\$8.85
1-3/4"	49-56-1750	"	\$9.95
1-7/8"	49-56-1870	"	\$9.55
2"	49-56-2000	"	\$9.55
2-1/4"	49-56-2250	"	\$11.95
3-1/8"	49-56-3120	"	\$13.25

TO

TOOLS - CUTTERS

TWO STEP STUD EXTRACTORS



Our Two Step Stud Extractors are the simplest way to remove broken studs and require only 1/8" of the broken stud for removal. Simply tap stud remover on stud or frozen bolt with a hammer or mallet, and then remove stud by attaching a wrench to the hex portion of the remover. Just hammer on and screw out. Built to last from case hardened steel. Stud Extractors available in sizes listed below.

PART NO.	SIZE	PRICE EA.	PART NO.	SIZE	PRICE EA.
76001-76	3/16"	\$21.90	76008-76	5/8"	\$31.10
76002-76	1/4"	\$23.40	76009-76	3/4"	\$34.40
76003-76	5/16"	\$23.80	76010-76	7/8"	\$44.90
76004-76	3/8"	\$20.85	76011-76	1"	\$47.00
76005-76	7/16	\$21.00	76012-76	Set 3/16-1/2"	\$143.95
76006-76	1/2"	\$22.95	76013-76	Set 9/16-1"	\$188.60
76007-76	9/16"	\$31.20			

XTRAKTOR DAMAGED NUT, BOLT, AND STUD REMOVER



There are literally hundreds of uses for the Xtraktor tools. These tools remove any type of rusted, stuck, painted-over or just plain damaged nuts and bolts. They are also great for removing broken off (above flush) or rusted studs. Set 100E, 5 piece tool set, has a grip range of 1/4" to 1/2". Set 200E, 5 piece tool set, has a grip range of 7/16" to 5/8". • Made in U.S.A. 18-30 teeth to generate gripping action • Pass through design for use over long studs • Overlapping tapered design on the inside diameter of the gripping teeth which creates a range of fit from one tool to the next consecutive tool. • Range of fit eliminates the possible need for further rounding off of a damaged fastener to fit the tool. • Patented internal hex design for extreme gripping power. • Tapered design of teeth allows a quick release feature for removing the fastener. • Corners of hex are filled out to SAE Standards. • Tools have been tested to withstand over 300 ft# with an impact wrench. • Tools come in mar-proof holder that fits easily into a toolbox.

Set 100E 5 Piece P/N 12-00950.....\$18.95
Set 200E 5 Piece P/N 12-00951.....\$18.95

THE PRECISION SURE START TOOL

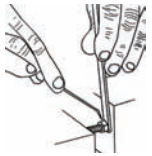

A tool to assist starting a nut onto a bolt in tight fitting areas. Simply screw the nut onto the SureStart tool, place the tool next to the bolt threads and using a small screwdriver or scribe, rotate the nut off of the SureStart tool and onto the threads of the bolt. The aluminum handle may be bent to suit a specific job. Kit accommodates Sizes: #6-32, #8-32, #10-32, 1/4-28, 5/16-24, 3/8-24, 7/16-20 and 1/2-20 nuts. Constructed with aerospace grade aluminum and hardware. Made in the USA Patent Pending

P/N 12-01360.....\$43.80

TAPER PIN REAMERS



Brown & Sharpe Taper pin reamers for installation of AN385 and AN386 aircraft taper pins. Straight shank, straight flute. High speed steel. No. 596 Straight Flute.

B&S Taper No.	Diameter		Flute Length	Part No.	Price
	Small End	Large End			
3	.3099	.4510	3-3/8"	12-09900	\$44.95
5	.4474	.6145	4"	12-10100	\$52.00
6	.4974	.6808	4-3/8"	12-10200	\$60.00

BATTERY BOX MODIFICATION KIT

This new battery box feed-thru insulator design eliminates braided battery straps. It provides positive sealing of the box but makes battery installation a snap. Kit consists of two feed-thru insulators which mount to the box (see "Battery Terminal Tool" illustration below), allowing the cables to pass through to the terminals. Fully FAA-PMA approved. If Bogert's low loss cables (see Electrical section of this catalog) have not been installed, add \$25.00 for cable adapters to price of battery box modification. Always advise aircraft make and model.

P/N 12-16400\$59.00

BATTERY TERMINAL TOOL



This unique tool is designed to provide positive tightening of battery terminals on all popular brands of lead/acid aircraft batteries without over-torquing and without the danger of an electrical short. The tool is made from steel for rugged service and is fully insulated with a rubber hand grip for protection against electrical shorts.

P/N 12-16200.....\$10.60

OLFA ROTARY CUTTER



Ergonomic 45mm rotary cutter features a unique comfortable handle design for both left- and right-handed use. Features include the dual-action safety lock that allows the blade to be locked open for comfort and closed for safety. Accommodates the Olfa straight, wave & pinking blades. The cutter is a rolling razor blade used to cut fabrics into shapes, strips and pieces. Guaranteed forever. Suggested uses: cut fiberglass, composite materials, delicate cloth, fabric, paper, leather, etc. P/N 01-00302.....\$19.90

OLFA STAINLESS STEEL SCISSORS



The OLFA stainless steel scissors (7" overall length) are rapidly growing in popularity in both consumer and industrial applications. Extremely high quality stainless steel blades meet perfectly for precision cutting. The material being cut is held in place by one blade which is serrated, providing positive control. Ideal for use on such varied materials as paper, fabrics, plastic, rubber, & aircraft composites. P/N 01-00303.....\$22.70

OLFA CUTTING TOOLS



OLFA L-2 CUTTER - A sure -grip heavy duty cutter which features a ratchet wheel blade lock & an anti slip rubber grip insert.

P/N 12-00258.....\$6.95



OLFA NOL-1 CUTTER - Heavy duty 'hand setter' utility knife which features a ratchet wheel blade lock. Unique cushion handle provides comfortable grip.

Cutter P/N 12-00257\$8.00
Replacement Blades (5 pack) P/N 12-00261\$4.75



OLFA H-1 CUTTER - Extra heavy Duty sure grip cutter features largest blade available, ratchet lock to prevent slipping, rubber grip insert for positive control, and a rope loop to secure cutter to belt or work table. Cutter.....

P/N 12-00259\$13.50
Replacement blades (5 pack).....P/N 12-00260.....\$5.90



AUTO-LOCK STAINLESS PROFESSIONAL KNIFE

Accommodates both left- and right-handed users. Features locking slide blade, stainless steel handle and built-in pocket clip/blade snapper. A perfect steel cutter where rust is a concern. Lifetime Guarantee.

Cutter.....P/N 12-00339.....\$7.20
Replacement blades (10 pack).....P/N 12-00340\$4.35

ANCHORMATE



If you have ever installed anchor nuts you know what a time consuming and tedious process this can be. Anchormate not only speeds up this task, but also provides the means to obtain a far more accurate positioning and professional looking job. Each Anchormate kit contains hardened drill guides for the four most popular sizes of anchor nuts which will keep your drill bit going straight and true even through the thickest base material. Also unique to the Anchormate is the rivet head countersinking tool which will produce dead accurate countersinks for that perfectly flush rivet. P/N 12-16860.....\$102.95

HINGEMATE



If you have ever struggled trying to get that bolt through the clevis and self aligning bearings on elevators, rudders, and ailerons, you will understand the need for a tool that helps in this task. Designed to firmly hold the grip area of standard AN3 or AN4 aircraft bolts, the hinge mate tool allows the bolt to be inserted through the narrow slot between the fixed and moving sections of the control surfaces, then pushed sideways through the bearing. Once the bolt has started through the clevis and bearing the Hingemate tool can be pulled free, allowing full insertion of the bolt. Also provided are two studs that when inserted into the appropriate hand piece allows either 10-32 or 1/4-28 castle or nylon nuts to be held in alignment with the previously inserted AN3 or AN4 hinge pin and started onto the thread with the aid of a small screw driver. P/N 12-16850.....\$32.75

CUTTERS - GAUGES - RULES



CIRCULAR HOLE CUTTER

Combination round and square shank for chuck or bit brace. With tool steel bit and drill. For cutting metal, wood, plywood, plastic, etc. With 3/16" bit & 11/64" drill. Cuts holes 7/8" to 4" dia.

- #4 Cutter#12-10600\$10.75
- Extra 3/16" Blade#12-10700\$3.30
- Pilot Drills for #4 Cutter #12-10800\$2.35



JEWELERS' SCREWDRIVER KITS

Jeweler's screwdrivers, interchangeable set of 4 blades, 1 awl and 1 handle in snap-button plastic case. Kit #SPC-606

P/N 12-19600\$5.20



SWIVEL HEAD PIN VISE

Has 2 double-end collets with a capacity of 0 to .187 in. or 0 to 3.2mm. Screw chuck tightly holds small drills, burrs, wire & miniature tools.

P/N 92\$7.40



STEEL PROTRACTORS

Graduated from 0° to 180° in opposite directions. 3-3/8" x 2" head. 6 inch adjustable arm set with knurled thumb unit.

P/N 17\$10.90



POCKET CALIPERS

A handy pocket slide caliper with inside and outside reading in 16ths and 32nds. Decimal equivalents on back. 5" rule.

- 16ths & 32ndsP/N 729\$10.50
- 16ths & MMP/N 729MM\$10.90



WIRE STRIPPERS & CUTTERS

Just dial the size and avoid damaging wire, especially when used repetitively. Spring opening jaws can be locked in closed position to protect cutting edges. Made of tool steel, equipped with vinyl cushion grip handles. Individually carded.

P/N 69\$8.70



FEELER GAGES

Blades are made of tempered steel of exacting tolerances. Each blade has its size etched in both decimals of an inch and millimeters. Nickel plated case has knurled locking nut. No. 230 has 26 3x1/2 in. leaves of the following sizes: .0015, .002, .0025, .003, .004, .005, .006, .007, .008, .009, .010, .011, .012, .013, .014, .015, .016, .017, .018, .019, .020, .021, .022, .023, .024 and .025 in. P/N 230\$6.20



REVOLVING PUNCH

This revolving punch is excellent for punching round holes in baffle seal prior to riveting in place. Also works well on leather, plastic, rubber, canvas, & cardboard. Punch sizes: 5/64", 3/32", 7/64", 1/8", 5/32", 3/16".

P/N 72\$8.90



AIRCRAFT BUILDER CALIPERS

Our Aircraft Builder's Calipers feature an easy-to-read dial, 6" length capacity, and measurement in 4 dimensions outer, inner, depth, and step. The dial has .001" graduations for case and bullet measurements. A chart that shows maximum and trim lengths for all popular calipers, plus a fitted case with instructions, are included. Ideal measurement tool for aircraft mechanics and homebuilders. Available in plastic or stainless steel.

- Plastic Calipers.....P/N 12-30215.....\$53.25
- Stainless Steel Calipers.....P/N 12-30220.....\$47.40

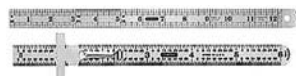

STEEL RULES

Graduated in 10ths and 100th on one side and in Quick-Reading 32nds & 64ths on other side (Grad. No. 5). 6" long, 15/32" wide.

- 6" Long, 15/32" WideP/N 616\$4.15
- 12" Long, 15/32" WideP/N 1216\$7.20



PERMANENT ALNICO MAGNETS

The No. 370-1 pocket magnet is small but powerful. Useful for inspection, retrieving steel parts, screws, etc. No. 370-2 power magnet can be used for lifting, holding, clamping. Has hole in top for attaching to welding jigs, racks, etc.

- No. 370-1 Pocket Magnet, 3/4 oz., approx. 1 lb. pull P/N 370-1.....\$4.95
- No. 370-2 Power Magnet, 2 oz., approx. 13 lb. pull P/N 370-2.....\$9.75



WIRE & SHEET METAL GAUGES

Heavy gauge hardened and tempered tool steel. With gage sizes and decimal equivalents. 3-1/4" diameter; 1/8" thick.

- #20 American Standard Wire Gauge - For gauging non-ferrous wire & metal like copper, brass, aluminum, etc. P/N 20\$18.45
- #21 U.S. Standard Sheet Metal Gauge - For gauging uncoated sheet plate iron and steel. P/N 21\$18.70



RADIUS CHECK

Radius Check is a hand-held tool which can be used to check the radius of parts and panels used in the construction or restoration of aircraft. Also used extensively in the restoration of antique and classic automobiles.

P/N 12-21595.....\$23.95

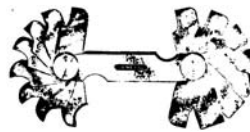

RADIUS OR FILLET GAUGES

16 leaves, especially for checking radius of inside and outside fillets and corners. Checks 1/32 to 17/64" by 64ths.

P/N 432A\$22.50



TRAMMEL POINTS

For measuring or marking distances too great for ordinary dividers. Die cast body with 3 in. needle point legs. Complete with pencil holder to replace leg when so desired. With Fine Adjusting Screw.

P/N 520\$24.95

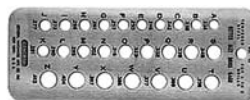

DRILL GAUGES

Used to quickly and conveniently identify drill bit sizes. The Multi-Use Rule and Gage performs 5 separate, distinct functions: drill point gage, bevel protractor, center finder, circle divider and tap and drill gage. The Screw Gage is used to identify machine screws, bolts, wood screws, self-tapping screws and common cotter pin sizes. • No. 14 conforms to government specifications GG-G-86b • General's drill gages are used to quickly and conveniently identify drill bit sizes • Made of heat treated heavy gage steel, machined and ground to close tolerances • Hole sizes and decimal equivalents are permanently etched on the face • No. 12 is 6-1/4" x 2-3/8" wide.

Part No.	No.	Description	Price
12-00517	12	Letter size drills A to Z	\$11.90
12-00518	13	Number size drills 61 to 80	\$13.20
12-00519	14	Fractional size drills 1/16" - 1/2" x 64ths	\$11.30
12-00378	15	Number size drills 1 to 60	\$11.60

TO

DRILLS - TAPS - DIES

AIRCRAFT GRADE SUPER COBALT DRILLS

These super cobalt high-speed jobber length aircraft drill bits feature heavy duty construction to Type J aircraft specifications. Use to drill hard, tough metals, stainless steels, iron based and titanium alloys, and certain plastics. Hardness of cobalt permits speeds 30% over regular H.S.S. drills. Cobalt drills demand rigidly held, positive feed drilling equipment.

Part No.	Drill Size	Qty./Pkg.	Price/Pkg.	Part No.	Drill Size	Qty./Pkg.	Price/Pkg.
12-04212	42	4	\$1.02	12-04221	19	2	\$1.60
12-04213	41	4	\$1.00	12-04222	12	2	\$2.00
12-04214	40	4	\$0.95	12-04223	10	2	\$2.05
12-04215	36	3	\$1.19	12-04224	"D"	1	\$3.20
12-04216	33	3	\$1.79	12-04225	1/8"	3	\$1.33
12-04217	30	3	\$1.35	12-04226	5/32"	2	\$1.52
12-04218	28	3	\$1.37	12-04227	3/16"	2	\$1.77
12-04219	27	3	\$1.51	12-04228	1/4"	1	\$2.70
12-04220	23	3	\$1.59	12-04229	5/16"	1	\$3.95
12-14221	21	3	\$1.59	12-04235	#35	3	\$1.19

12" LONG DRILL BITS

These 12" long drill bits are for use with standard electric drills for the hard to reach jobs.

Drill Size	Size	Part No.	Price
3/32"	(.094")	12-05200	\$3.95
1/8"	(.125")	12-05300	\$4.75
3/16"	(.188")	12-05400	\$5.20
#10	(.194")	12-05500	\$6.95
1/4"	(.250")	12-05600	\$6.70



MALE THREADED DRILL BITS

Male threaded drill bits of high speed steel screw into female spindle of angle drill or snake drill.

Drill Size	10-32 Thread		1/4-28 Thread	
	Part No.	Price	Part No.	Price
#10	12-05701	\$5.20	12-05702	\$2.90
#20	12-05801	\$11.70	12-05802	\$3.35
#21	12-05901	\$6.70	12-05902	\$2.95
#30	12-06001	\$12.20	12-06002	\$2.20
#40	12-06101	\$6.90	12-06102	\$2.20

ANGLE DRILL ATTACHMENT



Quickly connects to any drill chuck. Makes a convenient, inexpensive close-quarter tool. 3/16 drill capacity.

Specify threaded spindle size: 5/16-24 (P/N 12-18503), 1/4-28 (P/N 12-18501) or 10-32 (P/N 12-18502) . \$71.25

Angle Drill w/ Key Chuck (1/4-28 Only) ..P/N 12-18511\$104.95

Angle Drill Kit - Includes tool case, 24" flexible attachment, 4 threaded drills, collet adapter, 90° angle drill, straight drill attachment, 4 collet drills. P/N 12-18505\$174.95



SNAKE DRILL ATTACHMENT

Heavy-duty 90° flexible drilling attachment. Overall length 26". 3 Female threaded spindle sizes.

1/4-28P/N 12-06500.....\$105.95
10-32P/N 12-06600.....\$146.95

W/Key Chuck (5/32"cap.) P/N 12-06800.....\$165.00



CONE JAW CHUCK

Heavy duty yet mini size fits any angle drill or attachment with 1/4" x 28 threads. It's just what you need for close quarter drilling • Capacity from 1/16" to 1/4" • 3/4" length, 0.13 lbs • Wrench included.

Model TP53P/N 12-00245.....\$26.50

ANGLE DRILL COLLET & CHUCK KIT

This 10-piece kit gives you 3 different methods of drilling in tight spots. Each shank is 1/4" x 28 which will thread into most drill spindles that angle attachments and angle drills are supplied with. 0.25 lb. **KIT INCLUDES:** • (4) #20 collets & adapters - drill sizes 11, 21, 30, & 40 • (4) threaded drill bits (1-1/4" length) - drill sizes: 10,21,30,40 • (1) Cone jaw chuck Model TP258P/N 12-00368.....\$68.75

HAND THREAD TAPS

There are three basic types of straight thread taps:

PLUG TAPS – used for ordinary threading and have a 3 to 5-thread chamfer, or relief, at the point.

TAPER TAPS – have 8 to 10 threads chamfered for easy starting and are used for tough threading jobs.

BOTTOMING TAPS – with their short chamfer (1 to 1-1/2 threads), are used where the thread must go to the bottom of the hole. Specify Plug, Taper or Bottoming Tap.



PLUG TAPS				
Die Size	Left-Hand		Right-Hand	
6-32	12-07601	\$4.20	12-07701	\$2.25
8-32	12-07801	\$4.95	12-07901	\$2.25
10-32	12-08001	\$4.10	12-08101	\$2.30
1/4-28	12-08201	\$3.65	12-08301	\$2.05
5/16-24	12-08401	\$4.80	12-08501	\$2.30
3/8-24	12-08601	\$5.80	12-08701	\$3.95

TAPER TAPS				
Die Size	Left-Hand		Right-Hand	
6-32	12-07602	Call for price and availability	12-07702	\$1.84
8-32	12-07802		12-07902	\$1.89
10-32			12-08102	\$1.95
1/4-28	12-08202	special order	12-08302	\$3.05
5/16-24	12-08402		12-08502	\$2.70
3/8-24			12-08702	\$2.80

BOTTOMING TAPS (High-Speed Steel)				
Die Size	Left-Hand		Right-Hand	
6-32		Call for price and availability	12-07703	\$2.85
8-32			12-07903	\$1.89
10-32	12-08003		12-08103	\$2.69
1/4-28	N/A	special order	12-08303	\$3.05
5/16-24	N/A		12-08503	\$3.40
3/8-24	N/A		12-08703	\$3.95

DRILLING & TAPPING SETS



13-Piece drilling and tapping set made from special high speed steel. Contains 6 screw machine length drill bits (Nos. 43, 35, 29, 25, 21 and 7), 16 NC taps (4-40, 6-32, 8-32, 10-24, 10-32 and 1/4-20) and one tap wrench. Choice of 135° split point or spiral point drill bits. Set with Split-Point Drill Bits.

P/N 41095\$23.90

ADJUSTABLE ROUND SPLIT DIES



Die Size	Left-Hand		Right-Hand	
6-32	12-07001	\$8.10	12-07002	\$6.40
8-32	12-07101	\$9.20	12-07102	\$6.30
10-32	12-07201	\$8.60	12-07202	\$6.40
1/4-28	12-07301	\$11.30	12-07302	\$6.50
5/16-24	12-07401	\$11.70	12-07402	\$6.40
3/8-24	12-07501	\$11.40	12-07502	\$6.40

ROUND "KNOCK-OUT" PUNCHES & DIES

Save hours of tedious drilling, sawing, filing and hand-fitting. Produce clean, true holes for sockets, controls, instruments. Cut clean, burr-free holes with these easy-to-use tools. Can be operated by ordinary wrench. One punch required for each hole size.



Punch Size	Model 730 P/N	Price	Model 730 P/N	Punch Size	Price
1/2"	12-20905	\$38.90	1-3/8"	12-20945	\$54.75
5/8"	12-20910	\$37.40	1-1/2"	12-20950	\$68.75
3/4"	12-20915	\$36.20	1-5/8"	12-20955	\$71.50
7/8"	12-20920	\$35.70	1"	12-20925	\$44.30
2"	12-20970	\$101.95			
1-1/8"	12-20930	\$45.20	2-1/4"	12-20975	\$116.95
1-3/16"	12-20935	\$54.75	3-1/8"	12-20980	\$299.50
1-1/4"	12-20940	\$63.75			

Additional Sizes Available. Replace the standard drive screw or nut in the 2-1/4" and 3-1/8" dia. punches with a ball bearing drive for faster, easier hand operation.

Drive for 2-1/4" PunchP/N #304AVBB.....\$25.60
Drive for 3-1/8" PunchP/N #1433AVBB.....\$67.50

DISCOUNT: 12 UNITS - LESS 15% (ASSORTED)

TO

DRILL BIT SETS - CARBIDE DRILLS & BURS

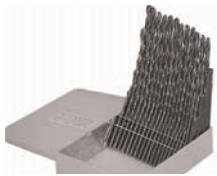

DRILL BIT SET – SIZES 1-60

This jobber length drill bit set includes high speed steel (HSS) drill bits in sizes 1-60. The set comes complete with a steel storage box. Ideal as a pre-drill for tapping of holes and for many other aircraft building applications.
P/N 12-00227\$57.50



29-PC BRITE FLUTE DRILL SET

This 118° point, high speed steel (HSS) drill set performs well in a wide variety of drilling applications. It is recommended for non-ferrous metals, wood, and plastics. Set includes 29 pcs (1/16 to 1/2" in 64ths) in metal index.
P/N 12-00537\$82.25

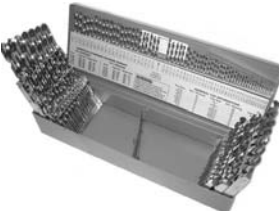

115-PC HSS JOBBER LENGTH DRILL SET

This 118° point, high speed steel (HSS) drill set performs well in a wide variety of drilling applications. It is recommended for non-ferrous metals, wood, and plastics. Set includes 115 pcs (1/16 to 1/2" by 64ths and #1-60 and A-Z in metal index).
P/N 12-00536\$212.95

STRAIGHT FLUTE CARBIDE DRILLS

For use on hardened, treated, and abrasive materials, stainless steel, cryogenic alloys.



Part No.	Cutting Dia. (d ₁)	Decimal Equiv.	Flute Length (l ₂)	Overall Length (l ₁)	Price Ea.
12-00538	13/64	.2031	1-3/16	2-1/4	\$19.50
12-00539	7/32	.2188	1-1/4	2-3/8	\$20.10
12-00540	1/4	.2500	1-3/8	2-1/2	\$22.60
12-00541	9/32	.2812	1-1/2	2-11/16	\$28.10
12-00542	5/16	.3125	1-5/8	2-13/16	\$32.50
12-00543	3/8	.3750	1-13/16	3-1/8	\$39.20
12-00544	1/2	.5000	2-1/4	3-3/4	\$61.25
12-00545	1/8	.1250	7/8	1-7/8	\$14.40
12-00546	9/64	.1406	15/16	1-15/16	\$15.20
12-00547	5/32	.1562	1	2-1/16	\$17.60
12-00551	3/16	.1875	1-1/8	2-3/16	\$18.90

CARBIDE TWIST DRILLS

For use on non-ferrous alloys, cast iron, plastics, aluminum, and highly abrasive materials



Part No.	Cutting Dia. (d ₁)	Decimal Equiv.	Flute Length (l ₂)	Overall Length (l ₁)	Price Ea.
12-00579	1/16	.0625	3/4	1-1/2	\$11.20
12-00580	5/64	.0781	7/8	1-3/4	\$9.95
12-00581	3/32	.0938	1	2	\$8.50
12-00582	7/64	.1094	1-1/4	2-1/4	\$10.50
12-00583	1/8	.1250	1-1/4	2-1/4	\$12.40
12-00584	9/64	.1406	1-3/8	2-1/2	\$13.50
12-00585	5/32	.1562	1-3/8	2-1/2	\$14.95
12-00586	11/64	.1719	1-5/8	2-3/4	\$13.95
12-00547	3/16	.1875	1-5/8	2-3/4	\$17.60
12-00548	13/64	.2031	1-3/4	3	\$14.95
12-00549	7/32	.2188	1-3/4	3	\$17.90
12-00552	15/64	.2344	2	3-1/4	\$19.30
12-00553	1/4	.2500	2	3-1/4	\$24.70
12-00554	17/64	.2656	2-1/8	3-1/2	\$23.80
12-00557	9/32	.2812	2-1/8	3-1/2	\$25.95
12-00558	5/16	.3125	2-3/8	3-3/4	\$29.95
12-00561	11/32	.3438	2-1/2	4	\$34.50
12-00563	3/8	.3750	2-3/4	4-1/4	\$44.80
12-00564	7/16	.4375	2-7/8	4-1/2	\$60.75
12-00567	1/2	.5000	3	4-3/4	\$69.85

Aluminum Cut

Designed for use on aluminum, non-ferrous metals, soft steel, reinforced plastics, and other soft materials.

CYLINDRICAL BALL NOSE CARBIDE BURS

Aluminum Cut. 1/4" shank.

Part No.	Dia.	Flute Length	Price
12-00588	1/4	5/8	\$14.60
12-00589	3/8	3/4	\$19.80
12-00590	1/2	1	\$30.20



CYLINDRICAL CARBIDE BURS

Aluminum Cut. 1/4" shank.

Part No.	Dia.	Flute Length	Price
12-00591	1/4	5/8	\$12.95
12-00592	3/8	3/4	\$16.80
12-00593	1/2	1	\$29.60



ROUND NOSE TREE CARBIDE BURS

Aluminum Cut. 1/4" shank.

Part No.	Dia.	Flute Length	Price
12-00594	1/4	5/8	\$16.80
12-00595	3/8	3/4	\$19.10
12-00596	1/2	1	\$28.10



Medium Tough Cut

Engineered specifically for tough applications. Tough cut insures faster, splinter-free cutting in weld & alloy castings with increased tool life.

CYLINDRICAL BALL NOSE CARBIDE BURS

Medium Tough Cut. 1/4" shank. 6" Long.

Part No.	Dia.	Flute Length	Price
12-00597	3/8	3/4	\$21.00
12-00598	1/2	1	\$28.60



ROUND NOSE TREE CARBIDE BURS

Medium Tough Cut. 1/4" shank. 6" Long.

Part No.	Dia.	Flute Length	Price
12-00599	3/8	3/4	\$20.20
12-00601	1/2	1	\$27.60



14° INCLUDED ANGLE CARBIDE BURS

Medium Tough Cut. 1/4" shank. 6" Long.

Part No.	Dia.	Flute Length	Price
12-00602	3/8	1-1/16	\$23.60
12-00603	1/2	1-1/8	\$30.20



DRILL DOCTOR TRADESMAN BIT SHARPENER

The DD500X Pro Kit combines the Drill Doctor Tradesman sharpener with heavy duty carrying case. Sharpen bits either 118° or the high performance 135° setting and it can turn standard drill bits into self-centering, split point bits. Sharpens bits from 3/32" to 1/2" diameter in about 60 seconds and includes the patented E-Z align system and diamond grinding wheel for sharp precise results. Includes: Sharpener, 1/2" chuck, 110V power cord, carrying case, free video and easy to follow instructions.
P/N 12-00673\$145.95



DRILL SHARP ADAPTER

Designed to allow the sharpening of threaded shank drill bits in the popular Drill Doctor Drill Sharpeners. It will also work in other sharpeners of similar design. Drill lengths from 1/4" to over 2" can be accommodated. No modification to any part of the Drill Doctor is required and switching back to straight shank drill bits is easy. Fits 1/4-28 thread shank drill bits and comes with #30 and #40 Drill guides.
P/N 12-00666\$39.95



TO

ABRASIVE TOOLS & KITS

QUICK CHANGE SANDING & SURFACE CONDITIONING



Power Zirc sanding discs grind down welds and remove sharp edges on all types of metal surfaces. They also apply non-directional finishes to brake rotors, in addition to removing heavy rust and corrosion. Surface Conditioning discs remove baked on gaskets and silicone sealants. They are also used for deburring and polishing sharp edges, as well as paint and corrosion removal. Roloc® is a registered trademark of the 3M Company.

P/N 12-00845.....\$42.60

Qty.	Description	Application
3	2" Power Zirc, Lockit Style Discs, 36 Grit	Weld removal/heavy stock removal.
3	2" Power Zirc, Lockit Style Discs, 60 Grit	Lighter stock removal.
3	2" Power Zirc, Lockit Style Discs, 80 Grit	Blending of heavy scratches.
3	2" Power Zirc, Lockit Style Discs, 120 Grit	Blending and removal of scratches.
3	3" Power Zirc, Lockit Style Discs, 36 Grit	Weld removal/heavy stock removal.
3	3" Power Zirc, Lockit Style Discs, 60 Grit	Lighter stock removal.
3	3" Power Zirc, Lockit Style Discs, 80 Grit	Blending of heavy scratches.
3	3" Power Zirc, Lockit Style Discs, 120 Grit	Blending and removal of scratches.
5	2" Surface Conditioning Discs, Coarse	Gasket/corrosion removal on steel parts.
5	2" Surface Conditioning Discs, Medium	Gasket/corrosion removal on steel & alum.
5	2" Surface Conditioning Discs, Very Fine	Gasket/corrosion removal/scratch blending.
5	3" Surface Conditioning Discs, Coarse	Gasket/corrosion removal on steel parts.
5	3" Surface Conditioning Discs, Medium	Gasket/corrosion removal on steel & alum.
5	3" Surface Conditioning Discs, Very Fine	Gasket/corrosion removal/scratch blending
1	2" Lockit Style Holder Pad with Mandrel	Use w/2" sanding & surface conditioning disc
1	3" Lockit Style Holder Pad with Mandrel	Use w/3" sanding & surface conditioning disc

STANDARD PORTING KIT

A very complete Porting Kit, with a large variety of Cartridge Rolls for a complete porting job. Includes Do-It-Yourself Guide.

P/N 12-00842.....\$34.20



Qty.	Description	Application
2	1" x 1" x 1/4" Flap Wheel, 120 Grit	For porting intake runners.
3 Total	Rotary Stones, Tapered, 60 Grit, (1)3/8" dia., (1)11/16" dia., (1) 1" dia.	Removes large amounts of metal in small areas.
7 Total	Cartridge Rolls, Straight, 1/4" dia., (2) 40 Grit & (5) 80 Grit	Porting heads and intake runners.
7 Total	Cartridge Rolls, Straight, 3/8" Dia., (2) 40 Grit & (5) 80 Grit	Porting heads and intake runners.
7 Total	Cartridge Rolls, Straight, 3/4" Dia., (2) 40 Grit & (5) 80 Grit	For large porting jobs, to remove a great amount of material
7 Total	Cartridge Rolls, Half Tapered, 3/8" dia., (2) 40 Grit & (5) 80 Grit	Remove mat'l in small areas w/greater product endurance
7 Total	Cartridge Rolls, Half Tapered, 5/8" dia., (2) 40 Grit & (5) 80 Grit	Remove mat'l in small areas w/greater product endurance
7 Total	Cartridge Rolls, Full Tapered, 5/8" dia., (2) 40 Grit & (5) 80 Grit	For quick removal of material in small areas of the engine
1	1/4" Dia. Mandrel, 2-3/4" O.A.L.	Use with Cartridge Rolls.
1	1/4" Dia. Mandrel, 4" O.A.L.	Use with Cartridge Rolls.

HAND PADS



Faster, cleaner, and more durable than wire brushes, scrapers and sandpaper. Non-woven nylon pads are pre-cut. They provide conformable, consistent finishes. General Purpose and Ultra Fine Pads may be used with lubricants and solvents. **General Purpose** - Clean up dirty parts in solvent tank • Light corrosion removal on steel and aluminum parts. **Commercial** - An aggressive hand pad for waterbased products only. •Not to be used with solvents. •Heavy duty rust removal and general cleanup **Ultra Fine** - For scuffing in new rod and main bearings. • Light corrosion removal on steel and aluminum parts.

Description	Size	Grain	Color	P/N	Price
General Purpose	6" x 9"	A/O	Maroon	12-00861	\$42.35
Ultra Fine	6" x 9"	S/C	Gray	12-00862	\$40.80
Commercial	6" x 9"	A/O	Green	12-00863	\$37.30
Heavy Duty	6" x 9"	A/O	Tan	12-00864	\$68.50
Hand Pad Holder	-	-	Orange	12-00865	\$14.00

BENCH GRINDER DISCS



Quickly remove carbon from pistons and valve stems. Great for light deburring head bolts and studs. One disc is flexible when run alone. Stack as many discs on at a time for the desired finish and removal rate. Safer than a wire wheel, with a much better finish. The very fine grade Bench Grinder Discs are packaged 10 to a pack, and the medium grade

Bench Grinder Discs are packaged 5 to a pack.

Size	Grain	Grade	Max RPM	P/N	Price
6" x 1/2"	A/O	Very Fine	3,600	12-00847	\$18.80
6" x 1/2"	A/O	Very Fine	3,600	12-00848	\$34.20
8" x 1/2"	A/O	Very Fine	3,000	12-00849	\$31.30
8" x 1/2"	A/O	Medium-	3,000	12-00850	\$26.70

METAL POLISHING KIT



An easy way to polish chrome, aluminum and brass with an electric drill motor. Includes: 4 Felt Discs, 1 Holder Pad, 1 1/4" Mandrel
Metal Polishing Kit (2" Dia.) P/N 12-00843.....\$15.90
Metal Polishing Kit (3" Dia.) P/N 12-00844.....\$18.50

DEBURRING AND FINISHING WHEELS FOR HAND GRINDERS



These abrasive nylon Deburring & Finishing Wheels for hand grinders are very aggressive for metal removal and deburring. They produce a satin-textured finish. New abrasive grain is exposed throughout the wheel's wear, for a consistent quality finish. **High Durability** - The 1"x1" x 3/16" mini wheel is excellent for deburring and blending. • Used with our Cartridge Rolls for porting, our mini wheel supplies a smooth satin finish to ported heads and the intake manifold. • Increases edge life. • Resists loading - smear resistant for uniform final finish. • Conforms to work piece. • Prevents undercutting or gouging.

Size	Density	Grain	Grade	Max RPM	P/N	Price
1"x1"x3/16"	Soft	A/O	Medium	30,000	12-00851	\$24.10
1"x1"x3/16"	Soft	A/O	Fine	30,000	12-00852	\$24.10
1"x1"x3/16"	Soft	S/C	Fine	30,000	12-00853	\$24.10
1"x1"x3/16"	Medium	A/O	Fine	30,000	12-00854	\$33.70
1"x1"x3/16"	Medium	S/C	Fine	30,000	12-00855	\$33.70
1"x1"x3/16"	Hard	A/O	Coarse	30,000	12-00856	\$33.70
1"x1"x3/16"	Hard	A/O	Medium	30,000	12-00857	\$33.70

METAL POLISHING KIT



Save time and money with this generous assortment of our most popular types and grits of Straight Cartridge Rolls, in Coarse, Medium and Fine grades. Keep these Cartridge Rolls in your shop for a variety of hard-to-reach applications. Essential tools for engine porting, including intake manifold, heads and exhaust manifold. Kit includes 1/4", 3/8" and 1/2" cartridge rolls, in 40 and 80 grit, and mandrels. Metal Polishing Kit (3" Dia.) P/N 12-00846.....\$28.90

TO

WISE GRIPS - UNIBITS



**Locking Pliers,
two straight jaws**



**Locking Pliers,
two curved jaws
with wire cutter**



**Long Nose Jaws
with wire cutter**



"C" Clamps

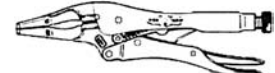

**6 BN Bent Nose
Pliers**



**Locking Hold Down Clamp
with Swivel Tip**



**12 LC Large Jaw
Locking Pliers**

WISE-GRIP STYLE	SIZE	PART NO.	PRICE
Locking Pliers with Two Straight Jaws	7"	12-00196	\$10.20
Locking Pliers with Two Curved Jaws and Wire Cutter	4"	4WR	\$10.70
	5"	12-00194	\$10.30
	7"	12-00189	\$11.50
Long Nose Jaws with Wire Cutter	4"	12-00190	\$11.30
	6"	12-00192	\$13.00
	9"	12-00198	\$14.40
Locking "C" Clamps	6"	12-00188	\$11.80
	11"	12-00195	\$19.00
Bent Nose Locking pliers with Wire Cutter (bent nose provides off angle access to tight places)	6"	12-00193	\$13.90
Large Jaw Locking Pliers, Opens to 3-1/8"	12"	12-00197	\$22.50



TIGHT-FIT DRILL KIT

Space, every inch of it, is at a premium in aircraft design as shape and weight is critical to function. Also, airplanes are riveted together which requires thousands of holes to be drilled in difficult locations without scratching or marring the work surface. So, engineers needed to design a versatile "chuck-less" drill attachment that could reach into very confined areas. The answer was found in putting threads on the shanks of drill bits. The benefits are significant. Threaded drill bits eliminate the need for a chucking mechanism. Freed of this restriction, it is possible to do a wide variety of jobs in places with extreme space limitations (less than 1" x 2"). Chuck slippage is all but eliminated while the precision mating angle between threaded drill and drive spindle insures concentricity. Drill bit change times are reduced, an exact working drill bit length is insured and the chance of marring or scratching the work surface is greatly reduced. The Model 00105 Kit includes: a versatile close-quarter Right Angle Drill Attachment capable of drilling up to 1/4" diameter holes and compatible with all standard power drills, a 6" Threaded Extension for those deep hard-to-reach spots, a Chucking Spud which allows direct use of threaded TightFit® drill bits and extensions with your standard drill motor, five aircraft quality threaded TightFit® drill bits (Short Drill Bit Set, 00133), a Tight Fit® 3-Way Wrench, and is packaged in a red, heavy-duty, blow-molded storage case. **Features:** Attaches to any power drill; Recommended operating speed not to exceed 2500 rpm. • Light weight; Right angle drill weighs 1/3 of a pound and rotates 360 degrees for tight-spot access. • Threaded components allow for fast, easy tool changes; Drill over, under or around obstructions. • Design allows "deep reach" in confined areas; Provides utility of extension drill bit set.

P/N 12-01334\$42.95

ACCESSORIES

- Stub Drill Kit** - 5 Drills 9/16" long in 3/32", 1/8", 5/32", 3/16", 1/4" Dia.
P/N 12-20310\$16.70
- Short Drill Kit** - 5 Drills 1-1/8" long, in same diameters as above
P/N 12-20320\$16.70
- Long Drill Kit** - 5 Drills 2" long in same diameters as above.
P/N 12-20330\$16.70
- Screwdriver Set** - #1 & #2 Phillips bits, small & large slotted bits.
P/N 12-20340\$2.95
- Extension Set** - 4 Extensions in 1/2", 3" 6" & 9" (can be combined for a work length of 18")
P/N 12-20350\$16.70
- Collet Adapter** - Designed to hold all 1/4" shank accessories (counter-sinks, rotary files, sanding drums).
P/N 12-20360\$6.70

DELUXE TIGHT FIT TOOL KIT PROFESSIONAL MODEL



Includes right angle drilling attachment, 6" extension rod, chucking spud, threaded countersink, (6) stub drill bits (9/16" long) & (6) short drill bits (1-1/2" long) in the following diameters: 1/16", 3/32", 1/8", 5/32", 3/16", 1/4". (1) threaded apex socket adapter to fit the angle head & extension rod. (4) screwdriver bits Number 1 & 2 slotted and Number 1 & 2 Phillips. (1) 1/4" threaded collet adapter to fit the angle head, extension rod or spud adapter. (1) 5/16" combination wrench. All above items are packed in a hard blow molded "everything in its place" aircraft mechanic style carrying case. The case even floats when fully packed. There is also a special internal tray for other drills or accessories.
P/N 12-11215.....\$57.25



UNIBIT CARBIDE HOLE CUTTERS

Unlike ordinary hole cutters, Unibit Carbide Hole Cutters cut without hogging, chattering, or vibrating. The aggressive carbide cutting edge holds sharpness for long life. Use them to cut clean, perfectly round holes through steel, stainless steel, aluminum, brass, copper, and many other materials. No center punch is required, and the double ended pilot drill allows for longevity and durability. Available in 16 sizes. Shank size on Hole Cutters 3/4" through 1-1/16" is 3/8", and on cutters 1-1/8" to 1-3/8" shank size is 1/2".

Hole Size	P/N	Price	Hole Size	P/N	Price
3/4"	12-03705	\$31.90			
1-3/8"	12-03750	\$46.80	7/8"	12-03715	\$33.85
1"	12-03720	\$38.30	1-1/2"	12-03760	\$47.00
1-1/8"	12-03730	\$42.70	2"	12-03770	\$48.40
2-1/8"	12-03775	\$53.00	1-1/4"	12-03740	\$74.50
2-3/8"	12-03780	\$48.80			



BLAIR HOLE CUTTER

The Blair hole cutter fits any 1/4" drill and set includes 7 blades (1/4" to 5/8" arbor), pilot and holder. The blades are threaded onto arbor and precise control of the depth of cuts is provided by adjusting screws. Over 3000 holes in sheet metal can be cut by each blade.

Model TP147P/N 12-00243.....\$74.75



UNIBIT STEP DRILL

The UNIBIT Step Drill uses a unique single flute design to drill perfectly round holes in thin materials quickly and with less effort than any other bit on the market today. UNIBIT incorporates cutting steps of progressively larger diameter, making it possible to drill up to 13 different hole sizes with a single bit. Once the desired hole diameter is obtained, the hole is automatically deburred by the cutting edge of the next larger step. UNIBIT #1 drills 13 holes in 1/32" increments from 1/8" through 1/2" and has a shank size of 1/4". UNIBIT #2 drills 6 sizes of holes from 3/16" through 1/2" and has a 3/8" step thickness with a 1/4" shank. UNIBIT #3 drills 9 sizes of holes from 1/4" to 3/4" and has a step thickness of 1/8" with a 3/8" shank.

- UNIBIT #1 Step DrillP/N 12-03700\$16.60
- UNIBIT #2 Step DrillP/N 12-03800\$17.95
- UNIBIT #3 Step DrillP/N 12-03900\$29.95

TO

SHEARS - NIBBLERS



QUICK GRIP BAR CLAMPS

From the makers of Vise-Grip tools comes the amazing new Quick-Grip bar clamp. The unique pistol-grip handle lets woodworkers hold the clamp and adjust jaw pressure with just one hand. One finger unlocks the Quick-release trigger. Features include positive locking action to hold work tight, strong, lightweight high-tech construction, instant adjustable

clamping pressure, large, pliable pads that won't mar work, and a variety of jaw openings. It will "single-handedly" change the way you think about bar clamps!

Part No.	Jaw Opening Size (mm)	Price Each	Part No.	Jaw Opening Size (mm)	Price Each
12-03910	6"/150	\$18.60	12-03940	24"/610	\$34.10
12-03920	2"/305	\$21.70	12-03950	36"/915	\$28.00
12-03930	18"/455	\$22.70			



MICROMETER

For measurements of 0-1", with .001" graduations. Precision-ground hard steel faces. Direct-feel thimble with friction stop and lock nut. Dull chrome finish throughout with black graduations. Decimal equivalents on frame. Zero adjustment requires no wrench. Guaranteed accuracy .0005. P/N MG-1001\$59.25



LONG REACH PLIER KITS

(3) pieces for access into the most demanding applications. Each plier has a full 11" reach. Medium carbon steel, hardened, fully polished. Cushion PVC handles. Leather storage pouch. Model TP942.

P/N 12-00364\$33.20



HOLE DUPLICATORS

(Drill Bushing Type)

Provide an accurate means of drilling duplicate matching holes in overlapping sheets. Hole to be duplicated is drilled through bushing when pilot is in place. \$10.60 ea

PART NO.	PILOT & DRILL SIZE	PART NO.	PILOT & DRILL SIZE
AT532-61 #40	(.098")	AT532-63 #21	(.159")
AT532-62 #30	(.129")	AT532-65 #10	(.194")



DRILL STOPS

Lock on drill with set screw. Regulate hole depth, cushion the breakthrough. Eliminate surface marks & reduce drill breakage.

#40 Drill ..P/N 12-08800.....\$0.95 #30 Drill....P/N 12-08900 ..\$0.95
 #28 Drill ..P/N 12-09000.....\$1.75 #21 Drill....P/N 12-09100 ..\$0.95
 #20 Drill ..P/N 12-09200.....\$0.96 #12 Drill....P/N 12-09300 ..\$1.39
 #10 Drill ..P/N 12-09400.....\$0.95 1/4" Drill....P/N 12-09500 ..\$1.39

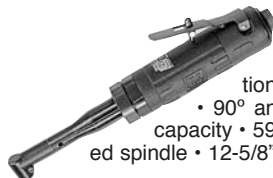

ANGLE DRILL

One of the smallest angle head designs for close-quarter drilling operations. Made in USA. **Features:** • 2800 rpm • 90° angle head • Rear exhaust • 1/4" drilling capacity • 59/64" angle head height • 1/4"-28 threaded spindle • 12-5/8" length • 78DB

P/N 12-00241\$323.95



ADEL HAND "NIBBLING" TOOL

Cuts sheet metal like punch and die. Cuts holes to any size and shape. Start with 7/16" hole then "nibble" to size required. Capacity 18 Ga. steel. Wt. 8 oz.

P/N 12-10400\$16.75

Replacement Punch.....P/N 12-10500.....\$10.45

KETT PORTABLE POWER SHEARS

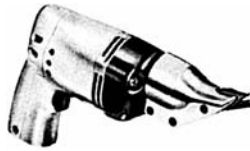

ELECTRIC MODEL K-200 – Extra-powerful 115V, 50/60 cycle AC/DC motor. Heavy-duty bearings & die-cast aluminum cutting head. Tool is UL and CSA approved. 2300rpm. Maximum cutting speed, 180 inches/minute. Wt. 5 lbs. Over-all length, 11.75". Ampere rating, 2.2 amps. P/N K-200.....\$269.95



ELECTRIC MODEL K-442 – Kett's all-purpose 16 gauge power shears cut up to 16 gauge mild steel, cleanly and easily, without burring or buckling the material. These lightweight shears, designed for durability, feature a variable speed motor and fill the gap between Kett's light duty and heavy duty power shears.

P/N K-442.....\$319.95



PNEUMATIC MODEL P-500 – Equipped with air-metering trigger for variable-speed cutting, so that initially the blade can be operated slowly to prevent chattering at start of cut. 2600rpm. Maximum cutting speed, 180" per min. Wt. 3 lbs. Over-all length, 9".

P/N P-500.....\$183.95



PNEUMATIC MODEL PN-1000 – This new pneumatic shear is constructed of lightweight aluminum and features a push-lever variable speed control. Compact, with a smooth, well-balanced grip for one-handed maneuverability and control. Requiring only a 90 PSI air source, the PN-1000 delivers up to 2500 rpm. Cuts 18 Ga. mild steel, flat or corrugated metal with ease. A real time saver.

P/N 1000\$289.95

KB-301 CORDLESS 18GA SHEAR



Kett's powerful 14.4 volt Cordless Shear gives you complete freedom in the shop. Its high torque 2300 SPM motor lets you easily cut 18 gauge mild steel or up to 20 gauge stainless at over 150"/minute. The swivel head gives you precise control as you make straight or contour cuts. The double-cut shearing action leaves a clean burr free edge and won't warp or bend the piece. The lightweight hi-impact thermoplastic housing and aluminum cutting head keep weight down to only 7 lbs. The extended run time NiCad battery recharges quickly and there's room for a spare, and the charger unit, in the handy carrying case. Length: 12-3/4", Weight: 7 lbs.

The kit includes the KB-301 power shear, KB-302 14.4 volt NiCad High Performance battery. KB-303 battery charger and KB-304 carrying case.

Model No.	Description	Part No.	Price
KB-301-K	Cordless Shear Kit #300	12-00117	\$314.95
KB-302	14.4 volt NiCad Battery	12-00118	\$87.50
KB-303	One Hour Battery Charger	12-00119	\$88.25
KB-304	Carrying Case	12-00121	\$37.50



KD440 14GA POWER SHEARS

This lightweight, pistol grip shear cuts 14 gauge mild steel and most grades of stainless to 16 gauge. Double insulated, the KD 440 cuts over 150 inches/minute, leaving a clean, flat sheet, ready to fabricate. Distortions are absorbed in an easily disposed of waste curl, leaving the sheet cool and free of burn, chips, and burrs. The cutting blades are finest high speed steel. (Also cuts sheet metal, Stainless and Plastics)

P/N 12-00676\$298.95

TO

TOOLS

AMP PRO CRIMPER II HAND TOOL



The PRO-CRIMPER II Hand Tool provides the versatility of general-purpose service of general-purpose service tools along with the reliability and ease of use of many premium-grade tools. For versatility, 75 die sets (available separately) are interchangeable, including those for open-barrel contacts and terminals. Additionally, many of these die sets have multiple cavities for crimping a variety of contact or terminal sizes. For reliability, the tool is constructed of durable high carbon steel with extra-strength pivot pins. And, for user convenience, the PRO-CRIMPER II Hand Tool particularly excels. Ratchet control is provided for complete crimp cycling; this helps eliminate partial crimps. Also, an emergency ratchet release allows the user to open the tool jaws at any time during the crimp cycle. To reduce handle force, the linkage was designed to match the forces required to crimp our largest insulated terminal. The result is dramatically less hand force than comparable tools. Also, the angled had and specially designed handles provided comfortable operation. Locator are mounted on pin-and-socket style tools. They help properly locate the contact in the die set, provide a wire stop, and help minimize contact rotation and bending during crimping.

- PROCRIMPER II 58433-3 P/N 12-01379\$98.50
- O-CRIMP DIE 58435-1 P/N 12-01380\$58.75
- HEX CRIMP DIE 58436-1 P/N 12-01381\$46.85
- PIN & SOCKET 58495-2 P/N 12-01382.....\$115.95

STAINLESS BRAIDED HOSE ASSEMBLY TOOLS

Since the invention of stainless braided hose, racers and mechanics have been fighting the problem of installing it into the socket part of the assembly. If your lucky and get a clean cut on the end of that hose, you might get it in. Most of the time a little fuzz appears on the hose end and the battle begins. It is not only time consuming, it can get bloody. This tool is the solution that makes the assembly a snap. Manufactured of a high tech composite, it is virtually indestructible. No need to worry about vise marks or wearing out. Just insert the socket into the tool, twist the hose in, and in less than 10 seconds you have it assembled. You can repeat this several times without recutting the hose end. The tool can pay for itself the first time you don't have to scrap some hose because it got too short trying to clean up the end. You'll be amazed at the amount of time you'll save. **\$57.25**



SMALL KIT

The small kit contains the capsules to install -4, -6, and -8 hose into their respective sockets. To accommodate all the different manufacturer's fittings, spacers and sleeves are required to tighten up some of the sockets within the capsule. In the small kit, only the Russell-4 needs a sleeve. The #8 spacer is used for the -8 sockets. also a special internal tray for other drills or accessories.

P/N 12-01061.....\$73.95



LARGE KIT

The large kit contains the capsules to install -10, -12, and -16 hose into their respective sockets. To accommodate all the different manufacturer's fittings, spacers and sleeves are required to tighten up some of the sockets within the capsule. For the tool to perform at it's best, the socket needs to be a snug fit within the capsule. In the large kit, all the -16s except Russell's require the sleeve and a rear spacer. See the instructions in the case for the proper spacer number. Most of the #10s will use the #10 spacer.

P/N 12-01062.....\$88.85

P-KIT AIRCRAFT WINDOW INSPECTION PRISM KIT



The "P-KIT" (Inspection Prism Kit) is packaged as a completely self contained aircraft window inspection tool kit. It comes in a waterproof lockable case and includes Instructions, Inspection Prism, Coupling Agent and a 6000 Candlepower Flashlight with batteries. It's ready to use to inspect your aircraft windows for possible bolt hole damage. If the "P-Kit" Prism becomes

scratched with use, simply sent it back to the factory and they will refinish it for you free of charge.

P/N 12-01333.....\$225.00

EXPRESS PORTABLE AIRCRAFT VACUUM



The Express Toner/ESD Vacuum provides .3 micron filtration which captures particles that are less than one one-hundredth the thickness of a human hair. This means these vacuums will do a thorough job of cleaning planes of the smallest particulates like mold spores, chemicals, foreign substances or any other microscopic particles that could be hazardous on a plane. Additionally

its light weight (about 6 pounds) makes the Express Vacuum easy to move into and around the interior of an airplane. Plus it is the only product in the market of this nature which is ESD safe, this is of great importance given all the delicate electronic equipment which is found on today's airplanes. Note: Bag is optional and may be purchased separately. Features: 600 Watt Flow Through Motor • 6' ESD safe hose • Crevice tool and brush • 12" Flexneck tool • .3 micron toner cartridge filter • Line filter • 12' power cord • ESD SAFE

- TONER/ESD VACUUM 110V P/N 12-01058\$128.95
- TONER TONER FILTERS 2 PACK P/N 12-01059\$18.95

THE SPINNING RATCHET



This tool is a combination tool providing a ratcheting action for power and a spinning action for speed. All types of accessories can be used with this wrench, such as extensions on either end, or flexible drives. With out the spinning handle attached, it is a very compact tool for restricted areas. The ratchet pawl is made from annealed steel to allow it to fail before the ratchet-gear as it is a low cost item. The spinning gears are protected by a shear pin that will fail before the bevel gears, again a low cost item, replacement, rather than replace one or both of the bevel gears, if they become over loaded. The tool is 3/8" drive. Use your socket accessories, if you do not have a spinning handle purchase one when you buy your new tool.

P/N 12-00742.....\$39.80

KEYLESS DRILL CHUCK



This 3/8 inch square drive works well with the Spinning Ratchet(tm) and with other socket drives; such as the ratchet wrenches, flexible drives, u joints and extensions. Just the tool for getting into tight spaces to tap or other work that requires turning a tool.

P/N 12-01387.....\$25.75

TO

WRENCHES - PLIERS - FEIN MULTIMASTER

FULLY RELEASING TORQUE DRIVER



The MD1F35H is an adjustable driver with a range of 5 to 35 lb. in. Body is constructed of steel and anodize aluminum, has a CNC machined knurled grip and 1/4" male drive and comes packaged in a plastic box. The MDP1F35 is a preset model ideal for repetitive assembly operations.

P/N 12-00530\$209.00

DIAL TYPE TORQUE WRENCH



Dial Type Wrenches provide unmatched reliability, accuracy and durability for applications where torque measurement is extremely critical. Models feature a memory pointer that indicates the highest torque achieved during application of torque. 2% accuracy clockwise and counterclockwise. All wrenches are made in the USA of all steel construction for the highest quality. Both models

come with a plastic storage box and a calibration compliance certificate.

3/8" sq.dr. / 300 lb.in.P/N 12-00531\$217.95

3/8" sq.dr. / 600 lb.in.-50 lb. ft.P/N 12-00532\$199.95

MICROMETER ADJUSTABLE CLICK WRENCH



Engineered, precision bearing surfaces extend the calibrated life of these micrometer torque wrenches to as many as 60,000 cycles or more and ensure the most reliable performance possible. In addition to flawless operation at release, calibration is completely external, unlike traditional mechanism that require disassembly and the replacement of blocks and shims. Both models come with a plastic storage box and a calibration compliance certificate.

3/8" sq.dr. / 30-200 lbs. ft.P/N 12-00533\$197.00

3/8" sq.dr. / 20-100 lbs. ft.P/N 12-00534\$197.00

COMPOUND JOINT HOSE PLIERS



Compound joint allows access in long narrow openings with minimal handle movement. Flush-riveted joints contribute to the tool's narrow profile. Red vinyl grips for comfort & control. Chrome vanadium material for durability & corrosion resistance.

8mm Pliers P/N 12-01344.\$49.95

12mm Pliers P/N 12-01345\$49.95

18mm Pliers P/N 12-01346.....\$49.95

All 3 Set Pliers P/N 12-01347.....\$149.95

LONG REACH COMPOUND JOINT PLIERS



Easily access long narrow openings with minimal handle movement. Longest narrow reach available

13.00" P/N 12-01339.....\$49.95

12.75" P/N 12-01340.....\$49.95

12.62" P/N 12-01341.....\$49.95

All 3 Set P/N 12-01342.....\$149.95

DELUXE HEAT GUN



This handy tool gives you a fast, drum-tight, mirror smooth finish. It's ideal for heat-shrinkable covering films. Get a professional finish with less time and effort. 1-year warranty. **Features:** •Includes removeable wide nozzle •1000W heating power •Heavy-duty fan motor •Textured, composite hand-grip •3-position, hot/cool/off switch •Adjustable air intake baffle •Wt: 15 oz • 5.5' AC power cord w/2-prong plug.

P/N 12-00527\$21.40

SCROOGE CLAMP



By attaching this mechanism to any brace, piece of wood or steel, it can be made adjustable simply by turning the handle. It works like a C-Clamp that will push or pull. It can be used in place of a bar or pipe clamp, and can be made any length by using a 2x2 or 2x4 piece of lumber. Using it, any object or aircraft part can be moved into its exact required position, within a 1/64 of an inch, simply by turning the handle. It is a large turnbuckle with attachment plates at either end. It can be used to plumb walls, square up framing, pull together studs and joist (or push them apart) and straighten warped structural members for fixing in place. It can exert up to 2000 lbs of force with 80 lbs of force on the turnbuckle handle. In most common use, one plate is screwed to a 2x4 and the other to a stud wall or post. The free end of the 2x4 is then nailed or screwed to a joist deck, floor, etc. Maximum travel is 7-3/4".

P/N 12-00636\$22.85

FEIN MULTIMASTER TOOL SET



The MultiMaster is a variable speed oscillating tool that uses a broad assortment of accessory blades to handle hundreds of previously manual tasks. Instead of scraping paint with a putty knife, you use a powered scraping blade. And, instead of sanding tight spaces with your finger, you use one of the varied sanding pads.

The secret is in the oscillation. The MultiMaster doesn't rotate or orbit like other power tools. It oscillates. Oscillation permits you to do extremely fine and delicate work or be more aggressive depending on the accessory blade and material. It's a multi-purpose tool that performs each of its tasks as if it were dedicated to that function alone. Excellent as a sander, a rasp, a polisher, a saw, a scraper, and more.

Kit includes the following:

- MSXe 636-2 MultiMaster, not variable
- Sanding Pad
- 30-pack assorted sandpaper
- Rigid scraper blade
- Flush-cut saw blade
- Screws & washers for sanding pad & blades
- Plastic carrying case

P/N MSX636-2.....\$188.95

ROTO WRENCH — 8 SIZES IN 1

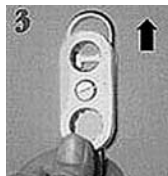

RotoWrench provides 8 sizes in one prostyle box wrench. Change sizes in seconds with unique "spin lock" design. Features 12 gripping teeth to prevent rounded corners, 30° swing arc for tight clearances, slim profile makes RotoWrench easy to store, and hardened chrome-moly steel for lifetime service. Great for working on aircraft, autos, RV's, trucks, bicycles, ATV's watercraft, motorcycles and at home. Lifetime warranty.

Model 10S - includes 8 most common saw sizes: 5/16, 3/8, 7/16, 1/2, 9/16, 5/8, 11/16, & 3/4 in. P/N 12-00522\$14.80

Model 10M - includes 8 most common metric sizes: 8, 10, 12, 13, 14, 15, 17 & 19 mm P/N 12-00523\$14.80

HOSE PINCH-OFF PLIERS



Great for radiator and heater hose, vacuum and fuel lines. Tested to 50,000 cycles without failure for reliable performance. Patented clamping mechanism - No adjustment

needed -- Simply squeeze to lock Cushion handgrips for comfort and control. Available in three sizes. Made in U.S.A.

Hose Pinch-off Pliers 1-1/4" OD Cap.P/N 12-00524\$16.70

Hose Pinch-off Pliers 2-1/2" OD Cap.P/N 12-00525\$23.30

Hose Pinch-off Pliers 3/4" OD Cap.P/N 12-00526\$25.20

HOSE CLAMP PLIERS



Specially designed for applying and removing spring hose clamps. The recesses in the jaws grip the ends of the spring so it cannot slip or twist. Grips with either end or side of jaws for reaching into tight places.

P/N 12-01154.....\$14.25

TO

SAFETY WIRE TWISTERS - SAF-T-BLOKS

MILBAR SAFETY WIRE TWISTERS

Three-In-One Tool: Plier, twister and cutter. Used on wire sizes .060" or less. Grips wire into 30° slip proof angle. One-hand operation. Squeeze, press button and it locks. Squeeze again and it unlocks. Made in USA.

- With Manual Return**
- P/N 1W (Standard Nose) 9" Long ..\$45.70
 - P/N 9W (Tapered Nose) 6" Long\$47.20
 - P/N 11W (Diagonal Nose) 6"L\$49.30
- With Automatic return**
- P/N 1W393 9" Long\$52.00

ECONOMY SAFETY WIRE TWISTERS

These top quality twisting lock pliers with automatic return are economically priced and extremely durable. Features a sharp cutting edge and will twist up to .060" dia. safety wire. Length 9". Foreign made.



Model T-3000.....P/N 12-18900\$22.85

MINI SAFETY WIRE TWISTERS - Same quality construction as T-3000 twisters above, but in small 6" length. Ideal for operation in confined spaces. P/N 12-18910.....\$23.85

19" DEEP-REACH TWISTER EXTENSION

P/N 12-16640.....\$14.95

SPECIALTY TWISTER

An excellent tool for different access situations, this twister provides a deep reach and access to close quarters. Made in U.S.A.



P/N 13W.....\$31.60

SAFETY WIRE TOOL

MFG BY ACS PRODUCTS CO.



Easy one-hand operation. Reaches into tight places, makes a fast, neat twist.

Shatterproof plastic handle. P/N A-013.....\$13.60

POWER TWIST ADAPTER

This new tool attachment provides quick and precise twisting of safety wire using Skil or Black & Decker type cordless screwdrivers. Just attach the adapter to the screwdriver, insert wire and you will have a neat, tight, easy wire twist. Works perfectly in a wide variety of applications (particularly twists in tight spaces). Available exclusively from Aircraft Spruce & Specialty Co.

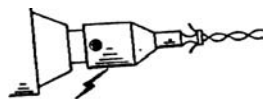

P/N 12-20800.....\$15.75

SAFETY WIRE DRILLING JIG

This tool provides a fast, simple way to drill bolt heads with virtually no broken drill bits. The tool is made of 6061T6 hard anodized aluminum for durability. Fits 3/16" to 5/8" dia. bolts and works on hex head bolts, header bolts, 12 point countersink and Allen head cap screws. Includes drill bushings and two cobalt drills.



P/N 12-16600.....\$59.75

SAFETY WIRE KITS

These kits include professional safety wiring kit for all applications.

Contains 9" automatic standard twister, 6" safety wire twister, made of hardened alloy steel-black oxide finish plus (3) 1/4 lb. spools of annealed stainless steel safety wire. (Sizes: 020-032-042). Model 100 also includes 19" chrome adjustable safety wire twister (for cavity and deep access applications).



Model 200P/N 12-16650.....\$69.50
Model 100P/N 12-00336.....\$78.00

INSTRUMENT MOUNTING HOLE DRILL JIG



Aircraft instrument mounting hole drill jig for standard 2-1/4" & 3-1/8" diameter instruments. Accurate and simple tool to use, drill jig made of hardened steel for long life. P/N 12-00975.....\$31.50

"CENTER IT" HOLE DRILLING JIG



"Center It" is a jig used to drill holes in pipe or tube stock. To use the Center It, simply place it on your drill-press table, run the bit down (with the motor off) to hold the centered jig on the bit, then bolt the jig to the press table. No clamping of the tube is necessary; the angled flats of the jig hold it in a centered position. Your holes are automatically centered on the tube with no center-punching necessary. If the tube is too fat to drill in a single operation, simply turn it over. The device is useful to kitplane builders who have to drill several holes in a single tube or many tubes because no clamping or center-punching of the tube is required. It also makes short work of drilling. P/N 12-20815\$12.90

SAFETY WIRE STARTER KIT



This handy kit enables you to safety wire any nuts or bolts on an airframe or engine. Just place the special washers under the bolt or nut, bend up the small flanges to hold the bolt or nut in place, and then use the tab of the washer to attach the wire to a solid point so the bolt cannot move. This kit works on the same principle as drilled bolts do and is very handy for those flying with an engine that does not have safety wired nuts and bolts. Excellent for use on 2 stroke engines. Package of spare washers includes 6 ea. in 6, 8, & 10 mm sizes.

Safety Wire Starter KitP/N 12-16625\$18.30
Package of 18 Spare Washers.....P/N 12-16626\$6.50

AERO SAF-T-BLOKS

Since the introduction of Saf-T-Bloks in 1981, they've helped thousands of mechanics by taking the headaches and hassle out of drilling safety wire holes in bolts and nuts. This easy to use Saf-T-blok holds the bolt steady after you thread it in to the required depth. You then drill the hole through the center with no risk of misalignment. Saf-T-Blok is available in 4 sizes:

Standard: 1/4-5/16-3/8 USS & SAEP/N 12-15345 ..\$24.80
Metric: 6x1, 8x10, 8x1.25, 10x1.25, 10x1.....P/N 12-15346 ..\$24.90
Aero: 8-32, 10-32, 1/4x20, 1/4x28, 5/16x24.....P/N 12-15347 ..\$24.80
Allen: #8,10,1/4,5/16,3/8P/N 12-15348 ..\$24.80



NUT SAF-T-BLOKS

Designed to enable safety wire holes to be drilled through the head of bolts or through nuts, across the diagonal. Designed to accept up to 3/4" dia. nut. Easy to use. Nut Saf-T-Blok requires that the nut or bolt be placed into the "V" groove, tighten down the holding screw, drill & deburr.

P/N 12-15349 ..\$28.30

QUIKTURN POWER SAFETY WIRE TWISTER

The innovative new safety wire twister will revolutionize the application of safety wire on everything from motorcycle and autoracing to aircraft and NASA space shuttle maintenance. Because of its ease of use, quicker application, and use of a slip clutch to ensure proper tension of the safety wire, it will be invaluable to mechanics worldwide. The wire twister comes with a full 30 day money back guarantee and 5 year warranty on parts and workmanship; Also includes 1 yr warranty on the driver. Includes Safety Wire Twister with rechargeable driver, battery, & charger.

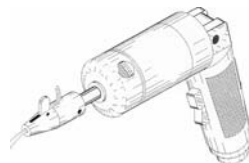

P/N 12-00675\$194.00

DRILL RITE PRECISION DRILL GUIDE

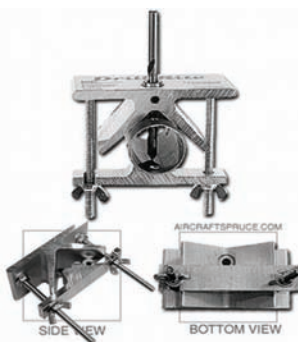

Light and portable, this tool provides straight and true holes every time. Your electric hand drill will perform like a professional drill press. The easy, accurate way to drill any curved surface: Simply place the Drill Rite VGuide™ on any type of pipe or round stock, from 1/2" to 2 1/2" in diameter. Swing the gate closed and lock it down. Insert the proper drill bit in the guide bushing and drill a precisely accurate hole. Includes super hardened drill bushings for popular 3/16" and 1/4" holes for rivets and aircraft hardware. Precision made in the U.S.A. from high quality aircraft grade aluminum.

P/N 12-00836.\$55.95

TO

KLEIN TOOLS

STRIPPER/CUTTERS

Klein wire strippers and cutters cut, strip, gauge and loop a wide range of wire types and sizes. Made of strong, hardened steel with comfortable handles, these tools are durable and long lasting.



11055 Klein-Kurve™ Wire Stripper/Cutter

Solid and Stranded. Double-dipped comfort grips with curved handles, cuts, strips, loops and gauges 10-18 AWG solid wire and 12-20 AWG stranded wire, cleanly shears 6-32 & 8-32 screws, coil spring provides fast, self-opening action. P/N 12-00235\$16.50



11057 Klein-Kurve™ Wire Stripper/Cutter

Solid and Stranded. Double-dipped comfort grips with curved handles, cuts, strips, loops and gauges 20-30 AWG solid wire and 22-32 AWG stranded wire, cleanly shears 6-32 & 8-32 screws, coil spring provides fast, self-opening action. P/N 12-00236\$19.85



11045 Klein 10-18 Wire Stripper/Cutter

Strips 10 to 18 AWG solid wire, easy-to-read wire gauge markings, comfortable handles with cushion ridges. P/N 12-00233\$14.95



11046 Klein 16-26 Wire Stripper/Cutter

Strips 16 to 26 AWG stranded wire, easy-to-read wire gauge markings, comfortable handles w/cushion ridges P/N 12-00234\$15.40



Klein Wire Strippers 6-12

This lightweight Klein-Kurve wire stripper-cutter strips large gauge 6-12 AWG stranded wire and eliminates the need for a skinning knife. The tool clearly shears 6-32 and 8-32 screws and has a serrated pliers nose, which allows the user to pull, grip, and twist wire design and double-dipped textured grips provide control and comfort. P/N 12-01456\$19.20



63020 Klein-Kurve Multi Cable Cutter

Designed with 3 different cutting blades; anvil cutter, a copper curved cutter & a steel cutter. Cleanly shears 6-32 & 8-32 screws, double-dipped comfort grips with curved handles, coil spring provides fast self-opening action. P/N 12-00496\$17.95



63030 Klein 8-1/4" Cable Cutter

Cuts up to 1" diameter aluminum and copper coaxial cable, curved jaws firmly grasp cable, shear-type cutting blades, precision, one-hand shearing action. P/N 12-00497\$32.90



Crimping/Cutting Tool

This tool is designed to crimp insulated and non-insulated 10 to 20 AWG solderless terminals & connectors. It has easy-to-read tool markings to identify the insulated or noninsulated crimping dies. Its tapered nose design works well in tight places and has specially hardened cutter in the nose for quick, clean cuts. Size: 9.75". Lifetime warranty. P/N 12-00698\$30.00

KLEIN ELECTRICIAN TOOL SETS



Designed for beginner and experienced wiremen, these tool sets range in size from a basic 14-piece assortment to the 41-piece comprehensive collection. Each set contains Klein premium products, such as wire stripper/cutters, screwdrivers, and pliers, plus protective eyewear and a pouch or tool bag for toting and storage. Each set offers a cost savings when compared to buying the tools separately. Tools in Electricians sets have standard handles. Tools in Journeyman sets have state of the art dual-material handles which provide a superior grip without sacrificing tool strength or durability.

- 14-Piece Electrician Tool Set.....P/N 12-00819\$176.95
- 18-Piece Journeyman Tool Set.....P/N 12-00821\$239.95
- 28-Piece Electrician Tool Set.....P/N 12-00820\$298.95
- 41-Piece Journeyman Tool Set.....P/N 12-00822\$534.95

PLIERS

Designed and built with exceptional quality standards in a tradition that dates back to 1857. Klein specializes in the making of the world's finest pliers, for the professional. What makes Klein pliers different is induction hardening of cutting edges, pliers head hardness, hot riveting and special handle hardness.

D228-8 Klein 8" Diagonal-Cutting Pliers



High-leverage, standard-bevel cutting knives, with hand-form style plastic-dipped handles. P/N 12-00228\$22.70

D203-6 Klein 6 5/8" Long-Nose Side-Cutting Pliers



Standard cutting knives at hinge, wraps, loops, and cuts, plastic-dipped handles. P/N 12-00229\$19.50

D203-6 Klein 8 5/16" Heavy-Duty Long-Nose Side-Cutting Pliers



Induction hardened cutting knives, greater cutting power, hot-riveted joint, plastic-dipped handles. P/N 12-00230\$29.70

D252-6 Klein 6" Diagonal-Cutting Pliers



All-purpose, heavy duty, tapered nose, induction hardened cutting knives, hot riveted joints, plastic-dipped handles. P/N 12-00231\$24.70

D202-5 Klein 8 5/16" Diagonal-Cutting Pliers



With tapered nose, standard bevel cutting knives, plastic-dipped handles. P/N 12-00232\$21.40



6139 Klein Canvas Zipper Bag

White canvas bag with strong zipper, convenient storage for tools, 7.5" x 12" overall size. P/N 12-00239\$8.60

NUT DRIVERS

The professional requires a number of nut drivers in a variety of sizes and types. Klein drivers feature convenience, comfort and efficiency in use, plus exceptional strength and durability. All Klein nut drivers are made of the highest quality tempered steel, carefully heat-treated for maximum strength.



631 Klein 7-Pc. Cushion-Grip Nut Driver Set

Contains 3/16", 1/4", 5/16", 11/32", 3/8", 7/16", & 1/2" hollow-shaft nut drivers, roll-up plastic storage pouch. P/N 12-00238\$47.30



610 Stubby Nut Drivers

The #610-1/4 & #610-5/16 stubby nut drivers are designed for use in tight spaces and on hard-to-reach fasteners. The tools have cushion grip handles for greater torque and user comfort. Drivers are made for 1/4" & 5/16" hex nut and hex screw sizes. The tool shafts measure 1.5" long and overall 3.5" long. #610-1/4.....P/N 12-00694\$6.90 #610-5/16.....P/N 12-00695\$6.90

TO

TOOLS

KLEIN HOLE SAW KITS



Klein Hole Saws feature bi-metal cobalt construction which allows for heavy-duty cutting; they can cut through studs in one pass. They also have multiple knock-out slots and holes for easy core removal. Carbide grit hole saws work well for cutting abrasive materials and offer a smooth cut with minimal tear-out.

Electrician's Hole Saw Kit - Contains the most popular sizes for basic electrical work. Hole Saws: 7/8", 1-1/8", 1-3/8", 1-3/4", 2", 2-1/2" Arbors: 7/16" (qty.2) P/N 12-00969.....**\$68.55**

Journeyman's Hole Saw Kit - The most frequently used sizes and an arbor extension for hard to reach spots. Hole Saws: 3/4", 7/8", 1-1/8", 1-3/8", 1-1/2", 1-3/4", 2", 2-1/4", 2-1/2" Arbors: 1/4", 7/16" (qty.2), arbor extension P/N 12-00970.....**\$97.70**

Master Electrician's Hole Saw Kit - Includes the most commonly used saws and arbors. Hole Saws: 7/8", 1-1/8", 1-3/8", 1-3/4", 2", 2-1/2", 3", 3-5/8", 4-1/8", 4-1/2" Arbors: 1/4", 7/16" (qty.2) P/N 12-00971.....**\$136.95**

Large Size Hole Saw Kit - Contains necessary sizes to upgrade a basic hole saw kit into a master set. Hole Saws: 3", 3-5/8", 4-1/8", 4-1/2" Arbors: 7/16" P/N 12-00972.....**\$89.70**

SEAT TRACK CLEANER

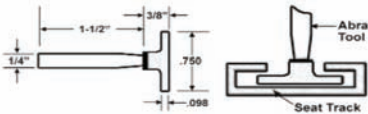

Maintaining adjustable cockpit seats, or passenger seating secured in notched tracks, requires removing the dirt and grit that have

become embedded in the tracks. Rex-Cut Products has developed a thin-profile mounted wheel specially designed to accomplish this job efficiently and safely. The seat track cleaners are manufactured using layers of reinforced nonwoven cotton fiber and abrasive grain which are bonded into discs. When mounted on a die grinder they are able to fit inside the seat tracks. Designed for cleaning all the interior surfaces of the track without having to change discs, one disc will remove caked on sludge, dirt and grit while removing minor burrs and rough edges. The seat track cleaners are non-loading on aluminum and leave superior surface finishes. Available in 54 and 80 grits in aluminum oxide grain mounted on a 1/4 x 1/2" shank.

54 Grit Seat Track Cleaner PN 12-00955**\$6.95**
80 Grit Seat Track CleanerPN 12-00952**\$6.95**

THE TOOL GRIP - TOOL AND CRAFT HOLDER

The Craft Grip is designed to hold tools or other items in the same manner as the Pen Grip. It differs only in the method of attachment. The attachment device is a u-shaped clip that fits over the edge of many surfaces and holds the organizer in place. These cups snap firmly onto the gripping unit. Its most popular uses are car and truck visors, tool boxes, painting easels and many other locations without harming or being permanently attached to the surface

Available in Black or White.

Get a Grip Tool Grip (Black).....PN 12-00953**\$6.95**
Get a Grip Tool Grip (White)PN 12-00954**\$6.95**

THE PEN GRIP - PEN AND TOOL HOLDER



The Pen Grip attaches to almost any surface with double stick tape. Just peel off the backing on the attached double stick adhesive, press firmly onto the surface to which you want it attached and insert your tools. The unique gripping fingers hold all sorts of pens, pencils, & tools in many different positions, even upside down. Like the Tool Grip, The Pen Grip is available in White and Black.

Get a Grip Pen Grip (Black).....PN 12-00961**\$6.25**
Get a Grip Pen Grip (White)PN 12-00962**\$6.25**

GREASE JOINT REJUVENATOR - PROFESSIONAL MODEL



Have you ever tried to push grease in through a grease fitting and couldn't? The Grease Joint Rejuvenator opens clogged grease joints and fittings effortlessly in less than a minute!

- Opens clogged grease fittings & joints
- Cleans and replenishes old and dirty grease fittings
- Loosens dried grease in joints
- Cleans ways and stays in milling machines and lathes
- Lubricates bearings on farm, lawn & construction equipment.

How it works: Remove the piston end and fill the tool with penetrating oil. Then place the end over the grease fitting and tap on the piston head with a hammer until it starts to move down into the tool body. The hydraulic pressure created by tapping on the piston forces the penetrating oil into the grease joint where the blockage is and loosens the old hardened grease (or dirt), flushing the blockage and clearing the way for new grease



Grease Joint Rejuvenator (Pro Model)PN 12-01038.....**\$34.95**

COMPRESSION WHISTLE ALERT



Whistle Alert™ (Rigid)



Whistle Alert™ (Flex)



No more burning your fingers and hands! Just Listen! Insert Whistle Alert™ into any 14mm spark plug hole and bump the engine until you hear the whistle. You are now on the compression stroke!

- Easily find Top Dead Center compression stroke
- Turn engine over from inside the car and listen for the whistle.
- Made of steel and aluminum
- Made and assembled in the USA.

Whistle Alert (Rigid)PN 12-01039**\$15.40**
Whistle Alert (Flex).....PN 12-01041**\$12.25**

ENGINE CALIBRATION & SET-UP KIT



The Engine Calibration & Set-up Kit gives you innovative tools that help eliminate mistakes when setting up mechanical engine timing sequences, timing chains, timing belts, balance shafts and belts, distributor installations and general engine set-up. **Kit includes:**

- Standard 6" (14mm) and Extended 10.75" (14mm) •TDC Indicators
 - Compression Gauge Extension
 - Compression Whistle Alert™
 - Crank Stopper
 - 18mm & 12mm Spark Plug Hole Adapters, extra nipple for compression tube to whistle conversion.
- Engine Calibration & Set-up Kit
PN 12-01040.....**\$69.95**



TO

CABLE CUTTERS - SWAGERS

FELCO CABLE CUTTERS

A cable when crushed or deformed is difficult to use with fittings. These fine quality Swiss made cutters, with unique triangular jaws, never leave a frayed end.



#C-7F CUTTER - Capacity 3/16" diameter and smaller. Length 8". Wt. 10 oz.
P/N C-7F\$43.50



#C-9 CUTTER - Cuts 1/4" steel cable
P/N 12-00179\$103.95

#C-12 CUTTER - Capacity 3/8" diameter and smaller. Length 19". Wt. 3 lbs.
P/N C-12.....\$173.95

#C2A CUTTER - Snub nose for loose cuts. 10% harder blade than C7 for long life and cutting of very hard wire or cable. Opening of tool cuts up to 2mm wire & stranded cable.
P/N 12-00223\$49.60

S & F CABLE CUTTERS



A fine tool made from high quality alloy steel and heat treated for best cutting action and long life of cutting edges. Handles shaped for comfortable grip and minimum cutting effort. Max. capacity 3/16" dia. 1 x 19 cable.

No. 316 Cable Cutter.....P/N 12-18600\$18.95

BENCH MOUNT FOR #316 CABLE CUTTER

This bench mount adds to the versatility of the #316 cable cutter. Mounts with 2 screws to a bench or plate. Fingers can still grip the tool. Easily removed.P/N 12-00674\$3.50

S & F HARD WIRE CUTTER



These quality cutters feature a unique handle design with thick "T" shaped vinyl handle grips for maximum comfort while cutting. Cuts 3/32" maximum diameter music wire, heat treated steel spring wire, stainless or galvanized cable. Produces clean square cuts. Gold iridite finish for maximum rust protection. Length: 6". Wt. 7 oz.

Model No. 093.P/N 12-18605\$19.65

CABLE TENSIO METER



This precision instrument gives accurate readings over a wide range of cable tensions. No preliminary adjustments are necessary. May be used continuously without resetting or checking. Extreme heat or bitter cold does not affect the accuracy of the readings. One instrument is usable on many cable sizes with absolute accuracy. The small size permits entry through small openings and permits accurate readings on cable located in confined areas. The entire operation of testing cable tensions can be done with one hand in a matter of seconds. **Range in Lbs.:** 10-100 on 1/16", 3/32", 1/8"; 15-150 on 5/32", 3/16"; 25-150 on 7/32", 1/4"

T5-2002-101-00\$850.00

BURROUGHS CABLE GAUGE



Easy to use - just squeeze ball handle, put gauge on cable, release handle and read tension on rotation dial. No conversion charts necessary. Tension range: 10-70lbs. for 1/16" cable, 15 - 70 lbs. for 3/32" & 1/8" cable. 50-350 lbs. on 5/32" & 3/16" cable. Only 3-1/4" wide. Fits through inspection hole.

For 1/16", 3/32", 1/8"P/N 12-19200\$149.85
For 5/32", & 3/16".....P/N 12-19210\$187.95

TENSITRON CABLE TENSION METERS



Standard Features of all models: • Easy one-hand operation • No interchangeable parts are needed to adapt to different cable sizes • Memory Lock Pointer holds readings until cleared • Calibration chart affixed to back of meter • Durable and made of non-corrosive materials • Weigh approximately 21 oz. Compact design allows engagement of meter onto cables closely routed along floors, flat surfaces and other minimum clearance areas. Models ACM-100, ACM-200, ACM-300, ACM-400 are compact enough to allow use in limited access panels as small as 4" dia.

Model	Model	Range	Part No.	Price
ACM-100	1/16", 3/32", 1/8", 5/32"	5-100 lb	12-01050	\$689.00
ACM-200	1/16", 3/32", 1/8", 5/32", 3/16", 1/4"	20-200 lb	12-01051	\$790.00
ACM-300	3/32", 1/8", 3/16", 1/4"	40-300lb	12-01052	\$689.00
ACM-400	3/32", 1/8", 5/32", 3/16"	40-400lb	12-01053	\$712.00

ECONOMY NICOPRESS SWAGING TOOLS



NO. 2 SWAGE-IT - For use with sleeves for 1/16", 3/32" and 1/8" cable. Swaging pressure applied by using a wrench to tighten bolts.

Size: 1/2" x 1" x 7". Wt. 1 lb. Cadmium plated.
P/N 12-12000\$16.50

NO. 3 SWAGE-IT - For use with sleeves for 1/8", 5/32", 3/16" and 1/4" cable. Same design as No. 2 tool but larger. Size: 3/4" x 1-1/2" x 14". Wt. 3-1/2 lbs.
P/N 12-12100\$36.50

SWAGE-IT RIGGING KIT



This Swage-It rigging kit contains everything you will need for rigging and emergency repairs of Nicopress sleeves on cables. Includes the #2 Swage-It tool for 1/16", 3/32" and 1/8" sleeves, 1/2" extension wrench for use on the #2 tool and a #316 cable cutter. Size: 4-1/2" x 9". Packaged in a clear plastic tube with vinyl caps to better protect tools.
P/N 12-12200\$46.30

NICOPRESS TOOLS - NO. 1 SWAGER



No. 1-SC Hand Swager - Multi-compression hand swager with cable cutter. Swages 1/16", 3/32", 1/8", 5/32", and 3/16" oval and stop sleeves, plus 7/32" stop sleeves, for a total of 11 sizes plus the ability to cut up to 7/32" diameter aircraft quality steel cable. A tool with a dozen functions. 26 inches long, weighs 6.5 pounds.

P/N 12-12400\$221.95

LOCOLOC HANDSWAGING TOOL

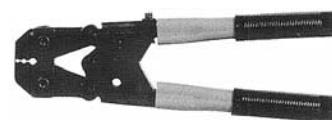

This small hand swager does a great job of swaging small sleeves in sizes 1/32", 3/64", 1/16", and 3/32". The tool is fully adjustable and is preset to gauge at the factory, will swage copper and aluminum sleeves and the ratchet mechanism will not release until swage is complete. Instructions and swage gauge included.

P/N 12-00222\$102.95

ELECTRICAL CABLE/CONNECTOR CRIMPING TOOL



Over the last few years operational personnel have had occasion to crimp from AWG size #8 to 4/0 heavy duty cables to various large electrical power lugs (stud size 3/16 to 1/2 inch), to electrical systems including heavy duty 18 wheel tractor trailer units, aircraft, boats, trailers of all kinds, industrial building electrical systems, electric home repair, farm equipment, etc.

P/N 12-01063.....\$94.00

GO-NO GO SLEEVE GAUGE

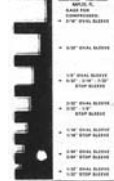

When the proper slot in the gauge slips over the compressed area of the sleeve after swaging then your swage is satisfactory. If the proper slot does not fit over the compressed area of the sleeve after swaging then your tool is out of adjustment and your cable assembly will not hold the rated breaking strength of the cable which should be the result when oval sleeves are used to form a loop or eye in a cable assembly. GA-1P: Gauges all swages performed on 1/32", 3/64", 1/16", 3/32", 1/8", 5/32", and 3/16" oval and stop sleeves.

P/N GA-1P\$10.50

KEARNEY SWAGER

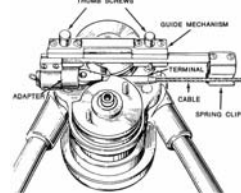

This portable, hand-operated roll type swaging machine will swage MS type terminals onto galvanized and stainless steel cables from 1/16" diameter up to and including 3/16" diameter. Includes machine, a full set of roll dies, terminal gauges and feed guide adapters & instructions in a steel carrying case. Wt. 95 lbs. New manufacture. All replacement parts available. Special order

P/N M1-K.....\$5,994.00

FLYING WIRE TENSIO METER



This tool is used for setting the tension on flying wires from 1/4" - 1/2". Tension

ranges from 200 lbs. to 2400 lbs. Can also be used for setting drag, anti-drag wire tension. Ideal for use on Stearmans, Wacos, and Pitts, etc. To use this tool you will need a torque wrench.

P/N 12-12500\$226.00

TO

SPECIALTY TOOLS - DEBURRING TOOLS



DEBURRING TOOL

Utilizes a twist-of-the-wrist action for deburring holes and radii. Curved blade automatically follows all contours. Telescoping blade holder extends to reach deep internal holes. Supplied with one #10 and one #20 deburring blade. P/N 12-00700\$12.20

Item	Description and Application	P/N	Price
#10 Deburring Blade	High-speed steel. For steel, aluminum & smaller holes	12-00800	\$2.15
#20 Deburring Blade	High-speed steel. For brass, Bronze, cast iron, larger holes.	12-00900	\$2.15
#40 Scraper Blade	High-speed steel. Small triangular blade.	12-01000	\$7.00
#42 Scraper Blade	High-speed steel. Large triangular blade.	12-01100	\$11.60
#48 Scraper Blade Holder	Holder has 10-32 threads. Accepts #40 & #42 blades. Extends to 3-1/2".	12-01200	\$7.85
#50 Scriber	Carbide-tipped scriber.	12-01300	\$7.90
#60 Deburring Blade	For backside deburring & for restricted positions	12-01400	\$3.20
#70 Deburring Blade	Carbide-tipped blade for deburring edges of sheet metal.	12-01500	\$6.60



SPEEDY BURR

Speedy Burr is designed to take the fatigue out of deburring. The wrist support makes the job easier. This tool is great for deburring spars and extrusions. The light weight, aluminum, hand-grip formed frame is comfortable and helps to maintain continuity in angle and depth of deburr. The wrist support is rubber lined to prevent skin abrasion. P/N 12-00650\$22.95



SPEEDY BURR II

Speedy Burr II is designed for deburring outside corners, sheet metal, machined parts, extrusions, castings, and plastic parts. This lightweight easy grip tool has a durable plastic coating on the handle for comfort and a sure grip. The burring tip is made from hardened steel and is replaceable. Speedy Burr IIP/N 12-00651\$14.50
Replacement Burr TipP/N 12-00652\$10.95

BACK-TAP REVERSE RE-THREADER

Other than the obvious benefit of the Back-Tap being a self-guided tool, the 18mm tool is short and compact enough to allow the use of the tool on either the top to bottom bug holes on any flat engine in existence. Many times the cowling on flat engines gets very tight around the front cylinders, especially on the top side. The shortness of the backtap allows the user to chase the threads on the furthest forward front cylinder without taking off the nose bowl or the top cowl, provided you can get at least one hand in there. After having used a Back-Tap, you will see that there is not a more safe and sensible way to chase threads. There is virtually no way to damage anything if the tool is used properly. There is no safer way to chase thread in a blind hole than with Back-Tap. Also ideal for use on radial engines. 14mm.....P/N 12-00743\$48.50
18mm.....P/N 12-00744\$48.50

AT508K CANNON CONNECTOR PLIERS



The AT508K features serrated jaws for improved gripping and a slip joint for improved leverage. Ideal for all common cannon connector applications. P/N AT508K\$23.60



TEMPIL MARKERS

Marks easily on metal, ceramic, glass, plastic, wood and paper. Markings are fast drying, permanent, weatherproof. Won't rub off, run, fade, chip, peel or blister. The surface can be wet, dry, rough, smooth or oily. Efficient on any horizontal, vertical or inclined surface. Long-lasting 6" ball point tube with non-clogging paint.

BlackP/N 12-11901\$6.25 RedP/N 12-11907\$6.25
WhiteP/N 12-11908\$6.25 YellowP/N 12-11911\$6.25

CESSNA COWLING FASTENER DRIVER



Slotted type cowling fasteners are not easy to fit with generic common screwdrivers. To overcome this, driver has a broad hollow cut tip that accurately engages the drive slot. Additionally, a narrow, spring loaded, plastic sleeve simultaneously guides the tip by fitting around the outside diameter of the fastener head. P/N 12-17615\$17.40

CESSNA SEAT RAIL GAGE



Allows for quick limit checking of seat rail hole and wear dimensions. Gage elements are made from heat treated blue tempered steel. Each element is marked to correspond to the limits set forth in the relevant ad. The three gage elements are linked together on a universal spiral key ring. P/N 12-01056\$17.95

COMPASS FILLING AID



The compass filling aid is designed to be used for filling most standard aircraft compasses. The standpipe is simply attached to the compass with a supplied special rubber band. The compass is then filled and purged through the standpipe. When all air is removed, and the level in the standpipe is constant, the plug is then installed through the filled standpipe. Thus the need for submerging for proper filling is eliminated. P/N 12-17604\$17.65

PORTABLE STRUT / TIRE PUMP



This pump is constructed of aluminum and nylon. Its overall dimensions are 29.5" (750 mm) long, with a body of approximately 1" diameter and a "T" handle and base 8" (200 mm) long. It weighs 1.65 lb (.75 kg), has a nylon hose with 2000 P.S.I. burst pressure and a strut valve fitting on the end that doesn't depress the valve so that no pressure can escape from the strut. The pump is capable of pumping up to 650 P.S.I. without any compressed air required for the inlet, which is more than adequate for most light aircraft, e.g.: Piper Cherokee PA28-235 needs 450 P.S.I. for the main struts with the weight of the Aircraft on the strut. The pump can also be used as a tire pump as a backup. The main use for the strut pump is for the individual aircraft owner that operates from remote areas and don't have access to a compressor, however they are popular with maintenance organizations as well. The pump is small and light enough to fit in the luggage compartment and have with you all the time ready for that moment when your Oleo goes flat. P/N 12-16714\$257.95

STRUT PUMPS



HX STRUT PUMP - Similar in appearance to a bicycle tire pump but designed for high pressure output. Ideal for the individual aircraft owner who does not have a large air compressor or who operates out of remote areas without air service. Just hook up the output hose to the strut and the inlet hose to an air bottle or a car's spare tire. Pump the "HX" pump just like a bicycle tire pump until strut is the proper height. Disconnect and you're done! Compact, lightweight. 1000 psi P/N 12-16710\$357.95



15X STRUT PUMP - This strut pump is professionally built for hard shop use or the discriminating builder. This is not a light duty modified grease gun, but a from-the-ground-up design incorporating the very best in materials. This 15x1 ratio pump allows pump to be used with 100 psi input (max 150 psi) delivering 1500 PSI output (Max. 2250 psi). The slide action controller makes operating this pump a breeze. Just hook the hose fitting to the strut, move the slide valve back and forth a few strokes and the strut will soon be serviced. The pump is slightly over two feet long and has a 28" high pressure air hose. Wt. 7 lbs. Built for many years of tough service. This pump can be modified & used with nitrogen. Instructions included. P/N 12-16700\$433.95

TO

TOOLS



QUICKCLICK: AN FITTING WRENCHES

This is a unique wrench for the serious engine builder, professional racer, and hobbyist who know the importance of protecting the finish of, and not over-tightening AN fittings. Unlike other AN wrenches, these are detachable from the handles and can be positioned in 3 locations to provide a straight or angled wrench! Easily detached, they incorporate a ball and detent, similar to socket wrenches. Made from T6061 aluminum, they will not scratch the surface of your AN fittings. Each kit contains one small and one large handle and one each, #3,4,6,8,10,12, & 16 wrench ends.

P/N 12-01054.....\$98.50

SMART TOOL DIGITAL INCLINOMETER



Smart Tool is a unique digital inclinometer with up to 0.1° of repeatable accuracy. Place Smart Tool anywhere and it provides an accurate digital readout of angular reading instantly with no interpretation or guesswork needed. It measures and displays any angle through 360°, and readings can be relative to any angle. Smart level even calculates complicated slope measurements in either percent or inches per foot. It is sunlight viewable, features 3 sensitivity settings, and has 120-hour battery life with auto shut-off. Smart Tool is ideal for fixture work, tube bending, metal forming, body work, drive shaft angles, camber, caster, and A-arm angles, and a wide variety of other applications in the aircraft and race car building industries. Also ideal for coordinating and aligning flight control surfaces. Compact & rugged, Smart Tool is powered by any 9V battery.

Smart Tool in 24" railP/N 12-21365\$118.95
Smart Tool in 48" railP/N 12-21370\$124.95



INSTANT ANGLE FINDERS

MODEL 300 (4" Dia. Dial) - With base and side V-grooved for easier use on round surfaces. Body of high impact ABS plastic. Dial protected by clear acrylic cover. Angle and grade chart on back shows angles in degrees & rise in centimeters per meter. P/N 12-00039.....\$8.90

MODEL 200M (2-3/4" Dia. Dial) - Very versatile tool —ideal plumb bob. Magnetic base and center hang hole. Body of high impact ABS plastic. Dial protected by acrylic cover. Angle and rise chart on back. P/N 12-14800.....\$9.75

PRO 360 DIGITAL PROTRACTOR



The Pro 360 Digital Protractor is a revolutionary measuring tool that provides an immediate, digital reading of all angles in a 360° circle. The machined aluminum frame is a rigid, light weight, ultra-precise platform that allows the state-of-the-art sensor and its microprocessor circuit to provide unsurpassed accuracy throughout the Protractor's 360° range. Typical used by aircraft builders, maintenance personnel and airport operators. P/N 12-20125.....\$224.95

MINI-AIR POWERED VACUUM



This handy air powered vacuum works off of an air compressor and is simple to use. The body of the unit is plastic or cast aluminum construction with an 18" clear plastic flex tube that can easily get into tiny spaces to clean. The canvas bag is easily removed for cleaning. Excellent for cleaning under instrument panel, behind pedals, picking up hardware & small tool accessories from tight spots. Wt. 8.5 oz.

Mini-Air Vacuum - plasticP/N 12-16820\$20.80
Mini-Air Vacuum - aluminum ..P/N 12-16821\$45.90
Spare Bag and ClipP/N 12-16825\$6.40
36" Clear Flex Hose.....P/N 12-16830\$9.80

FLEXLITE BORESCOPE INSPECTION KIT



This Borescope is designed to provide accurate inspection of the interior of an aircraft engine cylinder at a price affordable to everyone. The entire engine interior can be viewed by interchanging the three scan tubes. Built-in focusing range, for close inspection provides up to 6X magnification. Also included are a rigid 6" cable extender and illuminated swivel mirror that fits over the focusing head sleeve, providing viewing in inaccessible areas. Illumination is provided with a 3-cell battery light giving a powerful single beam of light (or focuses to broad range). P/N 12-18205.....\$325.00

Kit Contains: • Borescope w/Straight-thru Scan Tube • 6X Magnifier • 45° Scan Tube • Focusing Head • 60° Scan Tube • 6" Rigid Extension • 3 Cell Flashlight • Carrying Case • Illuminated Mirror • Wt: 3 lbs.

HAWKEYE PRECISION FLEXIBLE BORESCOPIES



Hawkeye precision borescopes feature the patented endoGRINS lens system for superior optical quality. The eyepiece can focus on an object from 0.280" (7mm) all the way to infinity at a maximum magnification of 120X. Kit includes the borescope, a high intensity Mag-Light flashlight, a SideWays™ 90° mirror for view-

ing at right angles, and a cleaning kit.
7" Hawkeye Hardy KitP/N 12-00337\$898.00
12" Hawkeye Hardy KitP/N 12-00338\$865.00

Note: ALL BORESCOPIES ARE NON-RETURNABLE

PROVISION 100/300 FIBEROPTIC SCOPE

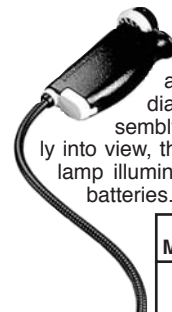

A breakthrough in fiberoptic technology has created the ultimate hand tool for engine and airframe diagnosis. The flexible cable is 18" or 36" long and fits easily into openings as small as 0.5" in diameter, allowing you to look inside without disassembly. The adjustable focus brings small objects clearly into view, the cable bends in any direction, and the powerful lamp illuminates dark areas. Operates on 2 AA replaceable batteries. An excellent tool for mechanics.

Model	Cable		Field of view	Part No.	Price ea.
	Length	Dia.			
100	18"	0.4"	40°	12-15310	\$198.95
300	36"	0.4"	40°	12-00221	\$242.95

The 10.6mm scopes have memory. The 5.8mm scopes are smaller with more light & heavier density, but do not have memory.

PV-100, 18" - 10.6 mm.....P/N 12-15310\$198.95
PV-300, 36"-10.6 mm.....P/N 12-00221\$242.95
PV-618, 18" -5.8 mmP/N 12-00289\$194.95
PV-636, 36"-5.8 mmP/N 12-00290\$238.95
PV-480, 48"-10.6 mm.....P/N 12-00344\$357.95
PV-720, 72"-10.6 mm.....P/N 12-00345\$437.95
PV-960, 96"-10.6 mm.....P/N 12-00346\$582.00

ACCESSORIES

PL-1000 Halogen bulbP/N 12-00291\$11.95
PM-1 Magnet AttachmentP/N 12-00292\$16.45
PVW-45 45° Mirror -10.6mmP/N 12-00293\$15.95
PVK-45 Mirror/Halogen Lamp Kit 10.6mmP/N 12-00294\$23.90
PVW-45M 45° Mirror 5.8P/N 12-00296\$15.95
PVK-45M Mirror/Halogen Lamp KitP/N 12-00297\$23.95

WORK LIGHTS - INSPECTION MIRRORS



CONDUCT-A LITE INSPECTION KIT

Kit consists of aluminum 2-cell holder, 1-cell holder for use in small areas, 6" straight Lucite conductor, 4" curved Lucite conductor for lighting around corners, 2-1/2" straight conductor for pin-point lighting, and clip on mirror which attaches to any of the Lucite conductors. When used with curved conductor it can virtually make light available around a corner in a full 360° arc. Operates on penlight batteries (not included). P/N 12-14900.....**\$19.50**

FLUORESCENT WORK LITE

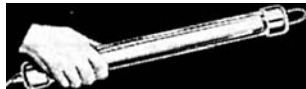

Lights a greater area than a 150 W bulb for 1/10 the electricity. Throws a glare-free light. Hold it or hang it. Cool, insulated, shatter-resistant. Does not get hot - safe to handle. For 110V AC. Furnished with 25-ft. yellow oil-resistant cord. P/N FL-15.....**\$39.95**



FLEXIBLE MICROLIGHTS

This Super-Bright Micro 360 Flexible LED Light is 10 times brighter than standard flashlights and lasts up to 100 hours on a single set of batteries! Features: •Stainless Steel • Lifetime Warranty • Focused lens power beam • Shock proof, water resistant and cold burning • LED-"Light-Emitting Diode" • White beam • 100 hours of light without a battery change •Diode-charge system • Easy on/off-switch • 6" in length • Batteries included. Micro FlexP/N 13-02846.....**\$24.95**



PILOT'S FLEX-LITE

This ingenious light puts a shadowless light beam wherever you want it. Stainless steel clip, visor, interior panel, shirt pocket, etc. and leaves your hands free. Flexible neck bends into nearly any position and stays there. Anodized aluminum construction with vinyl covered flexible cable. Body of light measures 5.5" with a 6" cable. Uses two AA batteries (not included). This light is the only light available with a precision ground optic lens for even light distribution. Available in a clear or red lensed model. ClearP/N 12-00383.....**\$21.95**



HEADLIGHTS

The Brighteyes Pro Headlights is a hands-free flashlight worn like eyeglasses to provide light for reading maps, instruments, repair work, and more. Excellent for work on aircraft, automotive applications, around the house, camping, & fishing. Headlights can be used with or without eyeglasses, and the lights will swivel to direct the light where you need it. (4) AAA batteries included. P/N 12-00242.....**\$12.95**



BEND-A-LIGHT

Bend-A-Light flexible brass-alloy high intensity light tools bend to any configuration and illuminate hard-to-reach areas where conventional lighting cannot go. The incredibly brilliant light beam penetrates anywhere! Bend-A-Light is a must for electronics, automotive, maintenance, repairs, locksmiths, industrial, hobbies, around the house and more. You bend it...and it holds! Bend-A-Light is the only complete line of professional quality high intensity flexible light tools. Available in 3 lengths and 3 different lamps to choose from. All Bend-A-Light models are made in USA and come with batteries installed.

Part No.	Description	Length Flex Shaft	Length Overall	Batt.	Candle-Power	Price
12-15005	Mini Pro	5"	11"	2-AAA	5,000	\$17.50
12-15150	Pro	10"	24"	2-AA	5,000	\$28.85
12-10250	Removable Shaft	16"	23"	2-AA		\$16.25
12-15020	Replacement Lamp					\$6.85
12-12110	Krypton Lamp					\$12.75

INSPECTION MIRRORS AND MAGNIFYING MIRRORS FOR ALL-ANGLE VIEWING

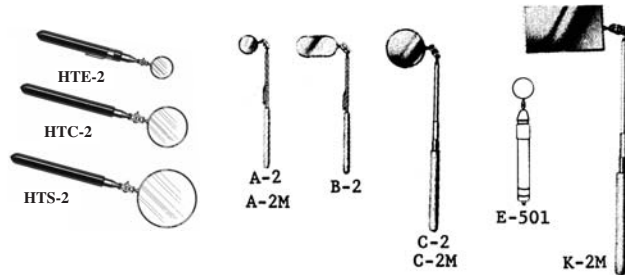

Double ball-joints of tempered spring steel move freely, hold desired position for viewing to 360°. Mirrors have brushed stainless steel backs and insulating vinyl grips. Refill mirrors available.

A-2 Circular Pocket Mirror - 7/8" Dia., Length 7.5" P/N A-2**\$4.50**

A-2M Circular Magnifying Pocket Mirror - 7/8" Dia., Length 7.5" P/N A-2M**\$6.50**

B-2 Oval Pocket Mirror- 1"x 2", Length 8.5" P/N B-2**\$5.20**

C-2 Circular Telescoping Mirror - 2.25" Dia. Length 10". Extends to 14". P/N C-2**\$7.10**

C-2M Circular Magnifying Telescoping Mirror - 2.25" Dia.; Length 10". Extends to 14" P/N C-2M**\$10.20**

K-2M Rectangular Magnifying Telescoping Mirror - 2-1/8" x .5"; Length 11.25"; Extends to 14.25". P/N K-2M**\$12.20**

E-501 Penlight Inspection Mirror - Circular mirror 1.25" dia. attachment, mounted on pocket penlight. P/N E-501**\$9.80**

HTE-2 - with 1.25" mirror for viewing in tight areas telescopes from 6.5" to 35" P/N HTE-2**\$9.40**

HTC-2 - w/ 2.25" mirror for viewing in less restricted areas telescopes from 6-1/2" to 36-3/8". P/N HTC-2**\$9.80**

HTS-2 - with 3.25" mirror for brightest clearest viewing with room to maneuver telescopes from 6-1/2" to 36-3/8". P/N HTS-2**\$11.30**



THE INSPECTOR

ADJUSTABLE LIGHTED INSPECTION MIRROR

No more trying to aim a flashlight at the old style mirror. Inspector is a one-hand tool that comes with a very bright light that illuminates the total inspection area. Easy to adjust the mirror angle. Once inserted into the inspection area, simply push or pull the thumb knob for a 90° mirror angle adjustment. The product is constructed of non-conductive materials for safety. The mirror, lamp, and 2-AA batteries (included) are easily replaceable.

InspectorP/N 12-15105**\$18.95**

Inspector Replacement Lamp ..P/N 12-15110**\$2.95**

Inspector Replacement Mirror..P/N 12-15115**\$1.75**



BINOCULAR MAGNIFIERS

Ground and polished optical lenses. Padded vinyl head band. Tilt-up lens frame. May be worn with glasses. For assemblers, inspectors and other craftsmen working with small or subminiature parts who need freedom of hands and elimination of eye strain and fatigue. All lenses interchangeable.

Part No.	Power	Focal Length	Price
950-3	1.75X	14"	\$23.40
950-5	2.25X	10"	\$23.85
950-7	2.75X	7"	\$24.60



MONOLOUPE LENS - For attachment to either side of lens plate for added power to existing lens.

P/N AL-950**\$5.95**

TO

TOOLS

AN WRENCHES



Designed and engineered to offer the highest performance & superior time saving benefits. There are 3 different size variations per handle that rotate and lock into 6 different positions. The head is constructed of high quality steel to prevent the jaws from flexing. Handle is constructed of 6061-T6 aluminum that is aircraft quality for durability and strength. The latest in technology, the AN wrench is absolute precision-in-the-palm-of-your-hand.

AN Wrench	Size	Part No.	Price
Large Handle	-16,-12,-10	12-00246	\$55.00
Small Handle	-8,-6,-4	12-00247	\$50.00
Set of 2	(1 ea. size)	12-00248	\$105.00
Large Handle	-20,-16,-12	12-00249	\$73.95
Medium Handle	-10,-8,-6	12-00250	\$72.95
Small Handle	-6,-4,-3	12-00251	\$71.95
Set of 3	(1 ea. size)	12-00252	\$218.85

SMART TOOL DIGITAL INCLINOMETER



Smart Tool is a unique digital inclinometer with up to 0.1° of repeatable accuracy. Place Smart Tool anywhere and it provides an accurate digital readout of angular reading instantly with no interpretation or guesswork needed. It measures and displays any angle through 360°, and readings can be relative to any angle. Smart level even calculates complicated slope measurements in either percent or inches per foot. It is sunlight viewable, features 3 sensitivity settings, and has 120-hour battery life with auto shut-off. Smart Tool is ideal for fixture work, tube bending, metal forming, body work, drive shaft angles, camber, caster, and A-arm angles, and a wide variety of other applications in the aircraft and race car building industries. Also ideal for coordinating and aligning flight control surfaces. Compact & rugged, Smart Tool is powered by any 9V battery.

Smart Tool in 24" railP/N 12-21365**\$118.95**
 Smart Tool in 48" railP/N 12-21370**\$124.95**

INSTANT ANGLE FINDERS



MODEL 300 (4" Dia. Dial) - With base and side V-grooved for easier use on round surfaces. Body of high impact ABS plastic. Dial protected by clear acrylic cover. Angle and grade chart on back shows angles in degrees & rise in centimeters per meter. P/N 12-00039**\$8.90**

MODEL 200M (2-3/4" Dia. Dial) - Very versatile tool — ideal plumb bob. Magnetic base and center hang hole. Body of high impact ABS plastic. Dial protected by acrylic cover. Angle and rise chart on back. P/N 12-14800**\$9.75**

PRO 360 DIGITAL PROTRACTOR



The Pro 360 Digital Protractor is a revolutionary measuring tool that provides an immediate, digital reading of all angles in a 360° circle. The machined aluminum frame is a rigid, light weight, ultra-precise platform that allows the state-of-the-art sensor and its microprocessor circuit to provide unsurpassed accuracy throughout the Protractor's 360° range. Typical used by aircraft builders, maintenance personnel and airport operators. P/N 12-20125**\$224.95**

MINI-AIR POWERED VACUUM



This handy air powered vacuum works off of an air compressor and is simple to use. Just plug it into the air hose using the 1/4" adapter (included) & start cleaning. The body of the unit is plastic or cast aluminum construction with an 18" clear plastic flex tube that can easily get into tiny spaces to clean. The canvas bag is easily removed for cleaning. Excellent for cleaning under instrument panel, behind pedals, picking up hardware & small tool accessories from tight spots. Wt. 8.5 oz.

Mini-Air Vacuum - plasticP/N 12-16820**\$20.80**
 Mini-Air Vacuum - aluminum ..P/N 12-16821**\$45.90**
 Spare Bag and ClipP/N 12-16825**\$6.40**
 36" Clear Flex Hose.....P/N 12-16830**\$9.80**

FLEXLITE BORESCOPE INSPECTION KIT



This Borescope is designed to provide accurate inspection of the interior of an aircraft engine cylinder at a price affordable to everyone. The entire engine interior can be viewed by interchanging the three scan tubes. Built-in focusing range, for close inspection provides up to 6X magnification. Also included are a rigid 6" cable extender and illuminated swivel mirror that fits over the focusing head sleeve, providing viewing in inaccessible areas. Illumination is provided with a 3-cell battery light giving a powerful single beam of light (or focuses to broad range).

Kit Contains:
 • Borescope w/Straight-thru Scan Tube
 • 6X Magnifier
 • 60° Scan Tube
 • Carrying Case
 • 45° Scan Tube
 • 6" Rigid Extension
 • Illuminated Mirror
 • Focusing Head
 • 3 Cell Flashlight
 • Wt: 3 lbs.
 P/N 12-18205**\$325.00**

HAWKEYE PRECISION FLEXIBLE BORESCOPIES



Hawkeye precision borescopes feature the patented endoGRINS lens system for superior optical quality. The eyepiece can focus on an object from 0.280" (7mm) all the way to infinity at a maximum magnification of 120X. Kit includes the borescope, a high intensity Mag-Light flashlight, a SideWays™ 90° mirror for viewing at right angles, and a cleaning kit.

7" Hawkeye Hardy KitP/N 12-00337**\$898.00**
 12" Hawkeye Hardy KitP/N 12-00338**\$865.00**

Note: ALL BORESCOPIES ARE NON-RETURNABLE

PROVISION 100/300 FIBEROPTIC SCOPE

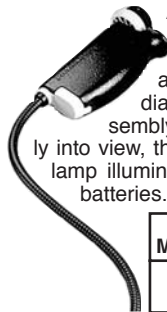

A breakthrough in fiberoptic technology has created the ultimate hand tool for engine and airframe diagnosis. The flexible cable is 18" or 36" long and fits easily into openings as small as 0.5" in diameter, allowing you to look inside without disassembly. The adjustable focus brings small objects clearly into view, the cable bends in any direction, and the powerful lamp illuminates dark areas. Operates on 2 AA replaceable batteries. An excellent tool for mechanics.

Model	Cable		Field of view	Part No.	Price ea.
	Length	Dia.			
100	18"	0.4"	40°	12-15310	\$198.95
300	36"	0.4"	40°	12-00221	\$242.95

The 10.6mm scopes have memory. The 5.8mm scopes are smaller with more light & heavier density, but do not have memory.

PV-100, 18" - 10.6 mm.....P/N 12-15310**\$198.95**
 PV-300, 36"-10.6 mm.....P/N 12-00221**\$242.95**
 PV-618, 18" -5.8 mmP/N 12-00289**\$194.95**
 PV-636, 36"-5.8 mmP/N 12-00290**\$238.95**
 PV-480, 48"-10.6 mm.....P/N 12-00344**\$357.95**
 PV-720, 72"-10.6 mm.....P/N 12-00345**\$437.95**
 PV-960, 96"-10.6 mm.....P/N 12-00346**\$582.00**

ACCESSORIES

PL-1000 Halogen bulbP/N 12-00291**\$11.95**
 PM-1 Magnet AttachmentP/N 12-00292**\$16.45**
 PVW-45 45° Mirror -10.6mmP/N 12-00293**\$15.95**
 PVK-45 Mirror/Halogen Lamp Kit 10.6mmP/N 12-00294**\$23.90**
 PVW-45M 45° Mirror 5.8P/N 12-00296**\$15.95**
 PVK-45M Mirror/Halogen Lamp KitP/N 12-00297**\$23.95**

DRAIN PANS - SHEARS - SPRAY SYSTEMS

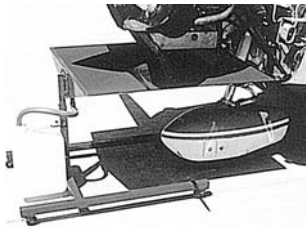

STANDARD FLUID DRIP PAN

Great for the private aircraft owner. It eliminates mess, saves time, and is environmentally friendly. All steel construction. Adjustable height. The model with trap features a hinged door for nose struts. Ships UPS direct from factory. Model DP-115 P/N 12-99110\$256.95



WING STAND

This wing stand is ideal for aircraft homebuilders or restorers needing to safely store and protect aircraft wings during the project. It accommodates virtually all shapes and sizes of wings and is available at a very economical price. We ship this wing stand direct to you from the factory (freight collect). Dims: 72"l x 44"h x 36"w. Assembly req. Each stand holds 2 wings. P/N 12-21390 ..\$159.00/ea



AEROROLLER-1000

AeroRoller makes movement of your aircraft or wheeled equipment easy. Aircraft can be loaded on AeroRoller without jack and minimum effort is required to move aircraft when on rollers. AeroRoller is constructed of Industrial 1/4" steel plate. Heavy duty Duraform 360° swivel castor wheels means no flat spots. Brake castor lock parking location. Each unit can carry 1000 lbs. Manufacturer's warranty covers defective parts & labor. 2-Roller SetP/N 13-00071\$124.95 3-Roller SetP/N 13-00072\$181.95

TENNSMITH BRAKES & SHEARS



Hand Brake & Stand - A versatile, economical hand brake which is designed for straight forming of mild steel in thicknesses of 22 gauge and lighter. Made in the U.S.A by Tennsmith. Bends material up to 48" wide. Wts: brake: 280 lbs. Optional stand: 95 lbs. Ideal for bending materials used in light aircraft construction. Shipped direct to you from factory in Tennessee.

Model S48-22 hand brakeP/N 12-20700\$557.00
Optional StandP/N 12-20705\$177.95



Universal Hand Brake & Stand - Tennsmith's heavy duty universal hand brake is a great tool for a wide range of sheet metal binding and forming operations in 12 gauge and lighter mild steel. The brake is ideal for both box and pan and straight bending in hold and cold rolled plate, stainless steel, aluminum, and heavy plastic. Welded steel plate construction for strength and rigidity. Bends material up to 48" wide Wts: brake: 1330 lbs. Optional stand: 95 lbs. Shipped truck collect direct to you from factory in Tennessee.

Model HBU48-12 Hand BrakeP/N 12-20710\$2,998.00
Optional StandP/N 12-20705\$177.95

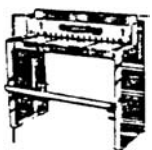

Foot Squaring Shear - Tennsmith squaring shears offer precision shearing and rugged construction. These shears feature traction, ground alloy tool steel blades to prevent material movement during shearing. Will shear material up to 16 gauge mild steel and up to 20 gauge stainless steel. Both blades are adjustable and back gauge gives highly accurate readings. Wts: Model 36: 700 lbs. Model 53: 950 lbs. Shipped truck collect to you direct from factory in Tennessee.

Model 36 Shear (Max. Cutting Width 37") P/N 12-20715\$1,771.00
Model 52 (Max. Cutting Width 52")P/N 12-20720\$2,185.00

Tennsmith -These products are shipped truck, priced F.O.B. McMinnville, TN. Allow 4-6 weeks for delivery



CITATION 240 PAINT SPRAYER/RESPIRATOR SYSTEM

The Citation HVLP 'twin turbine' system provides both a 'professional quality' paint spray system and the HobbyAir supplied-air respirator in one portable package. This system comes complete with everything you will need to spray exceptionally fine finishes with practically any material and to breathe in safety and comfort while you work. The basic system includes two 40' airlines (one for breathing and one for painting) and a half face mask. Available options include: A larger two-person Citation system with 3 airlines (two for breathing and one for spraying), Full face masks, and air-supplied hoods. This system comes with an unconditional 1-year warranty.

P/N 12-15900\$929.00

Optional 4 ft. whip hoseP/N 12-15910\$19.75



CITATION INTAKE ADAPTER

The Intake Adapter allows the pump unit to be placed inside the shop area, keeping it out of the elements. With the adapter installed, the vent hose can be extended to a fresh air location up to 50 feet away, allowing the pump to draw in fresh air from a distant location. The caution is to place the pump in a location inside the shop that is at least 30 feet away from the actual spray area in which it will not come in contact with flammable material. For example, the pump should never be placed inside a paint booth. Adapter kit comes complete with the steel adapter itself, screws, weatherstrip, hose clamp, 50 feet of 4-inch hose and installation instructions.

P/N 12-15901\$75.25



PRIMER PISTOL

Simple and cost effective way to apply small amounts of primer paint and liquid with minimal cleanup time. A valuable tool for aircraft builders. Requires empty film containers and 1/8" ID plastic tubing.

P/N 12-00686\$19.85



SUNEX SX-10 TOUCH-UP GUN

Ideal for tight areas. Holds approximately one pint of paint.

P/N SX-10\$45.70



SUNEX SX-70 SPRAY GUN AND CUP

Standard size. Holds one quart of paint.

P/N SX-70\$59.75

AXIS HVLP PAINT SPRAYERS

The Axis series of paint sprayers is designed to take the guesswork out of choosing a spraying system which can be confusing for the homebuilder who is going to paint for the first time. Rather than offer a wide variety of sprayers, Axis has selected the best turbine for each type of product normally used to finish an airplane. This is the SP 2003 (three stage turbine) which is furnished with 30 feet of air delivery hose and the Lexair spray gun. Select one of the three systems shown below based on type of material you will be spraying. If waterborne materials are going to be used, we can furnish systems for this process on a special order basis.

Sys. 1 to paint aircraft covered in fabric P/N 12-15920\$770.00

Sys. 2, to paint composite structure.....P/N 12-15930\$770.00

Sys. 3, to paint over metal or woodP/N 12-15940\$770.00

TO

SPRAY EQUIPMENT



SPRAY EQUIPMENT

MODEL 2001 AIR SPRAY GUN - This new gun incorporates the best features found in most heavy-duty production guns. The new grip will reduce operator fatigue and improve control. It utilizes the new style fluid nozzle with six air passages. It weighs only 24 oz. and is perfectly balanced. The head is forged brass and the body is anodized forged aluminum alloy. Spray pattern is adjustable from round to fan with a full range of intermediate settings. Air Flow: 8.1 CFM @ 50 PSI with No. 66 fluid nozzle and No. 66SA air nozzle.

Air connections - Fluid inlet - 3/8" NPS (m), Air inlet 1/4" NPS (m). All parts replaceable. Made in U.S.A. Furnished with Model 81-350 DRIP-PROOF 1 Qt. attachable siphon cup. Wt. 3.25 lbs.

- Model 2001 Gun and CupP/N 12-04000**\$267.55**
- Gun OnlyP/N 12-04100**\$222.95**
- Cup OnlyP/N 81-350**\$44.60**

BINKS CHANGE-OVER KIT

The standard Model 2001 gun is furnished with No. 66 fluid nozzle and No. 66SA air nozzle for general purpose spraying of materials such as lacquers, enamels, synthetics and acrylics. For spraying dope and other heavy bodied materials, a "Change-Over" kit is required. The kit includes a No. 67A fluid nozzle, a No. 67SA air nozzle and a No. 567 replacement needle. A 1-1/2 to 3 HP air compressor with 10.2 CFM air flow at 50 PSI recommended for best results. Wide selection of nozzle combinations available.

- Change-Over Kit.....P/N 12-04300 **\$102.95**

BINKS AIR HOSE

5/16" Dia. hose with standard 1/4" NPS connection at both ends.

- 5/16" Dia. x 25' LongP/N 71-1205**\$37.90**
- 5/16" Dia. x 50' LongP/N 71-1206**\$58.50**

A 5/16" diameter hose is recommended for efficient operation.



STAINLESS STEEL PRESSURE ASSISTED 1 QUART CUP

Bink stainless steel pressure assisted 1 quart cup & attachment.

- 80-500 cup/lid assembly P/N 12-01332**\$157.50**
- 82-367 cup gasket (poly) P/N 82-367**\$6.50**

BINKS MACH 1 HVLP



The Binks Mach 1 HVLP is a siphon-fed refinishing system that performs like your favorite conventional outfit but produces far superior transfer efficiency. A unique arrangement of air nozzle, fluid nozzle, and needle enable the Mach 1 to draw material from a standard siphon feed cup and avoid the need for a pressure cup. Eliminates the need for the operator to set fluid pressures. Delivers lower emissions for compliance with environmental regulations.

P/N	Description	Price
12-04410	MACH 1 Siphon Gun Only	\$496.25
98-1176	MACH 1 HVLP Siphon outfit -Spray Gun, 81-375 'No-Drip' Siphon Cup, &83-469 gun brush.	\$418.95
54-4080	Deluxe Siphon Nozzle Retrofit Kit incl. 45-9404 fluid nozzle (94S), 45-9704 fluid nozzle (97S), 46-9502 air cap (95AS), 46-9702 air cap (97AS), 54-4026 needle ass'y. (94F), 54-4029 needle ass'y. (97F), 54-3928 plug, 54-3925 washer, and 20-5170 nylon tie strap.	\$269.80
54-4081	Siphon Nozzle Retrofit Kit w/ 45-9704 fluid nozzle (97S), 46-9502 air cap (95AS), 54-4029 needle assembly (97F), 54-3928 plug, 54-3925 washer, and 20-5170 nylon tie strap in a reusable plastic display box.	\$132.77



BINKS SG-2 2 QUART PRESSURE CUP

Binks Steadi-Grip "SG-2" Pressure Cup is ideal for aircraft and for automotive refinishing, component and spraying and industrial applications where small batch production spraying is required. The 2qt. capacity is sufficient to complete large spray jobs without refilling the cup. It's lightweight and rugged construction is excellent for portability allowing the operator to make fluid and air control adjustments quickly and efficiently at the spray station. The internal construction is designed for waterborne and solvent base materials. Model 80-351 with Agit Cup is ideal for metallic and other paints required constant agitation. StandardP/N 80-350.....**\$285.95**
With AgitatorP/N 80-351.....**\$448.95**

HVLP SPRAY GUN OUTFITS

- P/N 98-1198 Includes 80-350 cup, fluid and air hose,**\$698.00** atomizing air valve, Mach 1 spray gun

MODEL 95 SPRAY GUN OUTFITS

- P/N 98-1197 Includes 80-351 cup, fluid and air hose,**\$672.00** atomizing air valve, Model 95 spray gun

MODEL 2001 SPRAY GUN OUTFITS

- P/N 98-1227 Includes 80-350 cup, fluid and air hose,**\$462.00** atomizing air valve, Model 2001 spray gun
- P/N 98-1228 Includes 80-351 cup, fluid and air hose,**\$682.00** atomizing air valve, Model 2001 spray gun

BINKS MODEL 95 SIGNATURE SERIES SPRAY GUN



Model 95 spray gun employs the best features of Binks' most popular conventional air spray guns. This gun delivers higher quality finish, faster production, less operator fatigue, greater fluid compatibility, and more application versatility than any spray gun currently available. Model 95 is a high production gun with stainless steel fluid passages which may be used with most coatings. This new gun replaces Models 18, 62, and BBR spray guns, incorporating the best features of all 3: drop-forged anodized aluminum body, stainless steel fluid passages, adjustable floating needle valve, hardened steel or stainless steel fluid nozzle, plated drop-forged bronze self-centering air nozzle, brass air valve cartridge, adjustable spray pattern, 3/8" NPS (m) fluid inlet, 1/4" NPS (m) air inlet. Weight 1 lb., 11 oz.

- Model 95 Hand GunP/N 12-14150**\$256.95**
- Model 95 gravity feed hand gun with 1-1/3" alum. pint cup P/N 12-04155**\$313.95**

WREN AIR BRUSH SET

Model No. 59-10005 includes 1/4, 1/2 and 2-1/2 fl. oz. color bottle assemblies, and 6 ft. plastic air hose with connections, packed in a durable styrene case. The Wren Air Brush is a "must" for retouching, special effects spraying and small parts finishing. Ship Wt. 20 oz
P/N 59-10006**\$142.95**



ORDER ONLINE!

www.aircraftspruce.com

- 45,000 Parts!
- 24 Hour Access!
- Fast, Easy Navigation!

TO

LINCOLN TIG WELDERS

TIG WELDING

TIG Welding is becoming more and more popular with experimental aircraft builders, racing teams, and just about anyone who wants to weld 4130 Chrome Moly tubing. The price of TIG equipment is no longer prohibitive to even the hobbyist TIG welder.



SQUARE WAVE 175 PRO

Professional racing teams and TIG welders everywhere rave about the professional performance packed into the Square Wave TIG 175. It features the lowest amperage in its class – as low as 8 amps – vital to TIG welding thin materials. Comes ready to weld!
 P/N 12-00761 **\$1,714.00**
 Undercarriage P/N 12-00768 **\$185.95**



INVERTEC V160-T For TIG and Stick Welding

A full function DC TIG inverter with excellent arc control. Its built-in gas solenoid and choice of High Frequency or Touch-Start TIG™ starting make it ideal for a wide variety of DC TIG applications. The V160-T can also weld stick with a variety of popular Lincoln stick electrodes. Its portable rugged design and 115/230V 50/60Hz operation make it ideal for both in shop and field use. The V160-T comes with 10 ft. 115V Input Cord and NEMA 5-

15P plug; NEMA 5-20P 20 amp plug; torch adapter for 9 or 17 series torches; adjustable shoulder strap; and ground clamp with cable.
Features: • Advanced inverter technology for superior TIG performance • Auto-reconnect between 115/230V 50/60Hz input power • Line voltage compensation enables use on remote power from an engine drive generator. • Selectable Touch Start TIG starting or high frequency starting. • Thermal and voltage overload protection for long life of internal components • Built-in pulsing functions • Integral gas and power connector for simple torch connections and quick changes between TIG & stick welding • Lightweight, rugged package for ultimate portability and durability • 3 year warranty on parts and labor.

P/N 12-00386 **\$1,338.00**

V160-T & V205-T options

Welding Cart P/N 12-00777 **\$75.50**
 12-00451 Foot operated Amptrol P/N 12-00766 **\$248.95**



V205-T AC/DC INVERTEC For TIG and Stick Welding

Ideal for critical AC or DC TIG Welding applications. Variable AC frequency allows you to focus the arc when precise arc control is required. The 115/230V auto-reconnect makes the V205-T AC/DC truly flexible and the rugged, portable, lightweight design is ideal for shop or field environments. The unit comes with a 10 ft. 230V input cord and plug; a Twist-Mate Torch Adapter for 9 and 17 Series one piece torches; Twist-Mate adapter for work cable; and adjustable shoulder strap. This

full featured TIG Welder is also capable of Stick Welding. **Features:** • Advanced inverter technology optimizes arc performance in a lightweight package. Weighs only 33 lbs (15 kg). • AC or DC output for a wide variety of material types and thicknesses. • 3 modes of operation DC TIG, AC TIG or Stick. • Full-featured TIG controls. • Auto-reconnects for 115/230V 50/60Hz input power. • Line voltage compensation allows remote power from an engine driven generator. • Adjustable AC Frequency for critical welding applications. • Selectable AC waveshapes: square, sinusoidal, triangular. • 3 year warranty on parts and labor.

P/N 12-00384 **\$2,611.00**

One-Pak™ Package Includes: V205-T Foot Amptrol (K870) and TIG-Mate 17 Starter Kit. Assembly required. P/N 12-00776 **\$3,097.00**



PRECISION TIG 185

Consider the Precision TIG 185 for general fabrication, automotive/motorsports, vocational schools or the serious hobbyist. Professional features like patented Micro-Start Technology ensures a soft start throughout the amperage range. Patented Auto-Balance takes the guesswork out of optimizing cleaning action versus penetration. Standard Pulse control makes it easy to gain even greater heat control on thin materials. Compare the built-in torch parts storage compartment or torch cable/helmet hanger. And, get the optional cart and add a sizable storage bin for your remote and cables, twin filler rod tube stands and a low-lift gas bottle platform.

The Best Weld Performance: • 5-185 amps is the widest welding range in its class • Patented Micro-Start™ Technology delivers extremely stable low amperage starting and welding • Auto-Balance mode with manual adjustment provides the simplicity and flexibility to make great looking aluminum welds • Free! Built-in TIG pulser helps you make great welds • Great Stick Welder — Including Fleetweld® 5P (E6010).

Simple Controls & Ease of Use: • Digital Meters, and simple, well-spaced controls • Free GTAW (TIG) Handbook & TIG Slide Rule • Ready-Pak™ Models include a Pro-Torch PTA-17 air-cooled 150 amp torch with new Ultra-Flex cable. More Convenience & Value. **Features:** • Standard torch parts storage compartment and cable hanger keeps you organized • Add an optional understorage cart for extra storage and portability.

Superb Quality: • Fan-As-Needed™ (FAN) prevents thermal cycling • CSA C/US certified. • Lincoln 3 year Warranty on parts and labor.

Ready-Pak™ Package Includes: Precision TIG 185, 10 ft. Work Cable and Clamp, 9 ft. Input Power Cord with NEMA 6-50P Plug, NEMA 6-50R Receptacle, TIG Slide Rule, GTAW Handbook, PTA-17 Pro-Torch TIG Torch (12.5 ft.), Gas Regulator with Hose, & Foot Amptrol (K870). Shipped fully assembled. P/N 12-00761 **\$1,714.00**

Ready-Pak™ Package w/Cart: Includes K2347-1 plus Understorage cart. P/N 12-00762 **\$2,042.00**

Understorage Cart P/N 12-00764 **\$200.95**

Stick Electrode Holder and Cable with Twist-Mate Connector P/N 12-00765 **\$47.10**

Foot operated Amptrol P/N 12-00766 **\$248.95**

TIG-Mate 17 TIG Torch Starter Kit P/N 12-00767 **\$263.95**



PRECISION TIG 275

The Precision TIG 275 is the mainstay in the next generation of the Square Wave family of machines. Patent-pending Micro-Start™ Technology provides unrivaled and revolutionary arc performance ideal for critical AC or DC welding in fabrication, aerospace, production, motorsports, and vocational applications. Available in both machine-only models or in a convenient Ready-To-Weld Package, the Precision TIG 275 combines both outstanding value-added features, with precision arc performance to meet all of your welding needs. **Features:** • Ready-To-Weld package with under-cooler cart water cooler and storage drawer for helmet, gloves, foot pedal, and work cable/clamp • Patent pending Micro-Start technology for state-of-the-art low amperage starting: 2 amps DC, 5 amps AC • Smooth, controllable focused arc for precision TIG welding performance • Neat/organized cable management with integrated torch holster • Water-cooled torch connections with no adapters side mounted to keep out of the way and protected • Built-in storage compartment with removable tray for torch consumables • Built-in holders for filler rod tubes • Simple, easy to use controls • Energy-efficient design • Stick capable with E6010 and E7018 electrodes • Optional Advanced Control Panel integrates TIG pulsing and trigger controls into the machine • Reliable under-cooler cart water cooler featuring industry recognized ProCon® pump tucked neat and tidy underneath machine for neat set-up • Optional power factor correction capacitors save on electricity cost when welding at higher currents • Separate output studs for work cable/clamp and electrode holder allows you to quickly change between stick and TIG welding processes • Easily accessible reconnect panel for convenient installation • CSA NRTL/C approved • Removable access door for easy spark gap maintenance • Reliable, positive locating polarity switch • Minimum output control allows you to preset minimum amperage. Aids starting when using large tungstens. Also allows operator to control foot pedal resolution between minimum and maximum amperage • Fan-as-Needed™ (F.A.N.) minimizes thermal cycling of internal machine components, minimizes internal contamination when not welding, and saves on electricity costs • Automatically switched auxiliary power receptacle runs water cooler only as needed • 3 year warranty on parts and labor.

P/N 12-00390 **\$673.00**

TO

AIRCRAFT SPRUCE WEST
CORONA, CA • (877) 4-SPRUCE

584
Prices Subject to Change Without Notice

AIRCRAFT SPRUCE EAST
PEACHTREE CITY, GA • (877) 477-7823

WELDING EQUIPMENT



TIG TORCH OUTFITS

125 amps, light duty, air cooled torch outfit with flex head, Superflex cable, and 35M dins gas through connector. P/N 12-00391**\$184.00**

210 amps, heavy duty, air cooled torch outfit with Superflex cable and 35M dins gas through connector. P/N 12-00392**\$198.00**

TIG TORCH ACCESSORY KITS

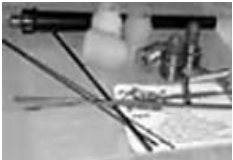

Did you know a Gas Lens can save you as much as 40% on your Argon Gas costs? Gas Lens' use a series of fine screens which provide better diffusion of the gas stream with less turbulence as it leaves the nozzle of the TIG torch. Diffusion of the gas stream provides better gas coverage in the heat affected zone. Better coverage means you can safely reduce the amount of Argon being distributed through the TIG Torch. This results in a better weld while saving you money.

The 9GL-Kit comes with .040, 1/16, 3/32 Collets, Gas Lens Collet Bodies, Gas Lens Nozzles, (#5, #6, #7), a long Back Cap, and an assortment of 2% Thoriated and Ceriated Tungsten in a convenient plastic box. P/N 12-00393**\$49.31**

The TDA-17HGL-Kit comes with 1/16, 3/32, 1/8 Collets, Gas Lens Collet Bodies, Gas Lens Nozzles, long Back Cap, Large Insulator, and an assortment of 2% Thoriated and Ceriated Tungsten in a convenient plastic box. P/N 12-00394**\$79.95**

TORCH HEADS

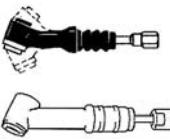

125 amp, flex head, air cooled torch head P/N 12-00395**\$63.25**

210 amp, air cooled torch head P/N 12-00396**\$51.50**



TORCH HANDLES

For 9 Torches P/N 12-00397**\$9.95**
For 17H Torches P/N 12-00398**\$11.00**

CABLES



You'll flip over how flexible this cable really is. So easy to work with.

12.5' Superflex Cable for 9 Torch Superflex 12 ..P/N 12-00399**\$62.50**

12.5' Superflex Cable for 17H Torch Superflex 12HP/N 12-00401**\$110.95**



TIG CALCULATOR

Just tell it what material you're welding, the thickness, and type of weld (butt, lap, etc.), and it will give you information concerning your weld such as travel speed, number of passes needed, tungsten type and size, what amperage to run, and speed of welding. Slide rule style. P/N 12-00444**\$8.80**

COLLETS



For 9 Torches

.020.....	P/N 12-00402	\$1.16
.040.....	P/N 12-00403	\$1.68
1/16.....	P/N 12-00404	\$1.79
3/32.....	P/N 12-00405	\$1.79

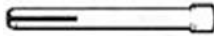

For 17H Torches

.020.....	P/N 12-00406	\$1.38
.040.....	P/N 12-00407	\$1.48
1/16.....	P/N 12-00408	\$2.15
3/32.....	P/N 12-00409	\$1.38
1/8.....	P/N 12-00410	\$1.38

COLLET BODIES



For 9 Torches

.020.....	P/N 12-00411	\$2.34
.040.....	P/N 12-00412	\$2.34
1/16.....	P/N 12-00413	\$2.60
3/32.....	P/N 12-00414	\$3.65

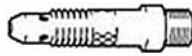

For 17H Torches

.020.....	P/N 12-00415	\$3.30
.040.....	P/N 12-00416	\$3.30
1/16.....	P/N 12-00417	\$3.40
3/32.....	P/N 12-00418	\$3.55
1/8.....	P/N 12-00419	\$3.55

ALUMINA NOZZLES



For 9 Torches

#4 (1/4")	P/N 12-00420	\$3.35
#5 (5/16")	P/N 12-00421	\$2.05
#6 (3/8")	P/N 12-00422	\$3.45
#7 (7/16")	P/N 12-00423	\$3.80
#8 (1/2")	P/N 12-00424	\$1.67
#10 (5/8")	P/N 12-00425	\$1.67

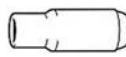

For 17H Torches

#4 (1/4")	P/N 12-00426	\$2.10
#5 (5/16")	P/N 12-00427	\$2.55
#6 (3/8")	P/N 12-00428	\$1.85
#7 (7/16")	P/N 12-00429	\$2.15
#8 (1/2")	P/N 12-00430	\$2.60
#10 (5/8")	P/N 12-00431	\$1.51
#12 (3/4")	P/N 12-00432	\$1.51

BACKCAPS



For 9 Torches

Short.....	P/N 12-00433	\$4.20
Medium.....	P/N 12-00434	\$3.25
Long.....	P/N 12-00435	\$4.80

For 17H Torches

Short.....	P/N 12-00436	\$3.20
Long.....	P/N 12-00437	\$3.85

TO

WELDING EQUIPMENT

WELDING HELMETS

- 
- Passive Helmet shade 10 black
P/N 12-00454\$46.70
 - Passive Helmet Checkered Flag decal shade 10
P/N 12-00455\$51.99
 - Auto-Darkening Helmet shade 10. 2x4 A-D black.
P/N 12-00456\$155.99
 - Auto-Darkening Helmet shade 10. 2x4 A-D Checkered flag helmet
P/N 12-00457\$208.95
 - Welding Goggles, soft frame, fixed front, shade 5
P/N 12-00458\$2.50

MAGNETS

- 
- Designed to hold any ferrous metal at 45, 90 and 135 degrees for welding, soldering, pipe installation, etc.
- SmallP/N 12-00459\$3.55
 - MediumP/N 12-00460\$4.55
 - LargeP/N 12-00461\$9.40
 - Extra LargeP/N 12-00462\$8.10

SPARK LIGHTERS

- 
- Single Flint Spark Lighter
P/N 12-00463\$2.20

TIP CLEANERS

- 
- Standard size, aluminum case
P/N 12-00464\$2.20

WIRE BRUSH

- 
- Stainless Steel, hard tied wire brush made of high quality wires and hard wood for handles
P/N 12-00465\$1.44

CYLINDER WRENCH

- 
- 3-1/8" long box wrench for B & MC cylinders; 3/16" box (actually .194), cadmium plated
P/N 12-00466\$0.54

HARRIS MODEL 15 CLASSIC TORCH HANDLE



The Model 15 is a lightweight, aircraft style featuring a forward valve designed to permit changing flame settings with one hand. For welding, heating and brazing with fuel gases. • Class A 3/8"-24 hose connection • Cap: Cuts 2", welds to 5/16" • UL listed • Length: 5-3/4", Wt: .5 lbs. Torch Handle P/N 12-00687\$139.50

- 
- B-15-3 MixerP/N 12-00688\$65.00

- 
- Welding Tip.....P/N 12-00689\$14.50

- Torch Handle Kit - Torch, Mixer and Tip**P/N 12-00690\$219.00

TIG TUNGSTEN

Sold in packages of 10

- 
- 2% Thoriated**
 - 1/16P/N 12-00438\$18.20
 - 3/32P/N 12-00439\$41.40
 - 2% Ceriated**
 - 1/16P/N 12-00440\$19.70
 - 3/32P/N 12-00441\$44.30
 - Pure**
 - 1/16P/N 12-00442\$18.60
 - 3/32P/N 12-00443\$39.65

TIG FILLER MATERIALS



36" Cut Lengths are packaged in 1 lb. tubes to provide you the flexibility of buying only what you need for your job.

Base Material	Use Filler	Size	Part No.	Price/Lb.
4130	ER80S-D2	.035	12-00473	\$16.40
4130	ER80S-D2	.045	12-00474	\$8.60
4130	ER80S-D2	.062	12-00475	\$8.20
4130	ER70S-2	.035	12-00477	\$10.50
4130	ER70S-2	.045	12-00478	\$9.60
4130	ER70S-2	.062	12-00479	\$7.60
Aluminum	ER4043	.045	12-00480	\$14.50
Aluminum	ER4043	.062	12-00481	\$12.90
Aluminum	ER5356	.045	12-00482	\$19.10
Aluminum	ER5356	.062	12-00483	\$13.00
Stainless Steel	ER312	.035	12-00484	\$28.20
Stainless Steel	ER312	.045	12-00485	\$31.30
Stainless Steel	ER312	.062	12-00486	\$15.80
Stainless Steel	ER308L	.035	12-00487	\$13.00
Stainless Steel	ER308L	.045	12-00488	\$22.30
Stainless Steel	ER308L	.062	12-00489	\$12.50
Inconel	NICKEL 625	.035	12-00490	\$54.25
Inconel	NICKEL 625	.045	12-00491	\$51.85
Super Alloys	ALLOY W	MKT	Special Order	Call
Titanium	TITANIUM	MKT	Special Order	Call
Magnesium	TITANIUM	MKT	Special Order	Call

MIG FILLER MATERIALS

Packaged in 2 lb. spools.

- ER80S-D2, size .030P/N 12-00467\$34.70
- ER70S-2, size .023P/N 12-00468\$39.50

GAS WELDING FILLER MATERIALS

- 36" cut lengths for gas welding 4130 with ER60-S2
.062 (RG60 - .062)P/N 12-00472\$6.70

BRAZING AND SILICON BRONZE

- Silicon Bronze -** .045P/N 12-00469\$11.94
- .062P/N 12-00470\$10.65

GAS WELDING / BRAZING

PORTABLE TORCH OUTFIT



Designed for a variety of professional jobs. Capable of cutting up to 1/2" steel, welding up to 1/8" steel and brazing up to 1" copper tubes.
P/N 12-00446\$410.00

SMALL OXY-ACETYLENE KIT

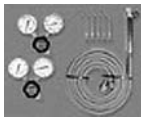

With regulators. Designed for hobby, crafts, plumbing, etc. Braze and solder material from the thinnest up to 1/8" thick steel, melt up to 3 oz. silver. Provides stable and precise concentrated feather flame up to 6000°F for various materials such as metals, ceramics, and glass.
P/N 12-00447\$306.00

CUTTING TORCH ATTACHMENT



Cuts up to 3". Spiral tube mixer design optimizes the mixture of fuel and oxygen. Stainless steel tubes and lever. "A" hose fitting, 3/8"-24 thread.
P/N 12-00448\$102.50

BOTTLES AND TOTE



Plastic Stand, Oxygen and Acetylene cylinders
Plastic Stand holds "MC" Acetylene cylinder and "R" Oxygen cylinder P/N 12-00449\$39.95
"MC" Acetylene Cylinder (empty)P/N 12-00451\$68.00
"R" Oxygen Cylinder (empty)P/N 12-00452\$76.00

TO

WELDING EQUIPMENT



AC-225C STICK WELDER

This stick welding power source has continuous output control and produces a very smooth welding arc at any amperage. The AC-225C can be used for many welding applications such as maintenance repairs, fabrication, modifying equipment, and creating or rebuilding tools, fixtures, or worn parts.

Features: • Easy Installation • Input power cable and plug included • Easy to Operate • Electrode holder and cable, work clamp and cable, sample electrodes, welding helmet and welder's guidebook all included • Easy to use controls • Convenient size to allow easy storage and handling • 3 year warranty including parts and labor • Output: 170 amps, 25 volts, 20% duty cycle • Amp Range: 40-225 • Size: 15.2" h X 14" w X 13.5" d • Weight: 86 lbs. • CSA approved • UL listed • Powder Paint Finish for increased durability.

P/N 12-00772\$272.95
Utility CartP/N 12-00773\$145.95

AC/DC 225/125 STICK WELDER



AC/DC 225/125 is the deluxe version of the AC-225. The same design but enhanced with the smoother, more stable DC welding arc. This model gives you the flexibility to use the AC arc for welding heavy plates or the DC for thinner materials giving you a low current, stable arc. The AC/DC 225/125 is perfect for use in the home, on the farm, shop, or for professional use.

Features: • Easy installation including input power cable and plug • Electrode holder and cable, work clamp and cable, sample electrodes, and welder's guidebook all included • Easy to operate • Easy to use front mounted polarity switch and full amperage selector switch for accurate procedure setting. • 3 year warranty including parts and labor • Output: AC: 225 amps, 25 volts, 20% duty cycle • DC: 125 amps, 25 volts, 20% duty cycle • Amperage range: AC 40-225, DC 30-125 • Size: 24" h X 17.3" w X 12" d • Wt: 129 lbs.

P/N 12-00774\$467.95
Wheel KitP/N 12-00775\$10.60

PRO-CUT 25 PLASMA CUTTER



The Pro-Cut 25 is one of the best examples of how portable and easy to use today's plasma cutters can be. It combines the next generation of plasma technology and enough power to easily cut 3/8" mild steel in a package that weighs only 29.5 lbs. (13.4 kg).

The power source automatically reconnects between 115V or 230V for easy set-up. This further extends the flexibility of this plasma unit. HVAC and autobody companies will find the Pro-Cut 25 especially easy to use with its back lit LED status lights, 15 ft. plasma torch, and integral air controls.

Features: • 25 amps of cutting power from only a 29-1/2 lb. package (without cables) for competitive performance on materials up to 3/8" thick • 60% duty cycle at maximum output assures generous high end capacity when connected to 230V • Patent pending PCT 20 torch with VORTECH™ technology consumables for unmatched cutting speed and precision • PCT 20 torch shares common internal components with the larger 80 Amp torch model for the ultimate in torch reliability • The longest consumable life in the industry • Standard air pressure regulator with gauge • Automatic re-connection between 115V and 230V for easy power connect and portability • Back-lit LED system for status indicators. Eliminates confusion yet conveys all the information necessary to monitor power source readiness • Unit comes ready to use with torch, work lead and spare consumables • Parts-in-Place safety indicator and lockout circuit to protect both the operator and the system • Thermostatically protected against overheating.

P/N 12-00783\$1,194.00
Utility CartP/N 12-00777\$75.50
PCT 20 hand torch (15")P/N 12-00784\$260.95



SP-135T WIRE FEEDER/WELDER

SP-135T is a lightweight, compact 120V wire feeder/welder and breezes through MIG welds on a wide range of materials including mild steel, stainless steel and aluminum. Handles flux-cored welds on mild steel with ease. Practically everything you need to MIG weld mild steel is right in the box. **Features:** • Ready to weld! Includes mild steel MIG wire and adjustable gas regulator and hose kit. Just add shielding gas (sold separately) • Large easy to set knobs provide 4-

position adjustable tap voltage control and continuous full-range control of wire feed speed • Capabilities include welding 24 gauge through 5/16" mild steel plate. Install K664-2 to weld 22 gauge through 12 gauge aluminum • Designed to feed .023 - .035" (0.6-0.9mm) diameter mild and stainless steel MIG wire, .035" (0.9mm) diameter flux-cored wire and .035" diameter 4043 aluminum MIG wire • Welder settings reference chart conveniently located inside wire feed section door makes it easy to set the machine for mild steel welding jobs • Gun trigger safety feature keeps welding wire electrically "cold" until trigger is pressed • Adjustable brake spindle accommodates both 8" (200mm) diameter and 4" (100mm) diameter spools of wire • Built-in "burnback" function insures proper wire stick-out after each weld with no sticking in the weld puddle. **Unit includes:** • 4-Step Tap voltage control • Magnum® 100L welding gun and 10ft. (3m) cable assembly, with gas nozzle, .023" - .035" (0.6-0.9mm) cable liner and .023/.025" (0.6mm) contact tip • 10ft. work cable & work clamp • 6 ft input power cord with NEMA Type 5-15P plug • Guide tubes and reversible drive roll for .023-.035" solid MIG wire and .035" Innershield® flux-cored wire • Factory installed gas solenoid valve • Adjustable gas regulator and hose for Argon and Argon-blend gases • 2 lb. spool of .025" SuperArc L-56 mild steel MIG wire • 6 spare .023/.025" contact tips • Welding handshield with #10 filter plate and clear glass cover plate. SP-135T P/N 12-00779\$499.95

SP-135T One-Pak Package - includes SP-135T welder an dK2275-1 Utility cart. Assembly required.P/N 12-00780\$568.00
Deluxe adjustable gas regulator & hose kitP/N 12-00781\$103.95
Welding Cart (80 cu. ft. bottle cap.)P/N 12-00777\$75.50
Utility Cart (150 cu. ft. bottle cap.)P/N 12-00773\$145.95

SP-135 PLUS WIRE FEEDER/WELDER



This user-friendly wire feeder/welder is ready to help you make short work of many around-the-home jobs, hobby projects, autobody repairs or farm chores! SP-135 Plus handles MIG welds on a wide range of materials including mild steel, stainless steel & aluminum. Flux-cored welds on mild steel are a breeze. Achieve outstanding performance on thin sheet metal to medium plate by fine-tuning the arc using the continuous output voltage and wirefeed speed controls. Also boasts industry leading output and arc performance in the 115V machine class. To top it off, we've made it easy to get started - virtually everything you need to MIG weld mild steel is included in one convenient package! Just add shielding gas (sold separately).

Features: • Ready to weld! Includes mild steel MIG wire an dadjustable gas regulator and hose kit. • Continuous full-range adjustment of voltage and wire feed speed allows for fine-tuning of the arc and precise control of heat input. • Capabilities include welding 24 gauge through 5/16" mild steel plate. Install K663-2 to weld 22 gauge through 1/8" aluminum • Designed to feed .023 - .035" (0.6-0.9mm) diameter mild and stainless steel MIG wire, .035" (0.9mm) diameter flux-cored wire and .035" dia. 4043 aluminum MIG wire • Welder settings reference chart conveniently located inside wire feed section door makes it easy to set the machine for mild steel welding jobs • Gun trigger safety feature keeps welding wire electrically "cold" until trigger is pressed • Adjustable brake spindle accommodates both 8" (200mm) dia. and 4" (100mm) dia. spools of wire • Built-in "burnback" function insures proper wire stick-out after each weld with no sticking in the weld puddle. **Unit incl.:** • Magnum® 100L welding gun & 10ft. (3m) cable assembly, with gas nozzle, .023" - .035" (0.6-0.9mm) cable liner and .023/.025" (0.6mm) contact tip • 10ft. work cable and work clamp • 6 ft input power cord with NEMA Type 5-15P plug • Guide tubes and reversible drive roll for .023-.035" solid MIG wire and .035" Innershield® flux-cored wire • Factory installed gas solenoid valve • Adjustable gas regulator and hose for Argon and Argon-blend gases • 2 lb. spool of .025" SuperArc L-56 mild steel MIG wire • .030" (0.8mm) contact tip. SP-135 PlusP/N 12-00445\$572.00

SP-135T One-Pak Package - includes SP-135 Plus welder & K2275-1 Utility cart. Assembly required.P/N 12-00782\$666.00
Deluxe adjustable gas regulator & hose kitP/N 12-00781\$103.95
Welding Cart (80 cu. ft. bottle cap.)P/N 12-00777\$75.50
Utility Cart (150 cu. ft. bottle cap.)P/N 12-00773\$145.95

TO

WELDING EQUIPMENT

VISION GUARDIAN WELDING HELMETS



WELDING HELMET - Features: • Conforms to ANSI Z87.1, CE EN169 & EN379 • Splatter Guard Replacement Filters: Part no. 383HSF • Weight: 1.4 lbs. • Solar powered to recharge batteries • Multiple light sensors • Panel size: 4.5"x 5.25"x .28" (114 x 136 x 7mm) • Viewing area: 2.4"x 3.8" (9.12 sq. in.) • Outer shade adjustment knob - Light state: Shade 4; Dark state: Shades 9, 10, 11, 12, 13 • External access battery drawer: 2pc 3V CR2032 lithium batt. (incl.)

P/N 12-01034 **\$206.50**

WELDING HELMET - Features: • Conforms to ANSI Z87.1, CE EN169 and EN379 • Splatter Guard Replacement Filters: Part no. 383KSF • Weight: 1.4 lbs. • Solar powered to recharge batteries • Multiple light sensors • Panel size: 3.5"x 4.3"x .275" (90x110mm) • Viewing area: 1.6"x 3.8" • Outer shade adjustment knob - Light state: Shade 4; Dark state: Shades 9, 10, 11, 12, 13 • External access battery drawer: 2pc 3V CR2032 lithium battery included.

P/N 12-01035 **\$135.60**



WELDING HELMET - Features: • Conforms to ANSI Z87.1 • Splatter Guard Replacement Filters: Part no. 383CSF • Weight: 1.6 lbs. • Multiple light sensors • Panel size: 2.125"x 4.25" (53x107mm) • Viewing area: 1"x 3.625" (25x92mm) • Shade adjustment (internal) - Light state: Shade 4; Dark state: Shades 10, 11, 12 • Internal access battery drawer: 2pc 3V CR2032 lithium batt. (incl.)

P/N 12-01036 **\$99.85**

HENROB 2000 IV WELDING TORCH



The revolutionary design of the Henrob 2000 Torch makes it the ideal welding torch for aircraft construction. The Henrob 2000 allows less oxidation, minimal flux, reduced pressures and substantial materials savings. Fewer tips are required and hose fatigue is lessened. Perfect for steel and aluminum welding and cutting. Highly recommended by many aircraft builders. Formerly known as the Dillon Mark III.

P/N 12-16000 **\$489.00**

Henrob Instructional Video P/N 12-05150 **\$16.95**

PORTASOL CORDLESS BUTANE SOLDERING TOOL KIT



The Portasol Soldering Tool Kit contains four different tools. Simple tip/accessory installation allows you to convert into a soldering iron, blow torch, hot blower or hot knife within seconds. Ideal for aircraft, automotive, marine and home use. The hot knife will quickly cut and seal repairs on dacron, mylar and nylon. The soldering iron is ideal for working on electronics and avionics. Portasol is lightweight and fits easily in a tool box. Features cordless, go-anywhere versatility, 90 minute continuous use capacity, refills in 20 seconds with standard butane lighter fuel, and full 2 year warranty. Kit includes Portasol soldering tool with 2.4 MM tip, hot knife, blow torch, hot blower, cleaning sponge, safety stand and rugged plastic storage case.

P/N 12-20600 **\$49.95**



SMITH WELDING OPTIONAL EQUIPMENT



TWO-STAGE REGULATORS - For the professional. Heavy duty, w/check valves.
H1421A-510 for Acetylene, 0-15 PSI
.....P/N H1621A-510 **\$158.95**



CUTTING TORCH - Fits ASI torch body with cutting capacity up to 3" steel.
Head Angle 90°P/N AC309 **\$119.95**

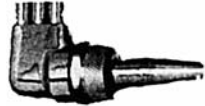

CUTTING TIP - Use in AC305 and AC309 assemblies. MC-12-0 (Cutting Range 3/16" - 3/8")
Smaller and larger tips available, from AW2000 for very light metal (to 1/32") to AW210 for 1/2".
P/N MC-12-0 **\$14.60**



HUNTSMAN FACE SHIELD - A very practical protective head gear when doing light gas welding. Dark green plastic window 8" x 11-1/2" snaps onto lightweight plastic adjustable headband. Permits full peripheral vision during work. Protects against radiation - flip up visor when not in service.
Headband - Model K P/N 12-05000 **\$9.00**
Visor P/N 8124D **\$4.90**
Complete Shield P/N 12-05100 **\$13.90**

HUNTSMAN ELECTRONIC WELDING HELMET

Call for prices and information on the new Huntsman Autoview Welding Filters which provide uncompromising eye protection.



WELDVIEW GOGGLE - For heavy duty work and full protection against radiation and impact in gas welding, cutting, burning and brazing. Soft opaque green mask. Can be worn over personal glasses. Glass cover plate and Filterweld plate supplied. Meets requirements of American National Stds. Inst. (ANSI) Standard Z87.1. P/N 12-04910 **\$11.90**

TIP CLEANER SET - 13 cleaners for #49 - #75 drill size orifices.
P/N N250 **\$9.20**

SINGLE STAGE REGULATORS

(1) H1710A-540 for Oxygen, 0-100 PSI P/N 12-19300 **\$88.00**
(1) H1721A-510 for Acetylene, 0-15 PSI P/N 12-19400 **\$86.00**



TORCH BODY - Designed to handle light duty welding and fabricating. Compact size provides easy handling even in confined areas. Needle valves located at front end for easy one-hand flame adjustment. Inlet connections 3/8"-24 right & left hand, fit "A" size hose nuts.
P/N AW1 **\$97.75**

Five Light Duty Welding Tips:

For Metal Thickness Up To
1/32"AW201 **\$27.70**
1/2"AW203 **\$27.60**
3/32"AW204 **\$26.00**
1/8"AW205 **\$27.60**

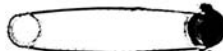

One Single Flint Lighter
P/N N113-A **\$3.60**
Box of Six Extra Flints for Lighter P/N N113-3

\$3.45
Twin Hose, 12-1/2 Ft. (3/16" I.D.) P/N RA921 **\$8.00**
One Pair American Optical Weldview Goggles P/N 91225 **\$10.95**

TO

WELDING EQUIPMENT - BLASTING SYSTEMS



TIP CLEANERS

Quality aluminum case with rustproof stainless steel wire. The long spiral cleans a large number of tip styles. A hardened steel file included in each case.
P/N 12-05180\$2.95



BULLDOG RED WELDING DAMAGE CONTROL CLOTH

This heavy duty red cloth is made from .015" thick fiberglass with a Hypercote finish. It resists abrasion and liquids, cuts without fraying, is electrically non-conductive and chemical resistant, and drapes easily. Protects persons, machinery and structures from sparks and splatter during welding. Wt: 13 oz/sq. yd. Furnished in 60" width.
P/N 12-19500\$14.90/lineal yd.



MAGNETIC UNI-JIGS

Magnetic holders for hands-free support in a variety of applications. Designed to last a life time. Each angle is screwed (not riveted) completely through the magnet to insure proper angles.

Small (supports up to 45 lbs.)P/N 12-05185\$7.95
Large(supports up to 80 lbs.)P/N 12-05186\$17.95



SILVER PENCILS

The best way to mark tubing. Will not corrode tubing and shows up well on greasy tubing. May be used to mark exhaust system without lead cracking
P/N 12-05190\$1.34



COW HIDE GLOVES

This is good import, not too stiff.
P/N 12-05155\$4.75



38" LEATHER WELDING APRON

Quick release buckle and cross straps make it very comfortable; it also has pockets.
P/N 12-05160\$17.95



FULL FACE SHIELD

Lightweight headgear, shield flips down over prescription glasses. Good over bifocals.
P/N 12-05175\$16.85



WA-GOGGLE

Gas welding goggle with adjustable headrest that pulls out and down. Permits easy use of eyeglasses. 2 x 4 lens.
P/N 12-05165\$31.40



OXY-ACETYLENE HOSE

3/16" hose that may be used with all welding outfits.

B-B Fitting:
12'P/N 12-05916\$9.40
25'P/N 12-05917\$16.50

A-B Fitting:
12'P/N 12-05918\$11.30
25'P/N 12-05919\$16.50



ECONOMY PORTABLE SAND BLASTING SYSTEM

A new portable blasting system for cleaning and surface preparation of metal, plastic, fiberglass or wood. Ideal for graffiti removal from brick or stone surfaces. Dee-Blast system consists of an abrasive hopper 20-1/2" high and 9-1/2" diameter molded PVC drum with tight fitting top to keep abrasive media clean. Hopper holds up to 65 lbs. of media. It has a 10 ft. long rubber hose, a full-length face shield and a trigger-operated blasting gun that completely mixes air and media to produce a uniform spray pattern.
P/N 130\$84.65

completely mixes air and media to produce a uniform spray pattern.

PORT-A-BLAST SANDBLASTER



The Port-A-Blast sand blast unit is the perfect tool for anyone who owns or flies an airplane. For removing paint and corrosion, cleaning spark plugs and even liquid blasting to clean your engine and parts. Its small compact design allows you to get into tight areas. Fill the container with an abrasive material and its ready to go to work. It will operate on as low as 60 psi. However, for best results, pressures of 100-500 psi are

recommended. The higher the pressure the faster the cutting will be. Port-A-Blast handles all types of abrasive, ranging from Silica Sand for average work to Nutshells for cleaning and polishing hard surfaces without scratching. For larger jobs you are also able to attach a siphon hose, and pull directly from a bucket. this is a versatile tool that every airplane enthusiast shouldn't be without. We now offer a kit for the enthusiast who's not quite sure which type of blast media the should use. The kit includes a Port-A-Blast gun and 4 media types: Glass Bead, Steel Shot, Nutshell, and Slag. We have also included a brief explanation of each media type and where it should be used.

Port-A-Blast gun.....P/N 12-00172\$59.95
Flexible siphon tubeP/N 12-00173\$10.95
Replacement Ceramic nozzle P/N 12-00493\$21.95

DELUXE PORTABLE PRESSURE BLAST SYSTEMS



Model 1000

These Portable Pressure Blasters are designed to make the most efficient use of your air and abrasive supply. These are not inexpensive siphon units. The entire tank is filled with air and sand under pressure. When the nozzle and valve is opened the sand/air mixture is released under tremendous pressure to quickly remove paint, rust, scale and other coatings. These units are 3-5 times faster to use than siphon units. All units arrive complete with air gauge, pressure vessel, sandblast hood, and sandblast hose. Simply fill with abrasive and attach to your air supply and you are ready to begin blasting. Order by Part no.

ABRASIVES - Black Beauty: Economical, fast cutting abrasive. For quick removal of paint and rust. 80# bag.
P/N 12-20740\$29.80



Model 400

Spec. Chart	Model 400	Model 1000
Operating Pressure	60-125 psi	60-125 psi
ASME Tank	No	Yes
Sandblast Hose	7 feet	10 feet
Abrasive Capacity	40-50 lb.	100-120 lb.
Nozzle Size	3/32"	1/8"
Part Number:	12-20725	12-20735
Price:	\$314.95	\$478.95

CENTURION TEAR-N-WEAR GOGGLES



Using the same patented technology as in professional racing, wearers have a clean, distortion-free viewing area again and again. The Centurion Tear-N-Wear system is easy to use. Once the surface is covered with dirt, paint or grime, the wearer simply tears off the top layer and keeps working. The Tear-N-Wear strips are made of 7 layers of laminated mylar film. Each layer is bonded together using a special adhesive. As a result, the layers do not diffuse light, which eliminates glare, light reflection and distortion often associated with viewing objects through multiple layers.
Centurion Tear-N-Wear Goggles.....P/N 12-00893\$14.95
Centurion Tear-N-Wear Replacement Strips.....P/N 12-00894\$11.85

TO

TOOLS — ROTATORS — TIRE BEAD BREAKERS

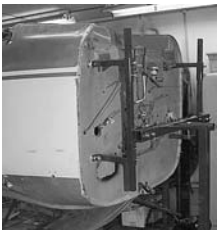

FUSELAGE ROTATOR

Defy the law of gravity when repairing, restoring, recovering or building a fuselage. You don't have to work with dirt, welding spatters, metal shavings, paint and dopes falling in your face or running down your sleeves! Do your welding, sheet metal work, fabric and painting from the best angle. Work in a comfortable position all the time for better workmanship! Locks in any position. It may be set at any angle. Attaches to the firewall at the engine mount holes and adjusts to fit any spacing. Assembles in just a few minutes. The fuselage is free to rotate a full 360 degrees and can be worked on in any position and locked in place. It adjusts for working height. Best of all, one person can easily spin the fuselage into the position they want to work in with complete control.

Forward unit (shown).....P/N 12-16780**\$423.95**
 Aft unit (not pictured).....P/N 12-16782**\$227.95**
 Complete set (both units)P/N 12-16784**\$577.00**



LANDING GEAR SAFETY STAND

The "Landing Gear Safety Stand" is a must! Anyone that has ever seen a plane slip off a jack knows! The stand slips on over the axle when ever the wheel is removed. Put the nut back on and the plane can't slip off the stand. It adjusts for height with a quick release pin. The wide, stable "H" base is made from heavy gauge square steel tubing for strength, safety and durability. The unique stand is finished in an attractive, bright red powder coat finish. LGSS-2, has a 12" x 12" base with adjustable axle height of 10"-15", and LGSS-3 has an 18" x 18" base with adjustable height of 14"-21.5".

LGSSP/N 12-16787**\$69.00**
 LGSS-2P/N 12-00255**\$64.00**
 LGSS-3P/N 12-00256**\$89.00**



STRUT SERVICE TOOL

The simple and clean way to service struts with hydraulic fluid. No more mess! Just remove the cap from the strut valve and screw on the SST hose fitting. This releases the strut pressure. Any fluid that escapes the strut is caught in the fluid bottle. *No mess at all and you didn't even have to remove the valve core!* Simple Filling! Just raise and lower the strut a few times and the fluid is sucked back into the strut without removing the valve core. Just unscrew the fitting from the strut and the strut is ready for its charge. It was clean, simple and quick! Just use one of our strut pumps and apply the charge. The "Strut Service Tool" comes with general strut servicing instructions. (Doesn't include hydraulic fluid.) P/N 12-16792**\$18.85**



PRO SERIES STRUT TOOL

Dual tank and dual check valve design. The Pro Series Strut Service Tool has all the great attributes of the original Strut Service Tool twice over. The longer service hose makes it easy to attach. Strut pressure, fluid and foam are captured in one tank. Clean, foam free fluid is drawn back in to the strut from the second tank. Simplicity cleanliness and less waste makes this tool a must-have. The strut valve core is not removed. Can also be used as a brake bleeder. P/N 12-00677**\$139.95**

WING ROTATOR



One person operation! That's right! One person can rotate virtually any wing safely and in complete control. So often when doing repairs, restorations or building a wing from scratch, the wing must be flipped over. The usual method involves two people and a couple of saw horses. With the "Wing Rotator",

one person can not only turn the wing over, but lock it in the vertical position as well as the horizontal position. This is a great convenience when doing dope and fabric work, painting or sheet metal repair. The tool adjusts for working height. Locks at any angle. Adjusts to fit virtually any wing. Assembles in a couple of minutes and ships in one 6"x6"x28" box. P/N 12-16785**\$258.95**



TIRE BEAD BREAKER

Once the tire and wheel have been removed from the airplane, the air is let out of the tire. The "TIRE BEAD BREAKER" is used to break the bead or bond between the tire and the wheel. The "TBB" let you safely break this bead almost without effort and without doing damage to the EXPENSIVE CAST WHEELS. The "Tire Bead Breaker" adjusts to fit tires as small as tailwheel tires and as large as those tires found on large, corporate cabin planes. P/N 12-16790 ..**\$139.95**

TIRE BEAD BREAKER



The universal design of this tire bead breaker accommodate tube type and tubeless tires. It is easily adjustable for a wide range of tire sizes up to as large as tires for Twin Beech and Aero Commanders. Features all steel construction. P/N 13-02360 ..**\$155.95**

ACCUGAGE PROFESSIONAL TIRE GAUGE



This very accurate bourdon tube tire gauge offers precision pressure control and a rugged steel case with rubber shock-absorbing cover. It comes complete with a 12" long flexible braided hose, a bleeder valve, and stop hand. It is easy to read the pressure on this 2" gauge with 1" psi markings and 60 lb. range. Excellent for use on aircraft tires as well as cars and trucks. P/N 13-00437**\$15.95**

AIR ARM TIRE FILLING ADAPTER



This adapter permits the easy air charging of tires inside of most light aircraft wheel pants. The Air Arm will couple to virtually all air dispensing connectors in the aircraft field. The Air Arm can be ordered with or without the gauge adapter head.

AirArm w/gauge adapt. head.....P/N 12-30180**\$36.80**



ANGLE COMMANDER

One person can install an engine using this tool. This changeable multi-point hoist provides nearly 80° of controlled angle. The user controls the entry by adjusting the balance point. Change from a 2-point to 3-point by adding one Commander Cross arm, or add 2 Cross Arms for a 4-point lift. Ideal for aircraft, automotive, equipment and manufacturing applications. Rugged, heavy-duty construction for long life, with 4 ton load, 8000 lbs. capacity.

Angle CommanderP/N 12-00160**\$199.00**
 Commander Cross ArmsP/N 12-00161**\$39.95**

TO

SCALES – JACKS

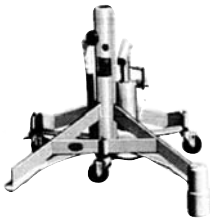

MEYERS HYDRAULICS AIRCRAFT JACKS

Meyers Hydraulics have been recognized as the industry standard for aircraft jacks for over 25 years. Professional mechanics rely on the AJS Jack Set for applications requiring heavy-duty lifting capacity, smooth maneuverability, and reliability. Refer to the Application Chart below for the components required for your aircraft, and then order from the price list accordingly.

APPLICATION CHART

Aircraft	Jacks	Tailstand	Legs	Tubes & Caps
Aero Commander	(2) A-6	(1) ATS	(2) AJL	(2) AT-4
Beech: Model 50, King Air, Queen Air	(2) A-6 (1) A-5	----	----	----
Beech: Bonanza, Debonair, Travelaire, Baron				
Mooney Piper: All except Navajo & Aerostar	(2) A-5	(1) ATS	----	----
Piper Navajo & Aerostar	(2) A-6	(1) ATS	----	---
Cessna: Cardinal RG	(2) A-6	(1) ATS	----	(2) AT-4 (2) ATC-8
Cessna: All high wings RGs except Cardinal	(2) A-6	(1) ATS	(2) AJL	(2) AT-4 (2) ATC-8
Cessna: 310, 320, 401, 402, 411, 414, 421	(2) A-5 (2) A-6	----	----	(2) AT-28
Navion	(2) A-5	(1) ATS	----	(2) AT-28

P/N	Description	Price	AJS	Height Ranges
12-21405	A-5 Jack	\$567.00	A-5	w/AT-1* = 22"/36"
12-21410	A-6 Jack	\$538.00	A-5	w/AT-28= 28"/42"
12-21415	ATS Tail Stand	\$177.95	A-5	w/AT-3 = 34"/58"
12-21435	AJL Leg	\$82.75	A-6	w/AT-2* = 34"/58"
12-21440	AT-1 Tube	\$42.20	A-6	w/AT-4 = 54"/78"
12-21445	AT-2 Tube	\$49.20	A-6	w/AJL Legs + 10"
12-21455	AT-3 Tube	\$50.75	ATC-4	Cap + 1 to 4
12-21460	AT-4 Tube	\$51.25	ATC-8	Cap = 1 tp 8"
12-21465	AT-28 Tube	\$37.60		
12-21470	ATC-4 Cap	\$56.75		
12-21475	ATC-8 Cap	\$62.75		

(* ATC Caps will not work on these tubes.)

AJS UNIVERSAL AIRCRAFT JACK SET

The AJS Universal Aircraft Jack Set from Meyer Hydraulics has served as the general aviation industry standard for over 25 years. Professional mechanics rely on the AJS Jack Set for applications requiring heavy duty lifting capacity, smooth maneuverability, and unquestioned reliability. The AJS Set lifts all retractable gear aircraft weighing up to 8000 lbs.

AJS System:

- | | |
|--|-----------------|
| 1. A-5 Jack w/ AT-3 Tube | 6. AT-3 tube |
| 2. A-5 Jack w/ AT-1 Tube | 7. AT-1 tube |
| 3. ATS Tallstand | 8. AT-4 caps |
| 4. A-6 Jack w/ AT-2 Tube | 9. AT-2 tube |
| 5. A-6 Jack w/ AT-4 Tube & AJL Leg Set | 10. AT-4 tube |
| | 11. AJL Leg Set |

P/N 12-21476.....\$2,395.00

AJS2 DELUXE JACK SET

Includes one complete AJS Jack system (describes above) plus one A-5 Jack with AT-1 tube, one AT-28 tube, and one ATC-4 cap. A very popular Jack system for general aviation maintenance.

P/N 12-001378\$64.25

RUGGLES AIRCRAFT SCALES



Ruggles Scales make it easy and affordable for you to compute weight and balance on your own aircraft any time and any place. They are small and easy to transport. With their drive up capability, there is no need to jack up each wheel to slide scales in place. Ruggles Scales use the principle of a fulcrum and a very long lever. So simple, the only tool you will need is a screwdriver for calibration. Sturdily constructed of cadmium plated steel and precision engineered for accuracy. Complete instructions are included with scales. Not certified. Capacity is 3600 lbs. (1200 lbs. per wheel). Scale can be set to either 2:1 or 4:1 ratio. Tricycle gear set includes 3 arms and 3 scales. Taildragger set includes 2 arms and 3 scales.

Tricycle gear Ruggles Scales setP/N 12-21400\$310.00
Taildragger Ruggles Scales setP/N 12-21450\$275.00

PRECISION AIRCRAFT SCALES FOR ACCURATE WEIGHT & BALANCE

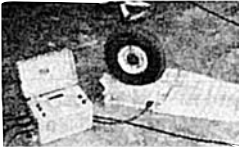

Simple, accurate weighing of aircraft, and other vehicles. Checks aircraft weight and balance after modifications or fitting of new accessories. Flight safety is improved by periodic weighing to verify weight and balance is within limits. Simply roll the aircraft up the ramps onto the scales or jack the wheels and slide the pads under tires. A single high performance strain gauge load cell is in each pad. Temperature compensation prevents zero shift or sensitivity changes. Weighing pads, indicator and cables are color coded for easy match up. LCD Channel Indicator is readable in direct sunlight, and displays each pad or total combination. Self powered rechargeable battery features 30 hour operation between recharging. Operates from 115VAC when charger is plugged in (220VAC optional). Features heavy duty cast construction, interchangeable pads, pounds/kilograms selector, certificate of conformance, and 1 year warranty. Pad size: 1000 and 2000 lb. pads 13"L x 14"W x 2-3/4"H. 5000 lb. pads and higher 17"L x 17 "w x 4 "h. All Road Runner Wheel Weigher sets include one 3 channel indicator, three colored cables, one 110V battery charger cable, three ramps, and six tie stops. Also includes a case.

Part No.	Capacity	Price
12-16711	2,500 lbs. per pad	\$4,353.00
12-16715	6,000 lbs. per pad	\$6,586.00
12-16721	10,000 lbs. per pad	\$6,585.00
12-16725	15,000 lbs. per pad	\$7,858.00

OPTIONS

Part No.	Description	Price EA.
12-16730	Extra cable, colored	\$160.00
12-16735	Extra ramps, small, set of 3	\$198.95
12-16740	Extra ramps, large, set of 3	\$439.95
12-16745	Extra tire stops (chocks)	\$42.50
12-16750	220V Battery Charger Cable for overseas	\$489.95

JACK PADS

Jack pads provide a cradle for the main landing gear legs. The cradle design securely holds the landing gear providing a safe jack point. The adjustable jack pad fits flat spring gear. The round gear jack pad fits the models listed below. • Save time when servicing tires, wheel bearings and brakes • Lift only the wheel instead of the whole aircraft • Eliminate the unsafe practice of stacking wood blocks under a bottle jack • All parts pack away neatly into a sturdy weather resistant toolbox • Made in USA

FLAT PIVOT POINT ADJUSTABLE JACK PAD



Built for steep and raked angle gear legs found on many tail draggers. This pad adjusts to the shifting geometry of the aircraft's landing gear while jacking. Use with 6 ton bottle jack. Fits: Cessna 120, 140, 150, 170, 172, 175, 180, 182, 185, 188, 190, 195, 205, 206, 336, 337. Also: Piper, Tomahawk, Beech Skipper, Champion, Bellanca and other similar spring steel landing gear.

P/N 12-00837\$64.25



Half round design cradles the gear. Pivots on a machined bottle jack extension. Use with Cessna C-172RG, 177RG, 182RG, 210, T210, P210, and similar landing gear.

P/N 12-00679\$64.25

Used to jack aircraft req. external, removable jack point pads like Cessna 300, 400, 500 Series

P/N 12-00683\$64.25

JACK EXTENSIONS



Much safer than stacking wood blocks under a bottle jack! Bottle Jack Extensions will fit any 1-1/4" O.D. ram • Typical 6 ton jack has a 1-1/4" O.D. ram • Extensions are machined and slide together for easy stacking • Use on aircraft with a jack point pin • Not the same extensions as found in the Aero Jack Kit • No special jack pad needed on tubular C-152, 172, 182 etc. Jack is not included.

1.5" extensionP/N 12-00156\$22.00
3" extension.....P/N 12-00157\$22.35
8" extension.....P/N 12-00158\$25.00

THE PLANE JACK



No other product on the market lifts the nose wheel as safe, fast, and easy. Don't let ANYONE put weights on the tail of your airplane again. This causes significant stress on the airframe. Stop this damage. There is a better way. **Features:** Fast, easy, guaranteed for life. • Eliminate dangerous stress on the tail of your airplane. •Lift the nose wheel fast and easy for service. •Recommended by A&P's as improved method for jacking up nose wheel. •To be used on all single engine Cessna aircraft with wing struts.

P/N 12-01371\$64.25

AIRCRAFT SPRUCE WEST
CORONA, CA • (877) 4-SPRUCE

591
Prices Subject to Change Without Notice

AIRCRAFT SPRUCE EAST
PEACHTREE CITY, GA • (877) 477-7823

TO

JACKS – DE-ICERS

AIRCRAFT GROUND DE-ICING SYSTEMS



Use this FAA approved, SAE Type I aircraft ground deicing fluid to remove frost, ice & snow from all metal & composite fixed-wing aircraft prior to flight. May be carried aboard your aircraft. Non-hazardous/Biodegradable. Best applied heated. Effective to -12°F. OAT. Handheld sprayers are designed specifically for aircraft deicing, and accept special 120V heaters to heat the fluid within the sprayer tank to 160°F.

Description	Part No.	Price
Ice-Off fluid (5 gal.)	12-21600	\$95.80
Handheld Sprayer (1 gal. Capacity)	12-21605	\$85.25
Handheld Sprayer (2 gal. capacity)	12-21610	\$96.00
Handheld Sprayer (3 gal. capacity)	12-00499	\$104.95
120V-1100 w/Heater (for 1gal. sprayer)	12-00501	\$342.20
120V-1400 w/Heater (for 2gal. sprayer)	12-00502	\$351.60

CESSNA LOW WING AIRCRAFT JACK



300 & 400 models except 337 & 400 C Model. Height range from 33" low to 53" high. 3 ton each jack. Furnished with wheels.

P/N 12-21570 **\$328.95**

HIGH WING AIRCRAFT JACK



For Piper Navajo, Twin Bonanza & most low wings. Now you only need one set of Jacks for high and low wing aircraft. Use with legs for high wing aircraft remove legs for low wing aircraft. 3 leg design, sits flat on uneven floor, clears gear doors. Welded steel construction "NOT" just bolted to a plate. Collapsed Ht. (Legs Removed): 25" • Fully Extended: 45" • Jack Cap.: 6000 lbs. ea. • Shipping Weight: 53 lbs. • Ram Diameter: 1-3/32"

With one set of legsP/N 12-21575 **\$328.95**
 Additional sets of legsper set **\$100.00**

AIRCRAFT JACKS

Constructed of welded square steel tubing. The three leg design clears close tolerance gear doors, such as Bonanzas and Barons. All models have machine jack point centering cap with casters, jack handle holder and positive locking jack point centering cap with casters, jack handle holder and positive locking collars. Oversize shipping charges apply.

Aircraft Jacks	Image	Part No.	Price
Piper and Mooney Jack and other light twins and singles Height 26"-45". Cylinder Capacity **6,000 lbs.		12-99115	\$284.95
Cessna 300 & 400 Jack Series. Same as the J-105 except height 27"-52". Cylinder capacity **16,000 lbs.		12-99120	\$336.95
FBO Heavy Duty Jack The most versatile jack on the market from low wing singles and twins to high wing retractables. Height "27"-95". Cylinder Capacity** 16,000 lbs		12-01370	\$424.00
Tail Stand 18"-35:	-	12-99130	\$131.95

JACK POINTS

Aircraft Jacks	Image	Part No.	Price
Adjustable Jack Points Fits Cessna 150, 172, 182, 188, Citabrias, Bellancas, & Grumman. Slide bar adjusts easily to a number of widths and infinite angles on aircraft with flex spring steel main gear legs, which allows use of one pad for several applications. Compatible with most jacks, including bottle and floor jacks. All steel construction and powder coated finish to resist scratches.		12-01373	\$99.40
Cessna Jack Points Spring Gear Type		12-01374	\$57.20
Mooney Jack Points		12-01375	\$26.35

PROP SLING, (BOGI-LIFT)



Now you won't have to jack up the whole aircraft to pack bearings, change a tire or service the nose strut. Using the prop sling is easy. Slide the wide lift straps over the prop blades. Next slip the opposite end of the straps over each end of the Bogi-Lift. Attach the Bogi-Lift to your engine hoist and lift the nose. Can be used with 2 and 3 blade props. It also works great for support when installing a prop.

P/N 12-16718 **\$89.00**

RV HI-JACK CRANKUP WHEEL LIFT SYSTEM



You can lift a 500 lb. wheel load by cranking it up with one hand. No blocks are required to hold the axle when taking the wheel off. The lift hook is located on the axle in back of the wheel. The wheel is now completely free to come off and return after repair. All tools are provided to loosen bolts on the brake and axle nut. Cotter pins are removed with pliers provided. New pins are supplied. Wheel can be separated from the tire, and the tube repaired. The tire patch kit is provided. All equipment is supplied for a flat tire repair with one person. No other hydraulic jacks or hoists are needed. All equipment is packaged in a custom canvas bag with a tie at the top. The canvas bag is shipped in a plastic cover bag, and all equipment is inside. The total weight is 7 lbs. This package is small, and can be easily stored in the baggage area. This product solves a major problem on RV aircraft for wheel removal.

P/N 12-00910 **\$233.95**

AERO JACK KIT



Complete system for jacking both flat and tubular gear aircraft. The Aero Jack kit is a combination of innovative tools packed in a handy toolbox. Designed by an A&P, the Aero Jack Kit includes, one jack pad for flat gear and one tubular gear a fixed jack point pad, a set of bottle jack extensions, and a special 6 ton hydraulic jack. They can be used together as well as independently. Both jack pads provide a cradle for the main landing gear legs. The adjustable jack pad fits flat spring gear, adjustable in width from 3" to 6-1/2". The tubular pad fits Cessna 177, 177RG, 172RG, 182RG, 210, T210, P210 and others with tubular round landing gear. The cradle design securely holds the landing gear proving a safe jack point

Service KitP/N 12-00254 **\$249.95**

AEROJACK FLAT GEAR KIT

Model 30-AJF • ADJ-F Flat Jack Pad for spring gear adjustable from 3" to 6-1/2" • Stackable Machined Jack Extensions • Fixed jack point jack pad. • 6 ton Hydraulic Jack • Toolbox holds everything secure. Use with Cessna C-120, 140, 150, 170, 172, 175, 180, 188, 182, 190, 195, 205, 206, 336, 337, flat gear 177RG, Piper Tomahawk, Beech Skipper, Champion, Bellanca, and similar landing gear.

P/N 12-00681 **\$209.00**

AEROJACK ROUND GEAR KIT

Model 30-AJR • ADJ-R Round Jack Pad for round or tubular gear listed. • Stackable Machined Jack Extensions. • Fixed jack point jack pad. • 6 ton Hydraulic Jack. • Toolbox holds everything secure. Use with Cessna C-172RG, 177RG, 182RG, 210, T210, P210, and similar landing gear.

P/N 12-00682 **\$209.00**

BOGERT JACK PAD



Built for steep and raked angle gear legs found on many tail draggers. This pad adjusts to the shifting geometry of the aircraft's landing gear while jacking. Use with 6 ton bottle jack. Fits: Cessna 120, 140, 150, 170, 172, 175, 180, 182, 185, 188, 190, 195, 205, 206, 336, 337. Also: Piper, Tomahawk, Beech Skipper, Champion, Bellanca and other similar spring steel landing gear.

P/N 12-00837 **\$77.00**

BOGERT TRIBAL JACK



Forget expensive wing jacks for simple projects! Reach for Bogerts 6-ton Tribal Aircraft Jack! Raise each wheel independently in seconds. Adjustable lifting height. Originally designed for Pipers, thus the name "Tribal Jack", it is also used on King Air, Muskateers, Debonairs, Sundowners, Mooneys and many more!

P/N 12-00838 **\$168.95**

BOGERT LIL' LIFTER



Low profile and lightweight, the Lil Lifter is perfect for small, lightweight aircraft. It requires only 2.5 inches clearance and can achieve a vertical height of 12 inches. Weighs only 7.5 pounds. Some aircraft that use this versatile jack include the Vans RV, Cirrus, Long-EZ and many more!

P/N 12-00839 **\$135.95**

JACK LIFT PAD



This Jack Lift Pad is quality made of alloy steel and is adaptable to all bottle type hydraulic jacks. The serrated vee design provides positive holding. It is easy to install and proves a great variety of applications.

P/N 12-30270 **\$38.40**

TO

SAFETY EQUIPMENT



HOBBYAIR RESPIRATOR

The Hobbyair Pro 1 is a fresh air breathing system specifically designed for the amateur painter which allows only fresh air to reach the user's lungs. It features a comfortable, lightweight facemask with beltline hook, simple snap together fittings, and is very affordable. Includes the pump unit with two stage, single speed, air bypass type motor, mask, belt and 40 foot delivery hose, fittings, filter, cord and case. The Buddy System Hobbyair is designed for two people and includes two 40 ft. delivery hoses. 1 yr warranty. Excellent for use in homebuilt aircraft construction and painting.

- Hobbyair Pro 1 (1/2 mask) 110VP/N 12-15850**\$395.95**
- Hobbyair Pro 1 (1/2 mask) 220VP/N 12-15860**\$436.95**
- Buddy System Hobbyair (110V).....P/N 12-15870**\$532.00**
- Hobbyair Pro (Full mask)P/N 12-15851**\$512.00**
- Hobbyair IIP/N HB02**\$455.95**

CITATION 4 HVLP SPRAYER/RESPIRATOR



Similar to, but much more powerful than their standard CITATION unit, this new sprayer will allow its' user to achieve 'show plane' quality results to a level never before possible with a turbine powered system. Do you have HVLP finish quality reservations? You can forget about them with this new system! The CITATION '4' offers a much higher PSI range without sacrificing the benefits of HVLP such as lower overspray, the elimination of moisture and high transfer efficiency. This is all accomplished with a more powerful, yet quieter and cooler running turbine blower. Like the standard CITATION, this new system, of course, offers the additional benefit of a built-in supplied-air respirator to assure breathing protection for its' user. P/N 12-00973**\$1,150.00**



PAINT SPRAY RESPIRATOR

Chemical-cartridge respirator for protection against organic vapors, paint, lacquer and enamel mist and dusts. Replaceable pre-filters and chemical cartridges. Approved by U.S. Bureau of Mines and the National Institute for Occupational Safety & Health (MESA/NIOSH Approval No. TC-95).

- #95110, RespiratorP/N 12-15700**\$35.00**
- #95111, Replacement Cartridges Set of Two.....**\$10.85**
- #95112, Replacement Pre-Filters Set of Two**\$2.95**
- #R185B, Clips for Pre-Filters Pkg. of 2**\$3.00**



MOLDEX SAFETY MASK

The Moldex #2200 respirators are extremely effective and comfortable to wear. The molded shell does not collapse in heat and humidity & flame retardants are added to decrease flammability. Facepiece is naturally contoured for a comfortable fit without pressure points. MSHA and NIOSH approved. P/N 12-16100.....**\$1.19/ea.**

40% Discount on Box of 20 Masks



#8500 NON-TOXIC PARTICLE MASK (3M)

Effective paper throw away masks. Give excellent filtration for nontoxic dusts, powders and spray particles. P/N 8500**\$0.34 Ea.**

10% Discount on 12



SAFETY SPECTACLES

These safety spectacles feature a contoured shape which offers unobstructed vision, excellent side protection and comfort fit bridge. Front color and temple color is black. Lens and sideshield color is clear. P/N 13-01310.....**\$8.85/ea.**



IMPACT GOGGLES

Protects eyes from flying objects. Can be worn over personal glasses. Perforated mask reduces fogging. Fully adjustable elastic headband. Clear polycarbonate lens, 050" thick, is easily removed for cleaning. Meets requirements of ANSI Z87.1

- GogglesP/N 91200**\$6.60**
- Replacement Lens, ClearP/N 91202**\$1.75**



FULL-SEAL PROTECTIVE GOGGLES

These goggles completely shield the face from chemical splash, flying particles and dust. They are ideal for use with epoxies and paints and are included in our Safe-T-Plus Kits. Self-ventilating for comfortable wear. P/N 11-00317**\$9.60/ea.**



SAFETY FACE SHIELDS

Provides protection for the face and neck against chemical splash and flying particles. Window 9" x 14". Unit adjusts easily to sizes 6 - 8-1/4.

- FaceshieldP/N 90029**\$18.60**
- Replace. Window, Clear...P/N 90030**\$6.20**



HEARING PROTECTOR

This 3-position ear muff offers protection from high noise levels. Lightweight comfort, effective design combine to provide high performance attenuation. Can be worn over or behind head, under chin.

- P/N 97030**\$14.60**



PELTOR PERSONAL HEARING PROTECTOR

Peltor Personal Hearing Protectors Provide maximum attenuation in severe noise environments such as jet engines, riveting, and industrial high noise areas. Features include soft, broad ear cushions and softly padded head band. Combined liquid and foam filled ear seals give good sealing and low surface pressure.

- Model H7AP/N 12-16110**\$12.95**



HEARING PROTECTOR ANTI-NOISE MUFF

Lightweight comfortable headset provides noise reduction of 20 db or better. NPR-21 over the head, NRR-20 behind the head or under the chin. Meets OSHA requirements. Foam padded adjustable headband fits all sizes.

- P/N 9703.....**\$110.30**



CABOT HEARING PROTECTORS

The Cabot hearing protectors are lightweight and comfortable, allows commands to be heard, liquid/foam ear cushions, and padded, adjustable headband.

- P/N 12-01172..... **\$64.75**



DAVID CLARK DELUXE HEARING PROTECTOR

The David Clark Deluxe Model Hearing Protector provides maximum noise attenuation and optimum comfort. Features urethane covered ear seals, soft foam cushioned headband, military quality materials, finish and workmanship. P/N 11-09205.....**\$35.50**



PELTOR WORKTUNES

Worktunes is a self-contained AM/FM noise attenuating headset (NRR 25db) which provides hearing protection combined with an AM/FM radio. Features include a wide, soft padded headband, flexible antenna, automatic soft switch from stereo to mono for areas with weak signals, quick & easy tuning and volume adjustments, and wide, soft cushions for low pressure, excellent sealing, and added comfort.

- P/N 11-01589**\$64.75**



PELTOR WORKTUNES

When workers lift their ear muffs, they lower their protection. Now Peltor puts safe listening at their fingertips. Just push the button on the PTL muff and speech and sounds "outside" the muff cup can be heard "inside" clearly and safely. After 30 seconds, the muff automatically returns to its full protection with a NRR of up to 26 dB. Listen again? Just push again. That simple. GREAT for race car crews and ground crews at airports.

- Over-the-head Ear Muff P/N 12-00895.....**\$64.75**
- Cap Attached Ear Muff P/N 12-00896..... **\$34.25**
- Hygiene Kit P/N 12-00897..... **\$6.85**